



Standard Specification and Test Method for Rear-Mounted Bicycle Child Carriers¹

This standard is issued under the fixed designation F1625; the number immediately following the designation indicates the year of original adoption or, in the case of revision, the year of last revision. A number in parentheses indicates the year of last reapproval. A superscript epsilon (ϵ) indicates an editorial change since the last revision or reapproval.

1. Scope

1.1 This specification covers child carriers that mount to the rear of bicycles in order to transport children or accessory loads with a maximum weight of 18 kg (40 lb). This specification does not apply to child carriers that mount in front of the handlebars, or to the top tube, head tube, or behind the handlebars in front of the rider.

NOTE 1—In the instructions, the manufacturer must warn the rider that a load added to the bicycle will lessen the stability and alter the riding characteristics of the bicycle. This complication is particularly important when riding with children who are near the high end of the weight range.

1.2 The following safety hazards caveat pertains only to the test method portions, Sections 5, 6, and 7, of this specification: *This standard does not purport to address all of the safety concerns, if any, associated with its use. It is the responsibility of the user of this standard to establish appropriate safety and health practices and determine the applicability of regulatory limitations prior to use.*

2. Referenced Documents

2.1 ASTM Standards:²

B117 Practice for Operating Salt Spray (Fog) Apparatus

2.2 ISO Standards:

ISO/TC149/SC1 N368, Luggage Carriers for Bicycles³

ISO/TC149/SC1 N369, Child Seats for Bicycles, Concepts, Safety Requirements and Testing³

2.3 Government Standards:

Title 16, Code of Federal Regulations, Part 1500.44, Flammability⁴

Title 16, Code of Federal Regulations, Part 1500.48, Sharp Points⁴

¹ This specification is under the jurisdiction of ASTM Committee F08 on Sports Equipment, Playing Surfaces, and Facilities and is the direct responsibility of Subcommittee F08.10 on Bicycles.

Current edition approved April 1, 2008. Published May 2008. Originally approved in 1995. Last previous edition approved in 2000 as F1625 – 00. DOI: 10.1520/F1625-00R08.

² For referenced ASTM standards, visit the ASTM website, www.astm.org, or contact ASTM Customer Service at service@astm.org. For *Annual Book of ASTM Standards* volume information, refer to the standard's Document Summary page on the ASTM website.

³ Available from American National Standards Institute (ANSI), 25 W. 43rd St., 4th Floor, New York, NY 10036, http://www.ansi.org.

⁴ Available from Superintendent of Documents, U.S. Government Printing Office, Washington, DC 20402.

Title 16, Code of Federal Regulations, Part 1500.49, Sharp Edges⁴

16 CFR 1501, Small Parts⁴

16 CFR 1303, Lead in Coatings⁴

3. Terminology

3.1 Definition:

3.1.1 *bicycle child carrier*—a seating device, the shape of which is adapted to the seated position of a child and mounts to the rear of the bicycle, which keeps the child in a comfortable position during the ride.

4. Requirements

4.1 *General*—Child carriers shall be designed and manufactured in such a way that components with which the child or rider come into contact do not cause injuries during normal use, or when used in accordance with the manufacturer's instructions. Surfaces must be free from burrs, sharp edges, and points; if such are present they must be covered by protective coverings. No openings with which the child's hands can come in contact shall have dimensions larger than 6 mm (0.236 in.) but also smaller than 13 mm (0.512 in.), that is, holes with dimensions between 0.236 and 0.512 in. (6 and 13 mm) are forbidden. Child carriers must be equipped with a rear reflector. The manufacturer must warn the rider that a load added to the bicycle will lessen the stability and alter the riding characteristics of the bicycle.

4.2 Structure:

4.2.1 *Assembly*—When assembled in accordance with the instructions provided by the manufacturer, the seat components must be firmly joined and fixed.

4.2.2 *Equipment*—Child carriers shall be equipped with the following equipment:

4.2.2.1 Footrests,

4.2.2.2 Backrest,

4.2.2.3 Armrests (that may be extensions of the sides of the seat surface),

4.2.2.4 Protective devices that prevent contact of hands and feet with moving or movable components of the bicycle which could cause injury, and

4.2.2.5 Belt or other capturing devices designed to restrain the child from standing in or leaving the carrier. Buckles, if used, must be difficult for the child passenger to open.

4.2.3 *Attachment*—The attachment process for connecting the seat portion of the carrier either to dedicated mounting hardware or to a luggage carrier, and attachment of the mounting hardware or the luggage carrier to the bicycle frame, shall be of a simple and secure procedure. If tools are required for mounting, mounting must be accomplished with common household tools, and must offer no reasonable opportunity of incorrect mounting.

4.2.4 *Test Criteria*—After testing in accordance with Sections 5 and 6 of this specification the child carrier shall show no visible signs of fracture, nor any deformation or displacement that would impair the function of the child carrier or the bicycle, as defined by the allowable amounts set forth in Sections 5 and 6.

4.3 *Security of Seat Assembled to Bicycle:*

4.3.1 If the means of attachment of the carrier to the bicycle is within easy reach of the child, and also is of a type that the child may be able to loosen, then there shall be a secondary device to restrict movement of the carrier, either by providing an additional and independent attachment or by ensuring that loosening the primary attachment will not fully release the connection.

4.3.2 Child carriers that do not attach directly to the bicycle seat tube, such as rack-mounting models, shall have an additional attachment device connecting the seat portion either to a frame tube or to the saddle pillar, with sufficient strength to limit rearward movement of the seat.

4.4 *Dimensions:*

4.4.1 Dimensions of the interior of the carrier seating area shall be adequate for the seated child at the upper range of the weight limitation.

4.4.2 The backrest must have a minimum height of 350 mm (13.8 in.).

4.4.3 The armrests must be high enough to keep the child stable in lateral directions.

4.5 *Materials:*

4.5.1 Plastics or other synthetic materials, if used, shall be stabilized against ultraviolet radiation and resistant to ozone.

4.5.2 The carrier shall be protected against corrosion and tested in accordance with salt spray test defined in Practice B117, for a period of 96 h. Tested components shall show no visible evidence of corrosion or deterioration which could jeopardize structural integrity of the entire assembly. The tested unit shall continue to operate in accordance with the manufacturer’s written instructions.

5. Environmental Temperature Tests

5.1 *General*—Perform the tests in this section on all carriers to determine whether there are any adverse affects on the strength and function of the carrier under conditioned environments.

5.1.1 Conduct these environmental temperature tests prior to the dynamic load tests that follow.

5.2 *Resistance to High Temperatures:*

5.2.1 Store the carrier for at least 4 h, but not more than 24 h at a temperature of $50 \pm 3^\circ\text{C}$ ($122 \pm 5^\circ\text{F}$).

5.2.2 Examine the carrier for damage or distortion that could affect the safety or function of the carrier.

5.2.3 Damage or distortion that could affect the safety or function of the carrier constitutes failure of the test.

5.3 *High-Temperature Drop Test:*

5.3.1 Store the carrier for at least 4 h, but not more than 24 h, at a temperature of $50 \pm 3^\circ\text{C}$ ($122 \pm 5^\circ\text{F}$).

5.3.2 Remove the carrier from the hot environment and mount it on the test fixture depicted in Fig. 1 that holds the lowest point of the underside of the seating area of the carrier shell at a height of 1.00 ± 0.01 m (39.37 ± 0.39 in.) above a concrete floor. The bottom of the fixture has a pivoting device that allows the fixture to rotate until it contacts the floor. The mass of the drop arm of the fixture is $11 + 0.5 - 0$ kg ($24 + 1.0 - 0$ lb). Within 1 min after removal from the conditioned environment, release the carrier under gravity from rest to one side or the other onto a flat concrete surface, as if the bicycle to which it was mounted fell over.

5.3.3 Examine the carrier for damage or distortion that could affect the safety or function of the carrier.

5.3.4 Damage or distortion that could affect the safety or function of the carrier constitutes failure of the test.

5.4 *Low-Temperature Resistance:*

5.4.1 Store the carrier for at least 4 h, but not more than 24 h, at a temperature of $-7 \pm 3^\circ\text{C}$ ($20 \pm 5^\circ\text{F}$).

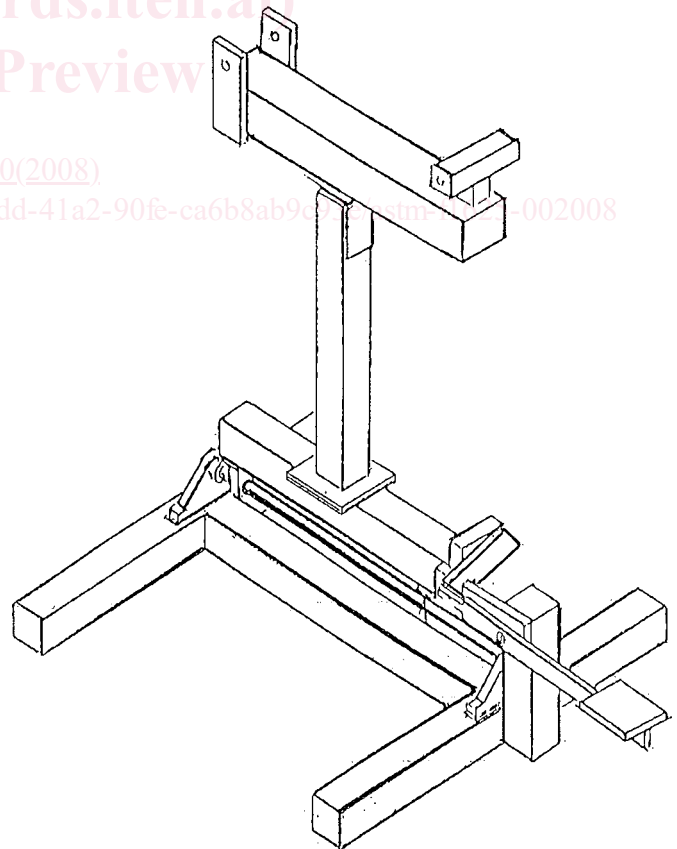

NOTE 1—Figures are intended only to indicate one possible configuration for test fixtures and are not intended to be adequate for fabrication.

FIG. 1 Child Carrier Drop Test Fixture