



Designation: F2523–05 Designation: F 2523 – 07^{€1}

Standard Practice for Blowout Resistance of Room-Temperature Vulcanized Elastomers¹

This standard is issued under the fixed designation F 2523; the number immediately following the designation indicates the year of original adoption or, in the case of revision, the year of last revision. A number in parentheses indicates the year of last reapproval. A superscript epsilon (ϵ) indicates an editorial change since the last revision or reapproval.

^{€1} NOTE—Added research report footnote to Section 13 editorially in May 2008.

1. Scope

1.1 This practice provides a means to determine the blowout resistance of a room-temperature vulcanized elastomer system (RTV) using a standard fixture.

1.2 The values stated in SI units are to be regarded as standard. No other units of measurement are included in this standard.

1.3 *This standard does not purport to address all of the safety concerns, if any, associated with its use. It is the responsibility of the user of this standard to establish appropriate safety and health practices and determine the applicability of regulatory limitations prior to use.*

2. Referenced Documents

2.1 *ASTM Standards:*²

D 907 Terminology of Adhesives

D 1566 Terminology Relating to Rubber

F 2468 Classification for Specifying Silicone Adhesives and Sealants for Transportation Applications

2.2 *SAE Standard:*

SAE J1199 Mechanical and Material Requirements for Metric Externally Threaded Steel Fasteners³

3. Terminology

3.1 *Definitions*—Some terms in this practice are defined in Terminologies D 907 and D 1566.

3.2 *Definitions of Terms Specific to This Standard:*

3.2.1 *blowout, n*—disruption of the uncured RTV integrity in a joint from system pressurization resulting in sudden loss of pressure.

3.2.2 *T-joint, n*—interface created in a sealing surface where three structural components meet.

3.2.2.1 *Discussion*—This interface may exist as a small gap requiring a material such as room-temperature vulcanized elastomer (RTV) to seal.

3.3 *Acronym:*

3.3.1 *RTV*—room-temperature vulcanized elastomer

4. Summary of Practice

4.1 Condensation cures RTVs as a one-component system cure when exposed to moisture in the ambient air or as two-component systems when those components are mixed together. RTVs are often used to seal joints where three flanges meet (T joints) such as an automotive engine's front cover, engine block, and oil pan. Because of machining and assembly tolerance variations, these T joints may have a slight misalignment or gap. We also find gaps in the half-round area of the oil pan to block and in the valley between the intake manifold and block on certain V-engines as a result of manufacturing tolerances. The RTV is used to seal in fluids. In some assembly line applications, soon after the RTV is applied and the flanges fastened together, the system is subjected to an air decay test at a designated pressure. This test is used to determine an RTV's capability to withstand loss of integrity at this designated pressure.

4.2 When using this practice, one must first determine the maximum gap based on stack tolerances of the system. A two-piece

¹ This practice is under the jurisdiction of ASTM Committee F03 on Gaskets and is the direct responsibility of Subcommittee F03.70 on Formed in Place Gaskets. Current edition approved Oct. 1, 2005. Published November 2005.

Current edition approved Oct. 1, 2007. Published November 2007. Originally approved in 2005. Last previous edition approved in 2005 as F 2523 – 05.

² For referenced ASTM standards, visit the ASTM website, www.astm.org, or contact ASTM Customer Service at service@astm.org. For *Annual Book of ASTM Standards* volume information, refer to the standard's Document Summary page on the ASTM website.

³ Available from Society of Automotive Engineers (SAE), 400 Commonwealth Dr., Warrendale, PA 15096-0001.

round fixture uses the top portion to mirror the system gap (default gap is 1 mm), while the bottom half provides the mating flange and the connection for the pressure input. The gap is machined into the top half of the fixture in a “pie slice” 60° angle. A continuous bead of RTV is applied to the entire bottom portion of the fixture, the top half is carefully attached, and the fixture is pressurized to the prescribed limits and held for a specified time period. If the RTV is not capable of sealing at the pressure applied, a sudden loss of pressure will occur.

5. Significance and Use

5.1 This practice may be used to determine the viability of an RTV sealant to withstand pressure leak testing before cure at maximum gap conditions of a system. This practice may be used to indicate an RTV’s acceptability to undergo an assembly line leak check without ~~being disruptive causing a leak path due to the sealant integrity.~~ material blow out.

6. Apparatus ⁴

- 6.1 ~~Fixture—Steel, see Fixture—Aluminum, see Fig. 1.~~
- 6.1.1 ~~Steel~~ 6.1.1 Aluminum casting, forging, or bar stock with a ~~100~~60 Brinell hardness, minimum.
- 6.1.2 Surface finish shall be in the range of 0.7 to 3.2 μm *Ra*.
- 6.1.3 ~~Top half of fixture shall have a machined cutout to the desired gap depth per~~
- 6.1.3 Top half of fixture shall have a machined cutout to the desired gap depth (1.0 \pm 0.025 mm default gap), per Fig. 1:
- 6.1.4 ~~Four nut, bolt, and washer sets per SAE J1199. The gap and flange width are critical dimensions and should be controlled to a tight tolerance (\pm 2.5 % is recommended). All other dimensions are allowed \pm 10 %.~~
- 6.1.4 Four nut, bolt, and washer sets per SAE J1199 (4.8 hex head) or equivalent, M10 \times 1.5 \times 50.
- 6.2 ~~Fixture—Aluminum, see Fig. 2.~~
- 6.2.1 Aluminum casting, forging, or bar stock with 60 Brinell hardness, minimum.
- 6.2.2 Surface finish shall be in the range of 0.7 to 3.2 μm *Ra*.
- 6.2.3 ~~Top half of fixture shall have a machined cutout to the desired gap depth, per Fig. 2.~~
- 6.2.4 Four nut, bolt, and washer sets per SAE J1199 (4.8 hex head) or equivalent, M10 \times 1.5 \times 50.
- 6.3 ~~Air supply and regulator.~~
- 6.4 ~~Polyethylene tubing (or equivalent), polytetrafluoroethylene (PTFE) pipe tape, plastic, or brass tube fittings.~~
- 6.5 ~~Inline pressure gage or equivalent, 0 to 138 kPa, accurate to \pm 0.7 kPa.~~
- 6.6 ~~Timing device with 1-s increments.~~
- 6.7 ~~Measuring device, capable of measuring an adhesive bead height of 2 mm.~~
- 6.8 ~~Environmentally controlled room (temperature, humidity monitoring, and control).~~
- 6.2 Air supply and regulator.
- 6.3 Polyethylene tubing (or equivalent), polytetrafluoroethylene (PTFE) pipe tape, plastic, or brass tube fittings.
- 6.4 Inline pressure gage or equivalent, 0 to 138 kPa, accurate to \pm 0.7 kPa.
- 6.5 Timing device with 1-s increments.
- 6.6 Measuring device, capable of measuring an adhesive bead height of 2 mm.
- 6.7 Environmentally controlled room (temperature, humidity monitoring, and control).

7. Reagents and Materials

- 7.1 ~~Cleaning Solvent—Isopropyl alcohol.~~ Appropriate cleaning solvent as specified by RTV manufacturer.
- 7.2 Clean, lint-free cloth.

8. Conditioning

8.1 Sample containers shall be allowed to equilibrate to 21 to 25°C. Time required may vary depending on the size of container and previous storage conditions.

9. Initial Step

9.1 Connect air supply to regulator and to pressure gage using polyethylene tubing. Plastic or brass press fit fittings may be used for the connection points, depending on the adaptor connection on the three components. Fittings threads shall have pipe sealant applied before installing into fixtures.

9.2 Connect tube to bottom fixture with a brass fitting containing pipe sealant applied around threads.

9.3 Block off open hole of fixture with a properly secured rubber stopper or compress a soft silicone plaque against the hole. Check for leaks at the various connection points by spraying a dilute liquid soap and water solution⁵ while looking for air bubbles.

9.4 Test environment shall be set at 21 to ~~25°C;~~ 25°C and 40 \pm 10 % relative humidity.

⁴ The sole source of supply of the blowout fixtures in both materials known to the committee at this time is Kovil Manufacturing, 925 Sherman Ave., Hamden, CT 06514. If you are aware of alternative suppliers, please provide this information to ASTM International Headquarters. Your comments will receive careful consideration at a meeting of the responsible technical committee, which you may attend.

⁵ Commercially available products exist from a wide variety of distributors.

Units, mm

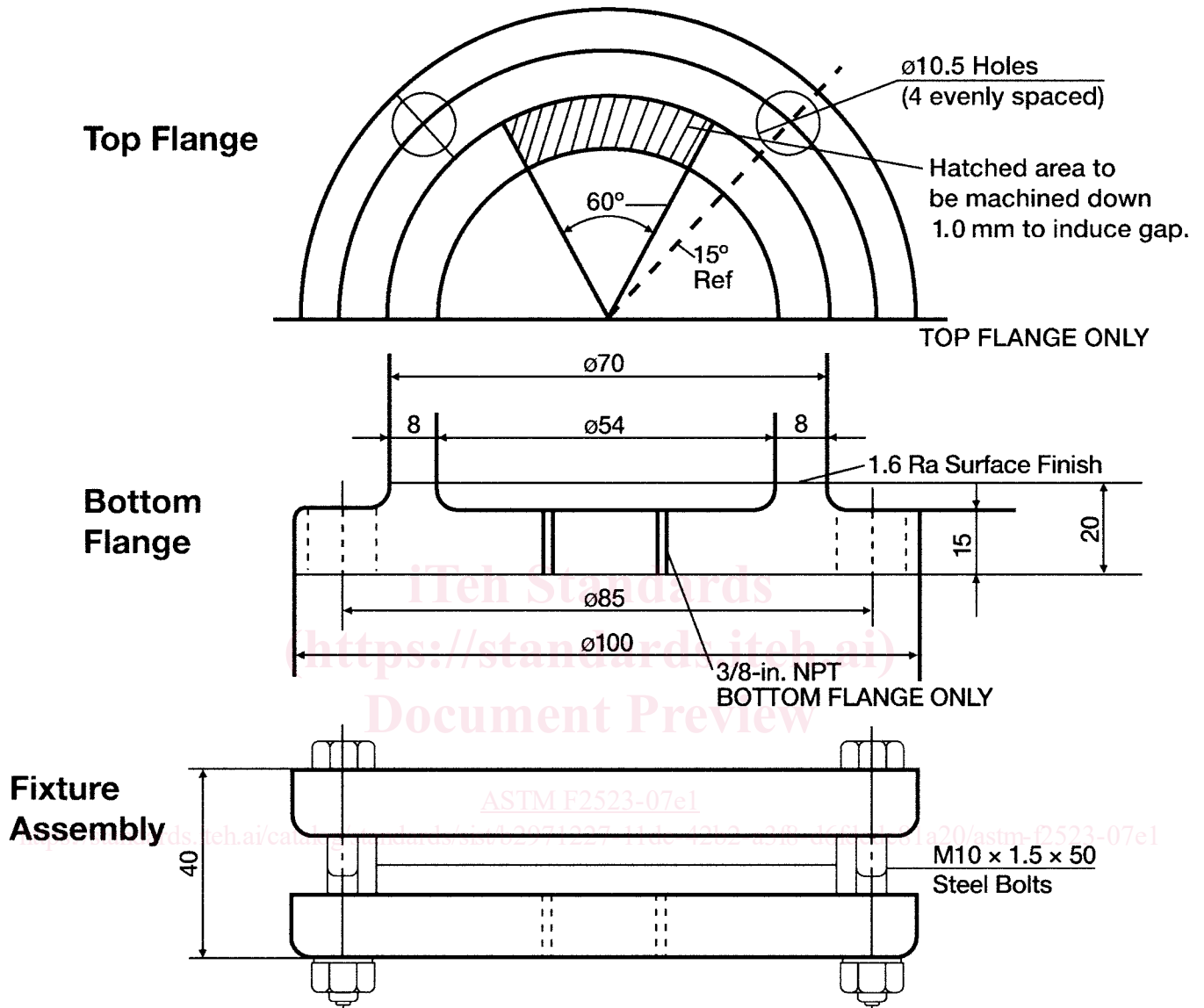

Top and bottom flange are identical except for 1.0-mm clearance and 3/8-in. NPT hole.

NOTE—Torque sequence shall be “crisscross” pattern.

FIG.-2 1 Aluminum Blowout Fixtures

10. Procedure

- 10.1 Choose a fixture with the desired machined gap.
- 10.1 Use either the default gap of 1 mm or choose a fixture with the desired machined gap.
- 10.2 Make sure all traces of cured or uncured RTV from previous test have been removed.
- 10.3 Following the initial setup instructions in Section 9, verify the system is free of leaks.
- 10.4 Method A—Time to Blowout at a Specified Pressure:
 - 10.4.1 Preset pressure regulator to the applicable test pressure.

10.4.2 Open exhaust valve to prevent any pretest internal pressure and close inlet ball valve.

~~10.4.3 Apply a continuous 2-mm bead on the flange of the bottom fixture.~~

10.4.3 Apply a continuous 4-mm bead (based on default gap, user will have to determine proper bead size for alternate gaps) on the flange of the bottom fixture.

10.4.4 Apply the top half of the fixture, taking care not to move the fixture horizontally.

10.4.5 Tighten bolts to ~~2.8~~1.0 kg·m \pm 10 %.

10.4.6 Close exhaust valve.

10.4.7 Immediately after assembly (within 2 min of RTV application) open ball valve to pressurize the system quickly to the preset pressure.

10.4.8 Start the timer and record the time in seconds at which the sudden loss of pressure occurs. If no loss of pressure occurs after 1 min, report it as “>60 s.”

10.4.9 Disassemble and clean the fixture thoroughly, removing all traces of RTV.

10.4.10 Repeat Steps 10.4.1 to 10.4.9 a second time.

10.4.11 If the second result is within \pm 10 % of the first result, report the average blowout time to the nearest second.

10.4.12 If the second result is in excess of \pm 10 % of the first, repeat until a consistent value is obtained.

10.5 *Method B—Maximum Blowout Pressure Determination:*

10.5.1 Method B shall be done at or near maximum application/flow rate of the sealant.

10.5.2 Open exhaust valve to prevent any pretest internal pressure and close inlet ball valve.

~~10.5.3 Apply a continuous 2-mm bead on the flange of the bottom fixture.~~

10.5.3 Apply a continuous 4-mm bead (based on default gap, user will have to determine proper bead size for alternate gaps) on the flange of the bottom fixture.

10.5.4 Apply the top half of the fixture taking care not to move the fixture horizontally.

10.5.5 Tighten bolts to ~~2.8~~1.0 kg·m \pm 10 %.

10.5.6 Close exhaust valve.

~~10.5.7 Immediately after assembly (within 2 min of RTV application), open the ball valve and start increasing the pressure by 6.9 kPa every 5 s until the initial pressure 20.7 kPa is reached.~~

~~10.5.8 Start the timer. If no loss of pressure occurs after 1 min, increase pressure by 13.8 kPa. Start the timer. Repeat this process until failure occurs and record this value.~~

~~10.5.9~~

10.5.7 Screen for approximate blow out pressure by opening the ball valve immediately after assembly (within 2 min of RTV application), so as to increase the pressure by 6.9 kPa every 10 s until blow out occurs. Subsequent iterations to determine blow out pressure may start 6.9 kPa below this screening pressure. If this screen pressure is at or below 20.7 kPa, the iterations shall use 3.45 kPa increments in this method; otherwise the increments shall be 6.9 kPa.

10.5.8 Immediately after assembly (within 2 min of RTV application), open the ball valve and start incrementally increasing the pressure every 5 s until the initial pressure of the screening pressure minus 6.89 kPa is reached.

10.5.9 Start the timer. If no loss of pressure occurs after 1 min, incrementally increase the pressure and start the timer. Repeat this process until failure occurs and record this value.

10.5.10 Disassemble and clean the fixture thoroughly, removing all traces of RTV.

~~10.5.10 Repeat Steps~~

10.5.11 Repeat the steps in 10.5.1 through 10.5.10, using the value obtained in 10.5.9. If this again results in a failure, clean the fixture and repeat the process using the value obtained in ~~10.5.8~~10.5.9 minus 6.9 kPa.

10.5.12 If failure occurs, repeat the process of cleaning and applying fresh RTV and testing, each time reducing the pressure until a “pass” occurs, then record this pressure.

10.5.13 Repeat the test a second time at this pressure to verify a “pass.” Report this value as the maximum blowout pressure.

11. Potential Failure Modes of Test Procedure

11.1 Inconsistent results in the procedure may be due to several reasons and shall be reviewed. Some of these may be:

~~11.1.1 Inconsistent RTV bead applied.~~

~~11.1.2 Misplacement of bead.~~

~~11.1.3 Air entrapment in RTV bead.~~

~~11.1.4 Improper gap.~~

~~11.1.5 Improper torque sequence or setting.~~

~~11.1.6 Contamination by improperly cleaned fixture.~~

~~11.1.7 Faulty pressure regulator or pressure measurement device or both.~~

~~11.1.8 Air leaks within the system, some of which can vary via fixture handling and movement.~~

11.1.1 Inconsistent RTV bead applied. RTV should be applied in an amount sufficient to fill the gap when the fixture is assembled and bolts torqued. Insufficient RTV will result in voids within the fixture gap. These voids will result in premature failure when running Method A, and possible lower pressure values when running Method B. Excessive RTV applied in the fixture gap will result in an internal and external dam of RTV that will resist movement of air by the applied pressure. This can result in