



Designation: ~~E299-97 (Reapproved 2002)~~ Designation: E 299 – 08

Standard Test Method for Trace Amounts of Peroxides In Organic Solvents¹

This standard is issued under the fixed designation E 299; the number immediately following the designation indicates the year of original adoption or, in the case of revision, the year of last revision. A number in parentheses indicates the year of last reapproval. A superscript epsilon (ϵ) indicates an editorial change since the last revision or reapproval.

1. Scope*

1.1 This test method^{2,3} covers organic solvents containing active oxygen in the range from 5 to 80 $\mu\text{g/g}$ (ppm) or higher. By using a special reaction-absorption cell, the test method can be extended to cover the range from 0 to 5 ppm. The test method can be used to determine numerous peroxide classes of varying reactivity such as hydroperoxides, diacyl peroxides, diaroyl peroxides, preesters, and ketone peroxides. The stable di-*tert*-alkyl peroxides do not react under the conditions of analysis.

1.2 Solvents that can be analyzed successfully include saturated and aromatic hydrocarbons, alcohols, ethers, ketones, and esters. In addition, the test method is applicable to olefinic solvents and to certain compounds that contain α , β , and conjugated unsaturation. Solid samples that are soluble in the acetic acid-chloroform solvent also can be analyzed.

~~1.3~~

1.3 The values stated in SI units are to be regarded as standard. The values given in parentheses are for information only.

1.4 This standard does not purport to address the safety concerns, if any, associated with its use. It is the responsibility of the user of this standard to establish appropriate safety and health practices and determine the applicability of regulatory limitations prior to use.

1.4⁵ Review the current Material Safety Data Sheets (MSDS) for detailed information concerning toxicity, first aid practices, and safety precautions.

2. Referenced Documents

2.1 *ASTM Standards:*⁴

D 1193 Specification for Reagent Water

E 180 Practice for Determining the Precision of ASTM Methods for Analysis and Testing of Industrial and Specialty Chemicals

3. Summary of Test Method

3.1 A sample is dissolved in a mixture of acetic acid and chloroform. The solution is deaerated and potassium iodide reagent solution is added. The mixture is allowed to react in the dark for 1 h, thereby releasing an equivalent amount of iodine. The absorbance of the solution is measured at 470 nm and the amount of active oxygen present in the sample is determined by reference to a calibration curve prepared from iodine.

3.2 For samples containing 0 to 5 $\mu\text{g/g}$ (ppm) active oxygen, a special reaction-absorption cell is employed. The sample is de-aerated and the reaction is carried out within the cell. Absorbance measurements are made at 410 nm to increase the sensitivity.

4. Significance and Use

4.1 Dilute solutions of peroxides in various organic solvents frequently are used as catalysts or reaction initiators. Peroxides also can be formed through autoxidation in certain classes of compounds including ethers, acetals, dienes, and alkylaromatic hydrocarbons and present a potential safety hazard. This test method provides a procedure for determining the peroxide or active oxygen level.

5. Interferences

5.1 Oxidizing or reducing substances present in the sample will interfere. Colored solutions can be analyzed if an absorbance correction is made.

¹ This test method is under the jurisdiction of ASTM Committee E15 on Industrial and Specialty Chemicals and is the direct responsibility of Subcommittee E15.01 on General Standards.

Current edition approved Dec. 10, 2002; April 1, 2008. Published May 2003-2008. Originally approved in 1966. Last previous edition approved in 1997-2002 as E 299 – 97(2002).

² Banerjee, D. K., and Budke, C. C., *Analytical Chemistry*, ANCHAM, Vol 36, 1964, pp. 792–796.

³ Banerjee, D. K., and Budke, C. C., *Analytical Chemistry*, ANCHAM, Vol 36, 1964, pp. 2367–2368.

⁴ Annual Book of ASTM Standards, Vol 11.01.

⁵ For referenced ASTM standards, visit the ASTM website, www.astm.org, or contact ASTM Customer Service at service@astm.org. For *Annual Book of ASTM Standards* volume information, refer to the standard's Document Summary page on the ASTM website.

*A Summary of Changes section appears at the end of this standard.

6. Apparatus

6.1 *Spectrophotometer*—Beckman Model DU or equivalent with matched 1-cm cells.

6.2 *Special Reaction-Absorption Cell* (Fig. 1)—When this cell is used, the regular Beckman cell carriage shall be replaced with the attachment provided for measuring the absorbance in test tubes.

7. Reagents

7.1 *Purity of Reagents*—Reagent grade chemicals shall be used in all tests. Unless otherwise indicated, it is intended that all reagents shall conform to the specifications of the Committee on Analytical Reagents of the American Chemical Society, where such specifications are available.⁵ Other grades may be used, provided it is first ascertained that the reagent is of sufficiently high purity to permit its use without lessening the accuracy of the determination.

7.2 *Purity of Water*— Unless otherwise indicated, references to water shall be understood to mean Type II or Type III reagent water conforming to Specification D 1193.

7.3 *Acetic Acid-Chloroform Solvent (2 + 1)*—Mix 2 volumes of acetic acid with 1 volume of chloroform.

7.4 *Acetic Acid-Chloroform Solvent (Containing Approximately 4% Water)*—Add 40 mL of water to 1 L of solvent prepared as described in 7.3.

7.5 *Iodine*.

7.6 *Nitrogen Cylinder*.

7.7 *Potassium Iodide Solution (50 %)*—Dissolve 20 g of potassium iodide (KI) in 20 mL of de-aerated water. This reagent should be freshly prepared just prior to use.

7.8 *Water, De-aerated*—Pass nitrogen through distilled water for several minutes prior to use.

8. Procedure

8.1 *High Range—0 to 400 µg of Active Oxygen:*

8.1.1 *Preparation of Calibration Curve:*

8.1.1.1 Dissolve 0.1270 g of iodine in acetic acid-chloroform solvent (2 + 1) and dilute to 100 mL in a volumetric flask. This solution contains 1.27 mg of iodine/mL, which is equivalent to 80.0 µg of active oxygen/mL.

8.1.1.2 Transfer 0, 1, 2, 3, 4, and 5-mL aliquots of this solution to 25-mL volumetric flasks and dilute each to volume with the acetic acid-chloroform solvent. Mix thoroughly.

8.1.1.3 Using a hypodermic needle or glass capillary, sparge the solution with nitrogen for 1 to 1.5 min, add 1 mL of freshly prepared KI solution, and continue the nitrogen flow for 1 min. Stopper and mix well.

8.1.1.4 Measure the absorbance of each solution at 470 nm, using 1-cm cells and a water reference.

8.1.1.5 Subtract the absorbance of the blank and plot the absorbance of each standard against micrograms of active oxygen per 25 mL.

ASTM E299-08

<https://standards.iteh.ai/catalog/standards/sist/c2f45b66-02aa-4958-b948-a940c59b69a0/astm-e299-08>

⁵ *Annual Book of ASTM Standards*, Vol 15.05: Reagent Chemicals, American Chemical Society Specifications, American Chemical Society, Washington, DC. For suggestions on the testing of reagents not listed by the American Chemical Society, see *Analar Standards for Laboratory Chemicals*, BDH Ltd., Poole, Dorset, U.K., and the *United States Pharmacopeia and National Formulary*, U.S. Pharmacopeial Convention, Inc. (USPC), Rockville, MD.

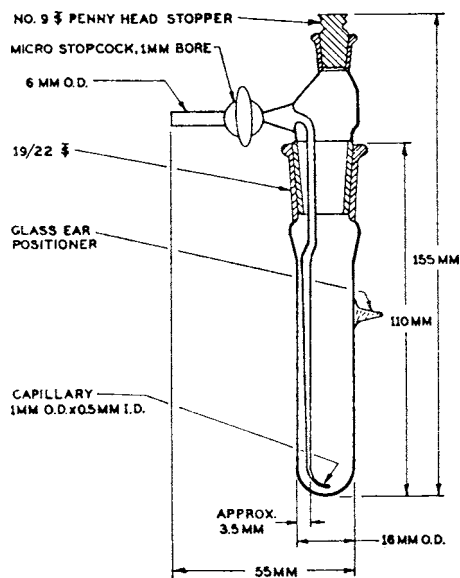

FIG. 1 Absorption Cell for Low-Active Oxygen