Light conveyor belts — Determination of electrical resistances

*Courroies transporteuses légères — Détermination des résistances
électriques*

iTeh STANDARD PREVIEW
(standards.iteh.ai)

[ISO 21178:2013](https://standards.iteh.ai/catalog/standards/sist/da8ee8e5-6f58-4e1e-b139-4f8f2f1f03a8/iso-21178-2013)

<https://standards.iteh.ai/catalog/standards/sist/da8ee8e5-6f58-4e1e-b139-4f8f2f1f03a8/iso-21178-2013>



iTeh STANDARD PREVIEW
(standards.iteh.ai)

ISO 21178:2013

<https://standards.iteh.ai/catalog/standards/sist/da8ee8e5-6f58-4e1e-b139-4f82f1f03a8/iso-21178-2013>



COPYRIGHT PROTECTED DOCUMENT

© ISO 2013

All rights reserved. Unless otherwise specified, no part of this publication may be reproduced or utilized otherwise in any form or by any means, electronic or mechanical, including photocopying, or posting on the internet or an intranet, without prior written permission. Permission can be requested from either ISO at the address below or ISO's member body in the country of the requester.

ISO copyright office
Case postale 56 • CH-1211 Geneva 20
Tel. + 41 22 749 01 11
Fax + 41 22 749 09 47
E-mail copyright@iso.org
Web www.iso.org

Published in Switzerland

Contents

	Page
Foreword	iv
1 Scope	1
2 Normative references	1
3 Symbols	1
4 Electrical surface resistances	2
4.1 Method A: measurement of surface resistance R_{OA} omni-directionally	2
4.2 Method B: measurement of surface resistance R_{OB} in longitudinal and transverse direction	5
5 Electrical surface resistivity ρ_s	7
5.1 General	7
5.2 Principle	7
5.3 Apparatus	7
5.4 Preparation and preservation of test pieces prior to testing	9
5.5 Procedure	9
5.6 Expression of results	10
5.7 Test report	10
6 Electrical volume resistances	10
6.1 Volume resistance R_D perpendicular to plane of belt	10
6.2 Volume resistance R_{Di} in longitudinal and transverse direction parallel to plane of belt	15
7 Electrical volume resistivity ρ_D	18
7.1 Procedure	18
7.2 Expression of results	18
7.3 Test report	18
Annex A (informative) Comparative values for electrical resistances	19
Bibliography	20

Foreword

ISO (the International Organization for Standardization) is a worldwide federation of national standards bodies (ISO member bodies). The work of preparing International Standards is normally carried out through ISO technical committees. Each member body interested in a subject for which a technical committee has been established has the right to be represented on that committee. International organizations, governmental and non-governmental, in liaison with ISO, also take part in the work. ISO collaborates closely with the International Electrotechnical Commission (IEC) on all matters of electrotechnical standardization.

International Standards are drafted in accordance with the rules given in the ISO/IEC Directives, Part 2.

The main task of technical committees is to prepare International Standards. Draft International Standards adopted by the technical committees are circulated to the member bodies for voting. Publication as an International Standard requires approval by at least 75 % of the member bodies casting a vote.

Attention is drawn to the possibility that some of the elements of this document may be the subject of patent rights. ISO shall not be held responsible for identifying any or all such patent rights.

ISO 21178 was prepared by Technical Committee ISO/TC 41, *Pulleys and belts (including veebelts)*, Subcommittee SC 3, *Conveyor belts*.

This second edition cancels and replaces the first edition (ISO 21178:2005), of which it constitutes a minor revision.

iTeh STANDARD PREVIEW
(standards.iteh.ai)

[ISO 21178:2013](https://standards.iteh.ai/catalog/standards/sist/da8ee8e5-6f58-4e1e-b139-4f82f1f03a8/iso-21178-2013)

<https://standards.iteh.ai/catalog/standards/sist/da8ee8e5-6f58-4e1e-b139-4f82f1f03a8/iso-21178-2013>

Light conveyor belts — Determination of electrical resistances

1 Scope

This International Standard specifies test methods for determining the electrical resistances of light conveyor belts according to ISO 21183-1. The resistances are surface resistance, volume resistance perpendicular to the belt plane, and longitudinal and transverse volume resistance parallel to the belt plane. This International Standard also specifies two test methods for determining the surface resistivity and the volume resistivity.

2 Normative references

The following documents, in whole or in part, are normatively referenced in this document and are indispensable to its application. For undated references, the latest edition of the referenced document (including any amendments) applies.

ISO 18573, *Conveyor belts — Test atmospheres and conditioning periods*

3 Symbols

Symbol	Quantity	Unit
R_{OA}	Electrical surface resistance, method A	Ω
R_{OB}	Electrical surface resistance, method B	Ω
R_{OG}	Electrical surface resistance for the determination of ρ_s	Ω
R_D	Electrical volume resistance perpendicular to the plane of the belt	Ω
R_{Di}	Electrical volume resistance in longitudinal and transverse direction parallel to the plane of the belt	Ω
ρ_s	Electrical surface resistivity	Ω
ρ_D	Electrical volume resistivity	$\Omega \cdot \text{cm}$
$d_{1/2/3}$	Diameter of electrode	cm
d_m	Middle of the gap diameter	cm
g	Width of the gap	cm
A	Surface of the electrode	cm^2
h	Thickness of test piece	cm

NOTE The SI unit of surface resistivity, ρ_s , is the ohm (Ω). In practice, this is sometimes referred to as "ohm/square" or " Ω/sq " or " Ω/\square ". The size of the square is immaterial.

4 Electrical surface resistances

4.1 Method A: measurement of surface resistance R_{OA} **omni-directionally**

4.1.1 Applicability

This method is applicable to belts which are electrically two-dimensionally isotropic in the plane of the belt.

4.1.2 Principle

An electric current of specified voltage is passed via electrodes through a suitably prepared test piece taken from the belt.

4.1.3 Apparatus

4.1.3.1 Sheet of insulating material, a little larger than the test piece

4.1.3.2 Two cylindrical and coaxial brass electrodes, the base of one being circular and that of the other annular. The dimensions and masses are given in [Figure 2](#). The bases of these electrodes shall be machined flat and polished.

4.1.3.3 Flexible insulated wire, connected to each electrode.

4.1.3.4 Ohmmeter, having a measuring range up to $10^{10} \Omega$ and accurate to within $\pm 5\%$.

4.1.3.5 Source of direct current, adjustable up to 500 V, and not permitting a current greater than 10 mA.

NOTE The source of current can be either an accumulator or a rectified, stabilized a.c. power supply.

4.1.4 Test piece

4.1.4.1 Material

Test piece material shall be new, unused ("virgin"), but shall not be tested sooner than five days after manufacture. It shall be free from contamination and superficial damage.

4.1.4.2 Dimensions

The test pieces shall be square, 300 mm \times 300 mm minimum, and shall be cut from the full thickness of the belt.

4.1.4.3 Number

Three test pieces shall be taken. One test piece shall be taken from the middle of the belt, the other two test pieces shall be taken 100 mm from each of the belt edges.

4.1.4.4 Cleaning

If necessary, clean both surfaces of the test pieces by rubbing with fuller's earth (hydrated magnesium-aluminium silicate), for example, using a clean cloth. After cleaning away all traces of the powder, wipe the surface with a clean cloth moistened with distilled water and then dry with a clean cloth.

4.1.4.5 Conditioning

Before testing, condition the test pieces in accordance with ISO 18573, Atmosphere B, for 24 h, except that, if the light conveyor belt consists of materials with a high absorption of moisture, e.g. cotton or polyamide, condition the test piece for 48 h.

4.1.4.6 Preparation

Prepare the test pieces in the following manner after conditioning according to [4.1.4.5](#).

To ensure good contact between electrodes and test piece a contact agent shall be used. The electrical surface resistivity of the contact agent shall not be higher than $10^4 \Omega$. For checking this value, use the same electrode arrangement as described in [Clause 5](#).

NOTE A jelly having the following composition is suitable:

- anhydrous polyethylene glycol of molecular mass 600: 800 mg/g (mass fraction);
- water: 200 mg/g (mass fraction);
- potassium chloride: 10 mg/g (mass fraction);
- soft soap (pharmaceutical quality): 1 mg/g (mass fraction).

If the surface of the test piece is flat, paint the contact agent onto the bottom surface of the cleaned electrodes. If the surface of the test piece is textured, paint two areas of the test piece as shown in [Figure 1](#). Take care to ensure the accuracy of the dimensions of the painted areas, although the symmetry of the centre is not critical. Carry out the test immediately after painting. If silver lacquer is used as the contact agent, carry out the test after evaporating the solvent.

4.1.5 Procedure

ISO 21178:2013

<https://standards.iteh.ai/catalog/standards/sist/da8ee8e5-6f58-4e1e-b139-3b1d1e1e1e1e>

Measure the temperature and relative humidity in the test room.

Place the test piece on the sheet of insulating material, with the test surface upwards.

Paint the test piece or bottom surface of the cleaned electrodes with contact agent and let the solvent evaporate, if necessary.

If necessary, clean the electrodes and place them on the test piece.

Apply the test voltage to the electrodes, starting with a low voltage to protect very fine antistatic layers against damage.

Read the value of the electrical resistance 1 min after applying the test voltage.

Dimensions in millimetres

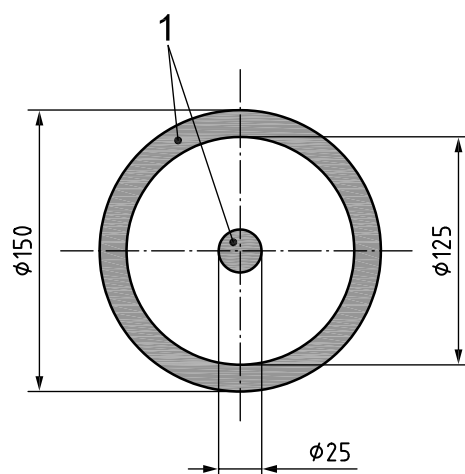

Key

- 1 contact agent

Figure 1 — Design to be painted on the test piece

Dimensions in millimetres

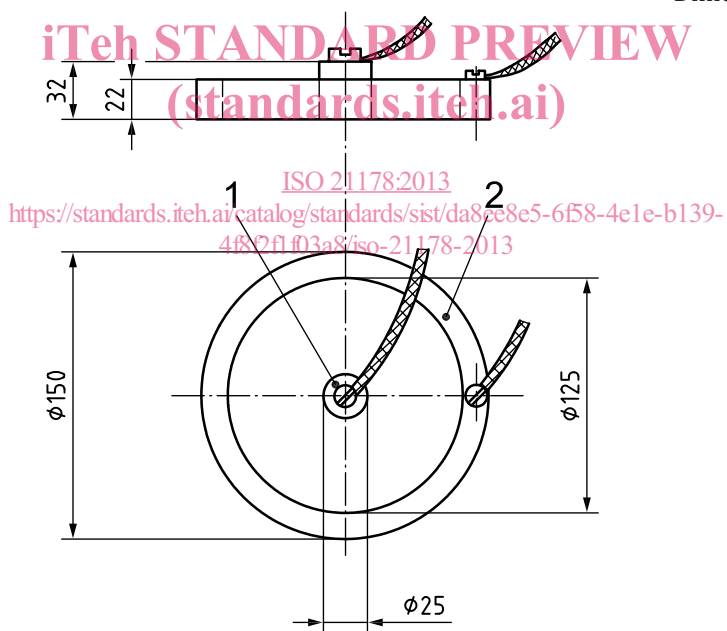

Key

- 1 min. mass 115 g
- 2 min. mass 900 g

Figure 2 — Electrodes

4.1.6 Expression of results

For each surface of the belt subjected to test, record the electrical resistance, in ohms, measured for each test piece, and calculate the mean of the values recorded for that surface for the three test pieces.

Record the electrical resistance for the two surfaces of the belt separately.

4.1.7 Test report

The test report shall include the following information:

- a) complete designation of the tested light conveyor belt material and the manufacturing date;
- b) reference to this International Standard, i.e. ISO 21178;
- c) test room temperature and relative humidity;
- d) conditioning period;
- e) contact agent applied;
- f) voltage applied to the electrodes;
- g) results of the tests;
- h) date of test;
- i) any deviations from the standard test.

4.2 Method B: measurement of surface resistance R_{OB} in longitudinal and transverse direction

4.2.1 Applicability

This method is applicable to belts which have electrically varying properties in the plane of the belt, especially those where fabrics have conducting threads in the longitudinal direction which may be exposed on the belt surface.

ISO 21178:2013

4.2.2 Principle <https://standards.iteh.ai/catalog/standards/sist/da8ee8e5-6f58-4e1e-b139-4f82ff03a8/iso-21178-2013>

An electric current is passed via electrodes clamped in a suitable arrangement to the surface of a test piece of the belt material.

4.2.3 Apparatus (see [Figure 3](#))

4.2.3.1 Earthed screen plate

4.2.3.2 Bottom plate, made of insulating material, such as polymethylmethacrylate, polytetrafluoroethylene or similar, having dimensions 600 mm × 200 mm × 20 mm.

4.2.3.3 Brass electrodes, with connection points for the ohmmeter connecting cables, having a contact area of 100 mm × 10 mm.

4.2.3.4 Electrode holders

4.2.3.5 Ohmmeter, having a measuring range up to $10^{10} \Omega$ and accurate to within $\pm 5 \%$.

4.2.3.6 Source of direct current, adjustable up to 500 V, and not permitting a current greater than 10 mA.

NOTE The source current can be either an accumulator or a rectified, stabilized a.c. power supply.

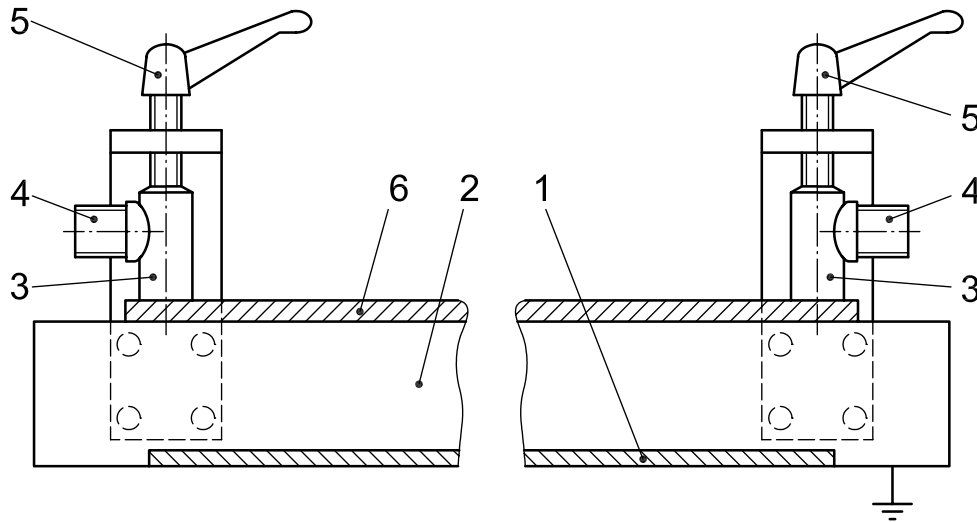

- Key**
- 1 screen plate, earthed
 - 2 bottom plate
 - 3 electrodes
 - 4 connection points
 - 5 electrode holder
 - 6 test piece

iTeh STANDARD PREVIEW
(standards.iteh.ai)

Figure 3 — Test arrangement for measurement of electrical surface resistance R_{OB}

ISO 21178:2013

<https://standards.iteh.ai/catalog/standards/sist/da8ee8e5-6f58-4e1e-b139-4f8f2f1f03a8/iso-21178-2013>

4.2.4 Test piece

4.2.4.1 Material

Test piece material shall be new, unused (“virgin”), but shall not be tested sooner than five days after manufacture. It shall be free of any kind of contamination or superficial damage.

4.2.4.2 Dimensions

The test pieces, 500 mm long × 100 mm wide, shall be cut from the full thickness of the light conveyor belt in the longitudinal or transverse direction.

4.2.4.3 Number

Three test pieces shall be taken. One test piece shall be taken from the middle of the belt, the other two test pieces shall be taken 100 mm from each of the belt edges.

4.2.4.4 Conditioning

Condition the test pieces in accordance with [4.1.4.5](#).

4.2.4.5 Preparation

To ensure good contact between electrodes and test piece a suitable contact agent shall be used. Its electrical surface resistivity shall not be higher than $10^4 \Omega$ (see [4.1.4.6](#)).

4.2.5 Procedure

Measure the temperature and relative humidity in the test room.

Place the test piece on the insulating plate so that the warp is exactly at right angles to the long axes of the electrodes.

Place the electrodes on top of the test piece and clamp them in position.

Apply the test voltage to the electrodes starting with a low voltage to protect fine conducting layers against damage.

Read the value of the electrical resistance 1 min after applying the test voltage.

4.2.6 Expression of results

See [4.1.6](#).

4.2.7 Test report

See [4.1.7](#).

5 Electrical surface resistivity ρ_s

5.1 General

This electrical surface resistivity is calculated from the electrical surface resistance R_{OG} , determined with a different electrode arrangement to that used in [4.1](#). This method is applicable to the same types of belt to which the method described in [4.1](#) applies.

NOTE 1 See [Annex A](#). <https://standards.iteh.ai/catalog/standards/sist/da8ee8e5-6f58-4e1e-b139-4f82f1f03a8/iso-21178-2013>

NOTE 2 The unit is the ohm (Ω) but is also written Ω/sq or Ω/\square (see [Clause 3](#), footnote 1).

5.2 Principle

An electric current of specified voltage is passed via electrodes through a suitably prepared test piece taken from the belt.

5.3 Apparatus

5.3.1 Three electrodes, see [Figures 4](#) and [5](#), having the following diameters: $d_1 = 50$ mm, $d_2 = 60$ mm, $d_3 = 80$ mm, and $d_m = [(d_1 + d_2)/2]$ mm.