INTERNATIONAL STANDARD



1519

INTERNATIONAL ORGANIZATION FOR STANDARDIZATION • МЕЖДУНАРОДНАЯ ОРГАНИЗАЦИЯ ПО СТАНДАРТИЗАЦИИ • ORGANISATION INTERNATIONALE DE NORMALISATION

Paints and varnishes — Bend test (cylindrical mandrel)

First edition — 1973-12-15

iTeh STANDARD PREVIEW
(standards.iteh.ai)

[ISO 1519:1973](https://standards.iteh.ai/catalog/standards/sist/56e9ace4-1f0c-47dd-858a-d31f7d23f57b/iso-1519-1973)

<https://standards.iteh.ai/catalog/standards/sist/56e9ace4-1f0c-47dd-858a-d31f7d23f57b/iso-1519-1973>

UDC 667.61 : 620.177.3

Ref. No. ISO 1519-1973 (E)

Descriptors : paints, varnishes, tests, bend tests.

Price based on 5 pages

FOREWORD

ISO (the International Organization for Standardization) is a worldwide federation of national standards institutes (ISO Member Bodies). The work of developing International Standards is carried out through ISO Technical Committees. Every Member Body interested in a subject for which a Technical Committee has been set up has the right to be represented on that Committee. International organizations, governmental and non-governmental, in liaison with ISO, also take part in the work.

Draft International Standards adopted by the Technical Committees are circulated to the Member Bodies for approval before their acceptance as International Standards by the ISO Council.

Prior to 1972, the results of the work of the Technical Committees were published as ISO Recommendations; these documents are now in the process of being transformed into International Standards. As part of this process, International Standard ISO 1519 replaces ISO Recommendation R 1519-1970 drawn up by Technical Committee ISO/TC 35, *Paints and varnishes*.

ISO 1519:1973

The Member Bodies of the following countries approved the Recommendation:

Australia	Iran	South Africa, Rep. of
Austria	Ireland	Spain
Denmark	Israel	Sweden
Egypt, Arab Rep. of	Italy	Switzerland
France	Netherlands	Turkey
Germany	Peru	United Kingdom
Greece	Poland	U.S.S.R.
India	Portugal	

No Member Body expressed disapproval of the Recommendation.

Paints and varnishes – Bend test (cylindrical mandrel)

0 INTRODUCTION

This International Standard is one of a series dealing with the sampling and testing of paints, varnishes and related products. It should be read in conjunction with ISO 1512, ISO 1513, and ISO 1514.

This International Standard is one of three which specify empirical test procedures for assessing the resistance of coatings of paints, varnishes and related products to cracking and/or detachment from the substrate under different conditions of deformation. The other two of these documents are ISO 1520, *Paints and varnishes – Cupping test*, and ISO¹⁾ *Paints and varnishes – Rapid deformation test*.

The method of test specified requires to be completed, for any particular application, by the following supplementary information. This information should be derived from the national standard or other document for the product under test or, where appropriate, should be the subject of agreement between the interested parties.

- a) Nature, thickness and surface preparation of substrate.
- b) Apparatus to be used (i.e. Type 1 or Type 2).
- c) Method of application of test coating to substrate.
- d) Thickness, in micrometres, of the dry coating, including method of measurement, and whether it is a single coating or a multicoat system.
- e) Duration and conditions of drying of the coated panel before testing (or conditions of stoving and ageing, if applicable).
- f) Specified size of mandrel, if applicable, to be used in the test.
- g) Temperature at which the test is to be carried out.

1 SCOPE AND FIELD OF APPLICATION

1.1 This International Standard specifies an empirical test procedure for assessing the resistance of a coating of paint, varnish or related product to cracking and/or detachment

from a metal substrate when subjected to bending round a cylindrical mandrel under standard conditions.

1.2 For a multicoat system, each coat may be tested separately or the complete system may be tested.

1.3 The method specified may be carried out

either as a "go/no go" test, by carrying out the test with a single specified size of mandrel, to assess compliance with a particular requirement

or by repeating the procedure using successively smaller mandrels to determine the diameter of the first mandrel over which the coating cracks and/or becomes detached from the substrate.

1.4 Two types of apparatus are specified, Type 1 being appropriate for use on test panels of thickness up to 0,3 mm, and Type 2 for use on test panels of thickness up to 1,0 mm. Both types of apparatus have been found to give similar results with the same coating, but normally only one will be used for testing a given product.

2 REFERENCES

ISO 1512, *Paints and varnishes – Sampling*.

ISO 1513, *Paints and varnishes – Examination and preparation of samples for testing*.

ISO 1514, *Paints and varnishes – Standard panels for testing*.

ISO 2808, *Paints and varnishes – Determination of film thickness*.

3 APPARATUS

3.1 Bend test apparatus

3.1.1 Material

In both types of apparatus specified below, the mandrels shall be made of a rigid and suitably corrosion-resistant material, for example stainless steel.

1) In preparation. (See ISO/TR 6272)

3.1.2 Type 1 apparatus

A suitable apparatus is shown in figures 1 and 2 and is used with test panels of thickness not greater than 0,3 mm. A set of hinges is provided, each incorporating a cylindrical mandrel; the diameters of the mandrels are 2, 3, 4, 5, 6, 8, 10, 12, 16, 20, 25 and 32 mm respectively¹⁾. The dimensions of the apparatus are not critical, except that the gap between the surface of the mandrel and the plates of the hinges shall be $0,55 \pm 0,05$ mm. The mandrel shall be free to rotate on its axis and the apparatus shall be provided with a stop to ensure that when the test panel is bent, the two portions are parallel.

3.1.3 Type 2 apparatus

A suitable apparatus is shown in figures 3 and 4 and is normally used with test panels of thickness up to 1,0 mm. With soft metals, for example aluminium, thicker panels may be used provided there is no distortion of the mandrel. The apparatus incorporates one of a series of cylindrical mandrels of diameters 6, 10 and 13 mm²⁾.

3.2 Controlled temperature chamber

This is required for tests which are specified to be carried out at temperatures other than 23 ± 2 °C. It consists of an oven or refrigerator in which the temperature of the working chamber can be controlled to within ± 1 °C of the required test temperature, and fitted with the following ancillary equipment :

- a) a circulation fan in the working chamber;
- b) a suitable remote-control device by which the panel can be bent without opening the test chamber;
- c) a temperature indicating or recording device located with its bulb or sensitive element in close proximity to the coating under test.

4 SAMPLING

A representative sample of the product to be tested (or of each product in the case of a multicoat system) shall be taken as specified in ISO 1512. The sample shall then be examined and prepared for testing as specified in ISO 1513.

5 TEST PANELS

5.1 Material

Unless otherwise specified or agreed, the test panels shall be of burnished steel, burnished tinplate or soft aluminium complying with the requirements of ISO 1514.

5.2 General

The test panels shall be flat and free from distortion and the surface shall be free from any visible ridges or cracks.

5.3 Dimensions

The test panels shall be rectangular and approximately 100 mm × 50 mm in size and either 0,3 mm (for use with Type 1 apparatus) or 1,0 mm (for use with Type 2 apparatus) thick, unless otherwise specified. The test panels may be cut to size after coating and drying, provided no distortion occurs. In the case of aluminium panels, the longer side shall be parallel to the longitudinal direction of metallurgical rolling.

5.4 Preparation and coating of panels

The test panels shall be prepared in accordance with ISO 1514, unless otherwise specified, and shall then be coated by the specified method with the product under test. If the product under test is applied by brushing, the brush marks shall be parallel to the longer side of the panel.

5.5 Thickness of coating

The thickness, in micrometres, of the dry coating shall be determined by the method specified, using one of the procedures specified in ISO 2808.

6 PROCEDURE

6.1 General

6.1.1 Drying the test panel

The coated test panels shall be dried (or stoved and aged) for the specified time and, unless otherwise specified, shall be conditioned at a temperature of 23 ± 2 °C and 50 ± 5 % relative humidity for a minimum period of 16 h. The appropriate test procedure shall then be carried out as soon as possible.

6.1.2 Ambient conditions

The test shall be carried out at a temperature of 23 ± 2 °C and 50 ± 5 % relative humidity, unless otherwise specified.

6.1.3 Handling the test panel

Warming the test panel by undue handling shall be avoided.

6.2 Procedure for a single specified size of mandrel

The appropriate procedure given in 6.2.1, 6.2.2 or 6.2.3 shall be carried out on two separate test panels and the panels shall then be examined as specified in 6.2.4 (if the results differ, additional tests shall be made).

1) Especially with the 2 mm diameter mandrel, it is important to ensure that no distortion of the mandrel takes place during the bending process, and not to use any mandrel showing such distortion.

2) By agreement between the interested parties, other diameters of mandrel may be used with the Type 2 apparatus.

6.2.1 Tests with the Type 1 apparatus at $23 \pm 2^\circ\text{C}$

Fully open the apparatus, fitted with the appropriate mandrel, and insert the panel so that it may subsequently be bent with the coated side outwards.

Close the apparatus evenly without jerking, over a period of from 1 to 2 s, thus bending the panel over the mandrel through 180° .

6.2.2 Tests with the Type 2 apparatus at $23 \pm 2^\circ\text{C}$

Firmly secure the apparatus near the edge of a bench so that the handle can be operated freely. Lower the panel holder by withdrawing the wedge and use the adjusting screw to move the bending piece away from the mandrel position. Fit the apparatus with the appropriate mandrel. Lower the handle into a vertical position and then insert the panel, painted side down, between the mandrel and the bending piece, until approximately 40 mm of the panel protrudes when measured from the mandrel centre line towards the bending piece. Clamp the panel firmly to the panel holder using the lock nuts and plate. Raise the panel holder by inserting the wedge into its groove until the panel just touches the mandrel. Using the adjusting screw, raise the bending piece until it just touches the panel. Lift the handle evenly through 180° without jerking, over a period of from 1 to 2 s, thus bending the panel over the mandrel through 180° .

NOTE — A piece of thin paper may be inserted over the coated surface between the panel holder and the bending piece to prevent the coating being scratched during the bending operation.

After bending, release the panel by moving the bending piece away from the mandrel, lowering the panel holder by removing the wedge and unscrewing the lock nuts.

6.2.3 Tests at temperatures other than $23 \pm 2^\circ\text{C}$

Open the apparatus fitted with the appropriate mandrel and place the panel in position so that it may subsequently be bent with the coated side outwards. Place the apparatus containing the panel in the test chamber previously adjusted to the specified temperature. After 2 h, with the panel still in the chamber at the specified temperature, close the apparatus evenly and without jerking by means of the remote-control device, over a period of from 1 to 2 s. It is essential that the door of the chamber shall remain closed from the time of insertion of the apparatus until after the bending operation.

6.2.4 Examination of the test panel

Examine the test panel cotaing immediately after bending and, in the case of the Type 1 apparatus, without removing the panel from the apparatus. Use normal corrected vision

or, by agreement, a lens of $\times 10$ magnification, and examine the coating for cracking and/or detachment from the substrate, ignoring the surface of the coating less than 10 mm from the edge of the panel.

NOTE — If a lens is used, it is essential to mention this fact in the test report and to avoid misleading comparisons with results obtained using normal vision only.

6.3 Procedure for determination of diameter of the first mandrel to cause failure

Carry out the appropriate procedure given in 6.2.1, 6.2.2 or 6.2.3 on successive test panels, examining each panel as specified in 6.2.4 and using mandrels of successively smaller diameter until the coating cracks and/or becomes detached from the substrate. Record the diameter of the first mandrel at which the coating cracks and/or becomes detached, after confirming the result by repeating the procedure with this size of mandrel on a fresh panel. In the event of failure not occurring with the mandrel of the smallest diameter, record this fact.

7 TEST REPORT

The test report shall include the following information :

- a) a reference to this International Standard or to a corresponding national standard;
- b) the type and identification of the product under test;
- c) the items of supplementary information referred to in the Introduction to this International Standard;
- d) the national standard or other document supplying the information referred to in c) above;
- e) any deviation, by agreement or otherwise, from the test procedure specified;
- f) the result of the test; report as required (stating whether normal corrected vision or a lens was used) :
 - *either* for each determination, the extent of any cracking and/or detachment of the coating from the substrate, with the specified size of mandrel,
 - *or* the diameter of the first mandrel at which the coating cracked and/or became detached from the substrate; or the fact that failure did not occur with the smallest diameter mandrel used, in which case the diameter of that mandrel shall also be stated;
- g) the date of the test.

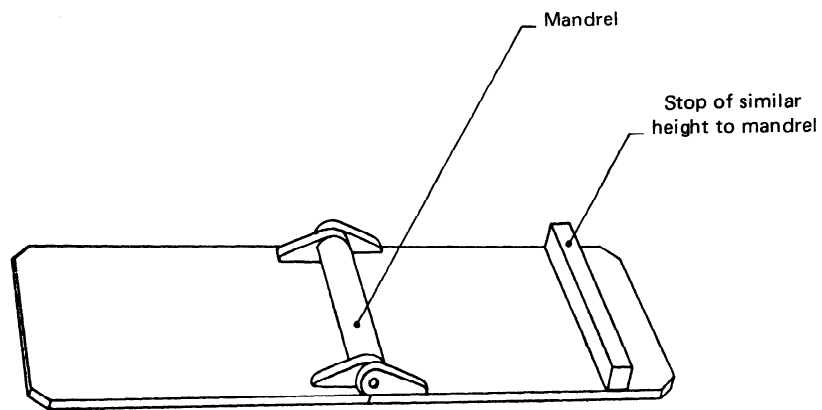

FIGURE 1 – Type 1 bend test apparatus

iTeh STANDARD PREVIEW
(standards.iteh.ai)

[ISO 1519:1973](https://standards.iteh.ai/catalog/standards/sist/56e9ace4-1f0c-47dd-858a-d31f7d23f57b/iso-1519-1973)

<https://standards.iteh.ai/catalog/standards/sist/56e9ace4-1f0c-47dd-858a-d31f7d23f57b/iso-1519-1973>

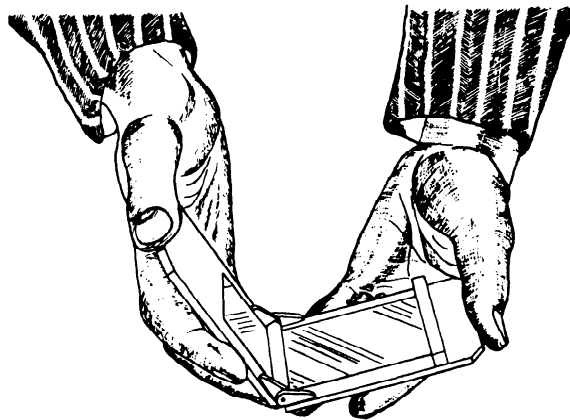

FIGURE 2 – Type 1 bend test apparatus in use

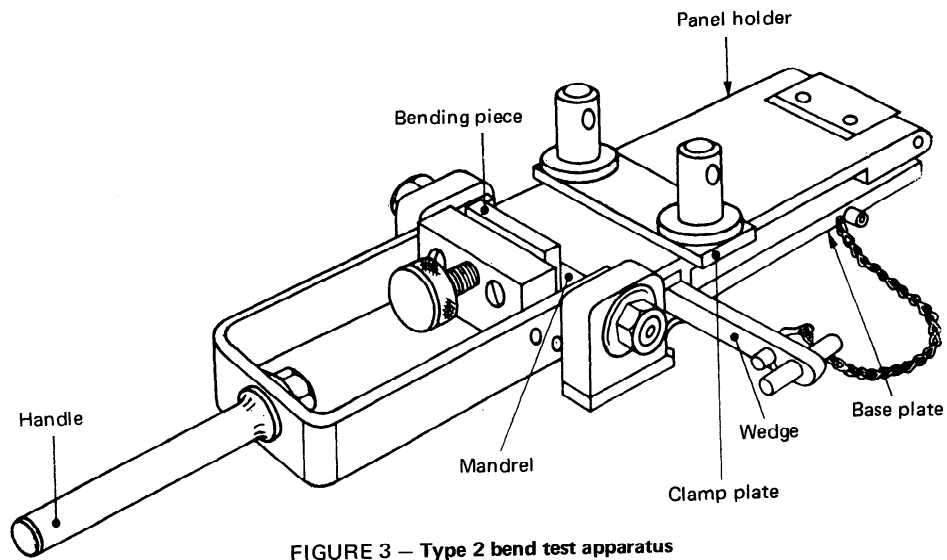

FIGURE 3 – Type 2 bend test apparatus

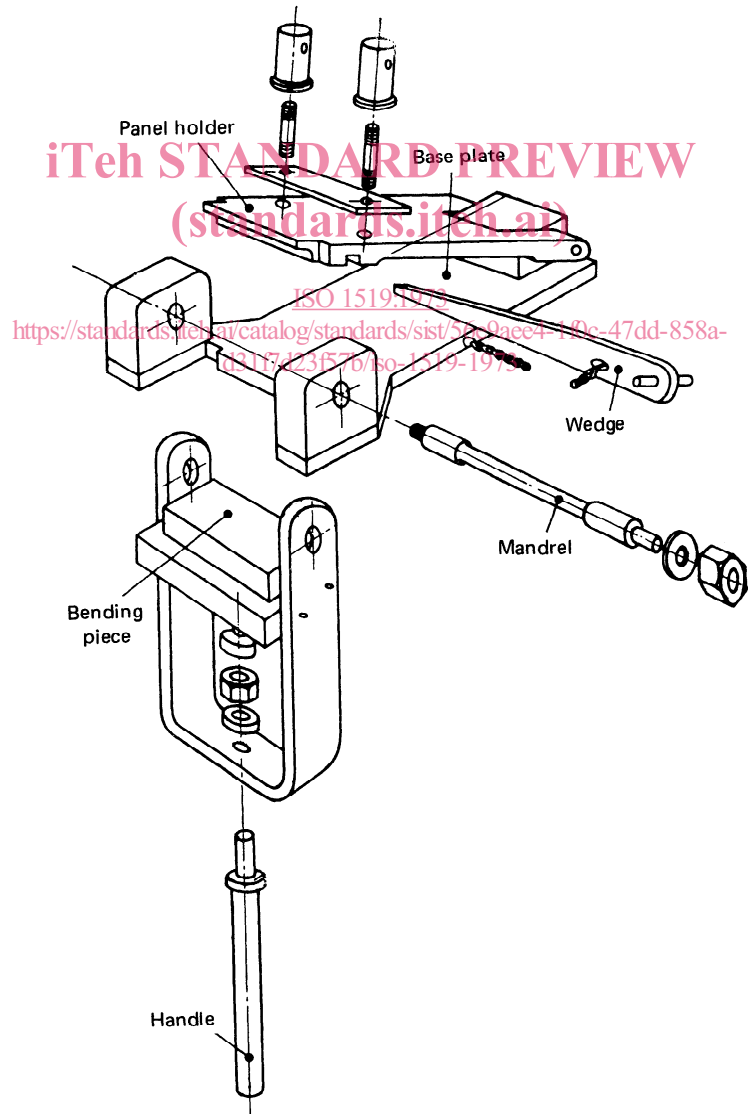

FIGURE 4 – Details of Type 2 bend test apparatus