

---

# INTERNATIONAL STANDARD



# 1520

---

INTERNATIONAL ORGANIZATION FOR STANDARDIZATION • МЕЖДУНАРОДНАЯ ОРГАНИЗАЦИЯ ПО СТАНДАРТИЗАЦИИ • ORGANISATION INTERNATIONALE DE NORMALISATION

---

## Paints and varnishes — Cupping test

First edition — 1973-12-15

**iTeh STANDARD PREVIEW**  
**(standards.iteh.ai)**

[ISO 1520:1973](https://standards.iteh.ai/catalog/standards/sist/a39cde30-3059-4b78-ac68-94225d6e30b3/iso-1520-1973)

<https://standards.iteh.ai/catalog/standards/sist/a39cde30-3059-4b78-ac68-94225d6e30b3/iso-1520-1973>

---

UDC 667.61 : 620.178.15

Ref. No. : ISO 1520-1973 (E)

**Descriptors** : paints, varnishes, tests, ductility tests.

Price based on 3 pages

## FOREWORD

ISO (the International Organization for Standardization) is a worldwide federation of national standards institutes (ISO Member Bodies). The work of developing International Standards is carried out through ISO Technical Committees. Every Member Body interested in a subject for which a Technical Committee has been set up has the right to be represented on that Committee. International organizations, governmental and non-governmental, in liaison with ISO, also take part in the work.

Draft International Standards adopted by the Technical Committees are circulated to the Member Bodies for approval before their acceptance as International Standards by the ISO Council.

Prior to 1972, the results of the work of the Technical Committees were published as ISO Recommendations; these documents are now in the process of being transformed into International Standards. As part of this process, International Standard ISO 1520 replaces ISO Recommendation R 1520-1970 drawn up by Technical Committee ISO/TC 35, *Paints and varnishes*.

<https://standards.iteh.ai/catalog/standards/sist/a39cde30-3059-4b78-ae68-94225d6e30b3/iso-1520-1973>

The Member Bodies of the following countries approved the Recommendation:

Australia	Iran	Spain
Austria	Ireland	Sweden
Denmark	Israel	Switzerland
Egypt, Arab. Rep. of	Italy	Turkey
France	Peru	United Kingdom
Germany	Poland	U.S.S.R.
Greece	Portugal	
India	South Africa, Rep. of	

The Member Body of the following country expressed disapproval of the Recommendation on technical grounds:

Netherlands

# Paints and varnishes – Cupping test

## 0 INTRODUCTION

This International Standard is one of a series dealing with the sampling and testing of paints, varnishes and related products. It should be read in conjunction with ISO 1512, ISO 1513 and ISO 1514.

This International Standard is one of three which specify empirical test procedures for assessing the resistance of coatings of paints, varnishes and related products to cracking and/or detachment from the substrate under different conditions of deformation. The other two of these documents are ISO 1519, *Paints and varnishes – Bend test (cylindrical mandrel)*, and ISO ...,<sup>1)</sup> *Paints and varnishes – Rapid deformation test*.

The method of test specified requires to be completed, for any particular application, by the following supplementary information. This information shall be derived from the national standard or other document for the product under test or, where appropriate, shall be the subject of agreement between the interested parties.

- a) Nature, thickness and surface preparation of substrate.
- b) Method of application of test coating to substrate.
- c) Thickness, in micrometres, of the dry coating, including method of measurement, and whether it is a single coating or a multicoat system.
- d) Duration and conditions of drying of the coated panel before testing (or conditions of stoving and ageing, if applicable).
- e) The specified depth of indentation, if applicable, at which the test is to be carried out.

## 1 SCOPE AND FIELD OF APPLICATION

1.1 This International Standard specifies an empirical test procedure for assessing the resistance of a coating of paint, varnish or related product to cracking and/or detachment

from a metal substrate when subjected to gradual deformation by indentation under standard conditions.

1.2 For a multicoat system, each coat may be tested separately or the complete system may be tested.

1.3 The method specified may be carried out

*either* as a "go/no go" test, by testing to a specified depth of indentation to assess compliance with a particular requirement;

*or* by gradually increasing the depth of indentation to determine the minimum depth at which the coating cracks and/or becomes detached from the substrate.

ISO 1520:1973

http://www.iso.org/standards/std/a39cde30-3059-4b78-ae68-5e22d6c30b/iso-1520-1973

## 2 REFERENCES

ISO 1512, *Paints and varnishes – Sampling*.

ISO 1513, *Paints and varnishes – Examination and preparation of samples for testing*.

ISO 1514, *Paints and varnishes – Standard panels for testing*.

ISO 2808, *Paints and varnishes – Determination of film thickness*.

## 3 APPARATUS

3.1 The cupping test apparatus shall comply with the design and dimensions shown in the figure and shall consist essentially of the following :

3.1.1 **Die.** This is surface hardened and the surface in contact with the test panel is plane polished.

3.1.2 **Retaining ring.** The surface in contact with the test panel is plane polished and parallel to the contacting surface of the die.

1) In preparation.

**3.1.3 Indenter.** The part contacting the test panel is of hardened polished steel and forms a hemisphere of 20 mm diameter. During the test the indenter shall be prevented from turning and the centre of the spherical portion shall not deviate from the axis of the die by more than 0,1 mm.

**3.1.4 Measuring device.** This measures the depth of the indentation made by the indenter to the nearest 0,05 mm.

**3.2** The surface of the die, retaining ring and indenter which come into contact with the test panel shall be smooth, rust-free and clean.

**3.3** The tip of the hemisphere, when at the zero position, shall be in the same plane as the face of the retaining ring, in contact with the test panel and shall be in the centre of the bore of the die.

**3.4** It is preferable to use a mechanically driven indenter, but a hand-operated apparatus is also acceptable, provided that it enables the standard conditions of test (see clause 6) to be achieved.

## 4 SAMPLING

A representative sample of the product to be tested (or of each product in the case of a multicoat system) shall be taken as specified in ISO 1512. The samples shall then be examined and prepared for testing as specified in ISO 1513.

## 5 TEST PANELS

### 5.1 Material

Unless otherwise specified, the test panels shall be of burnished steel, complying with the requirements of ISO 1514.

### 5.2 General

The test panels shall be flat and free from distortion.

### 5.3 Dimensions

The test panels shall be rectangular with the following dimensions :

- thickness : not less than 0,3 mm and not more than 1,25 mm (as specified and measured with a micrometer to the nearest 0,01 mm);
- width and length : at least 70 mm (upper limit depending on the capacity of the apparatus).

The test panels may be cut to size after coating and drying, provided no distortion occurs.

## 5.4 Preparation and coating of panels

The test panels shall be prepared in accordance with ISO 1514, unless otherwise specified, and shall then be coated by the specified method with the product or system under test.

## 5.5 Thickness of coating

The thickness, in micrometres, of the dry coating shall be determined by the method specified, using one of the procedures specified in ISO 2808.

## 6 PROCEDURE

### 6.1 General

#### 6.1.1 *Drying the test panel*

The coated test panels shall be dried (or stoved and aged) for the specified time and, unless otherwise specified, shall be conditioned at a temperature of  $23 \pm 2$  °C and  $50 \pm 5$  % relative humidity for a minimum time of 16 h. The appropriate test procedure shall then be carried out as soon as possible.

#### 6.1.2 *Ambient conditions*

The test shall be carried out at a temperature of  $23 \pm 2$  °C and  $50 \pm 5$  % relative humidity, unless otherwise specified.

### 6.2 Procedure for a single specified depth of indentation

The following procedure shall be carried out on two separate test panels (if the results differ, additional tests shall be made).

**6.2.1** Hold the test panel firmly between the retaining ring and the die with the coating towards the die and with the hemispherical end of the indenter in contact with the test panel (zero position of the indenter). Adjust the panel until the central axis of the indenter intersects the panel at least 35 mm from each edge.

**6.2.2** Advance the hemispherical end of the indenter into the test piece at a constant rate of  $0,2 \pm 0,1$  mm/s until the specified depth is reached, i.e. until the indenter has travelled this distance from the zero position.

**6.2.3** Using normal corrected vision or, by agreement, a lens of X 10 magnification, examine the coating of the test panel for cracking and/or detachment from the substrate.

### NOTES

- 1 If a lens is used, it is essential to mention this fact in the test report and to avoid misleading comparisons with results obtained using normal vision only.
- 2 The test results shall not be regarded as valid if the substrate shows signs of cracking.

**6.3 Procedure for determination of minimum depth of indentation to cause failure**

Carry out the procedure given in 6.2 until, using normal corrected vision (or, by agreement, a lens of X 10 magnification), a crack is first observed on the surface of the coating and/or the coating begins to become detached from the substrate<sup>1)</sup>. Stop the indenter at this point and measure the depth of indentation (see figure) to the nearest 0,1 mm, i.e. the distance travelled by the indenter from the zero position. Confirm the result by repeating the determination on a fresh panel (if the results differ, further determinations shall be made).

**7 TEST REPORT**

The test report shall include the following information :

- a) a reference to this International Standard or to a corresponding national standard;
- b) the type and identification of the product under test;

- c) the items of supplementary information referred to in the Introduction to this International Standard;
- d) the national standard or other document supplying the information referred to in e) above;
- e) any deviation, by agreement or otherwise, from the test procedure specified;
- f) a statement as to whether a mechanically driven or a hand-operated indenter was used;
- g) the result of the test; report as required (stating whether normal corrected vision or a lens was used) :

— *either*, for each determination, the extent of any cracking and/or detachment of the cracking from the substrate, at the specified depth of indentation,

— *or* the depth of indentation, to the nearest 0,5 mm at which the coating started to crack and/or started to detach from the substrate;

- h) the date of the test.

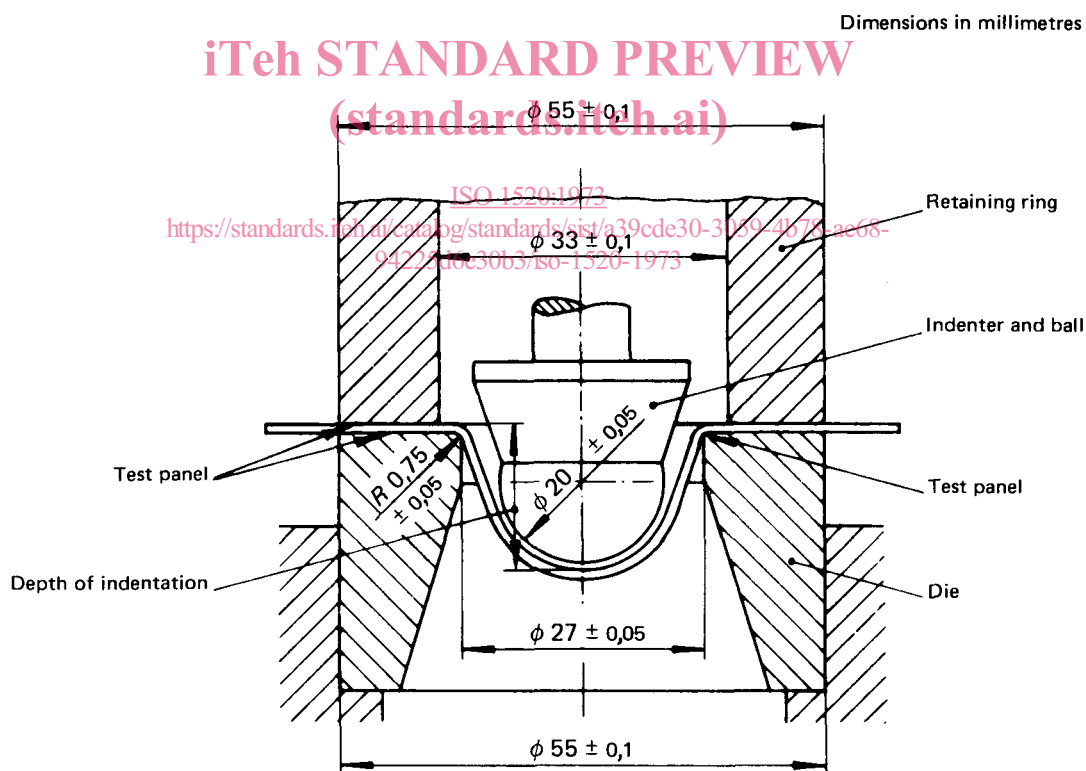

FIGURE – Cupping test apparatus

1) In order to facilitate accurate observation of the end point, it is permissible to reduce slightly the rate of advance of the indenter when approaching the expected end point (determined, if necessary, in a preliminary test).

**iTeh STANDARD PREVIEW**  
**(standards.iteh.ai)**

ISO 1520:1973

<https://standards.iteh.ai/catalog/standards/sist/a39cde30-3059-4b78-ae68-94225d6e30b3/iso-1520-1973>

**iTeh STANDARD PREVIEW**  
**(standards.iteh.ai)**

ISO 1520:1973

<https://standards.iteh.ai/catalog/standards/sist/a39cde30-3059-4b78-ae68-94225d6e30b3/iso-1520-1973>

**iTeh STANDARD PREVIEW**  
**(standards.iteh.ai)**

ISO 1520:1973

<https://standards.iteh.ai/catalog/standards/sist/a39cde30-3059-4b78-ae68-94225d6e30b3/iso-1520-1973>