

Second edition
2008-07-15

AMENDMENT 1
2014-04-15

**Road vehicles — Test methods
for electrical disturbances from
electrostatic discharge**

AMENDMENT 1

*Véhicules routiers — Méthodes d'essai des perturbations électriques
provenant de décharges électrostatiques*

AMENDEMENT 1

iTeh STANDARD PREVIEW
(standards.iteh.ai)

ISO 10605:2008/Amd 1:2014

<https://standards.iteh.ai/catalog/standards/sist/01757613-4255-4df1-97ae-dd56ec56b87a/iso-10605-2008-amd-1-2014>



Reference number
ISO 10605:2008/Amd.1:2014(E)

© ISO 2014

iTeh STANDARD PREVIEW (standards.iteh.ai)

[ISO 10605:2008/Amd 1:2014](https://standards.iteh.ai/catalog/standards/sist/01757613-4255-4df1-97ae-dd56ec56b87a/iso-10605-2008-amd-1-2014)
<https://standards.iteh.ai/catalog/standards/sist/01757613-4255-4df1-97ae-dd56ec56b87a/iso-10605-2008-amd-1-2014>



COPYRIGHT PROTECTED DOCUMENT

© ISO 2014

All rights reserved. Unless otherwise specified, no part of this publication may be reproduced or utilized otherwise in any form or by any means, electronic or mechanical, including photocopying, or posting on the internet or an intranet, without prior written permission. Permission can be requested from either ISO at the address below or ISO's member body in the country of the requester.

ISO copyright office
Case postale 56 • CH-1211 Geneva 20
Tel. + 41 22 749 01 11
Fax + 41 22 749 09 47
E-mail copyright@iso.org
Web www.iso.org

Published in Switzerland

Foreword

ISO (the International Organization for Standardization) is a worldwide federation of national standards bodies (ISO member bodies). The work of preparing International Standards is normally carried out through ISO technical committees. Each member body interested in a subject for which a technical committee has been established has the right to be represented on that committee. International organizations, governmental and non-governmental, in liaison with ISO, also take part in the work. ISO collaborates closely with the International Electrotechnical Commission (IEC) on all matters of electrotechnical standardization.

The procedures used to develop this document and those intended for its further maintenance are described in the ISO/IEC Directives, Part 1. In particular the different approval criteria needed for the different types of ISO documents should be noted. This document was drafted in accordance with the editorial rules of the ISO/IEC Directives, Part 2. www.iso.org/directives

Attention is drawn to the possibility that some of the elements of this document may be the subject of patent rights. ISO shall not be held responsible for identifying any or all such patent rights. Details of any patent rights identified during the development of the document will be in the Introduction and/or on the ISO list of patent declarations received. www.iso.org/patents

Any trade name used in this document is information given for the convenience of users and does not constitute an endorsement.

For an explanation on the meaning of ISO specific terms and expressions related to conformity assessment, as well as information about ISO's adherence to the WTO principles in the Technical Barriers to Trade (TBT) see the following URL: Foreword - Supplementary information

The committee responsible for this document is ISO/TC 22, *Road vehicles*, Subcommittee SC 3, *Electric and electronic equipments*.

[ISO 10605:2008/Amd 1:2014](https://standards.iteh.ai/catalog/standards/sist/01757613-4255-4df1-97ae-dd56ec56b87a/iso-10605-2008-amd-1-2014)

<https://standards.iteh.ai/catalog/standards/sist/01757613-4255-4df1-97ae-dd56ec56b87a/iso-10605-2008-amd-1-2014>

iTeh STANDARD PREVIEW
(standards.iteh.ai)

[ISO 10605:2008/Amd 1:2014](https://standards.iteh.ai/catalog/standards/sist/01757613-4255-4df1-97ae-dd56ec56b87a/iso-10605-2008-amd-1-2014)

<https://standards.iteh.ai/catalog/standards/sist/01757613-4255-4df1-97ae-dd56ec56b87a/iso-10605-2008-amd-1-2014>

Road vehicles — Test methods for electrical disturbances from electrostatic discharge

AMENDMENT 1

Page 5, Table 2

Replace: “charge voltage” with “test voltage”. Replace Table 2 with the following.

Table 2 — Contact discharge mode current specifications

Typical capacitance/ resistance values	Peak current/ test voltage A/kV	Tolerance %	Current at t_1 / test voltage A/kV	Tolerance %	Current at t_2 / test voltage A/kV	Tolerance %
150 pF/330 Ω	3,75	± 10	2 (at $t_1 = 30$ ns)	± 30	1 (at $t_2 = 60$ ns)	± 30
330 pF/330 Ω	3,75	± 10	2 (at $t_1 = 65$ ns)	± 30	1 (at $t_2 = 130$ ns)	± 30
150 pF/2 000 Ω	3,75	± 30	0,275 (at $t_1 = 180$ ns)	± 30	0,15 (at $t_2 = 360$ ns)	± 50
330 pF/2 000 Ω	3,75	± 30	0,275 (at $t_1 = 400$ ns)	± 30	0,15 (at $t_2 = 800$ ns)	± 50

NOTE 1 The peak current level is taken from the measurement system without any data interpolation.

NOTE 2 The target used with this measurement system fulfils the requirements of A.1 and A.2. An example is defined in Annex B.

NOTE 3 The measurement times (30 ns, 60 ns, 65 ns, 130 ns, 180 ns, 360 ns, 400 ns and 800 ns) are derived from the resistance-capacitive (RC) time constant -40 % (current t_1) and $+20$ % (current t_2), to define two values on the falling slope of the current pulse in accordance with IEC 61000-4-2.

Pages 19 to 21, Annex A

Replace the following in Annex A (see below).

In the second sentence of A.2.3.1, replace: “Table A.1” with “Table 1”.

At the beginning of the first paragraph of A.2.3.4, add: “The measurement discharge current procedure is shown in Table A.1”.

Replace the title of Table A.1: “Contact discharge verification procedure” with “Contact discharge current waveform verification procedure”.

Replace: “output voltage” with “test voltage” and replace: “charge voltage” with “test voltage”.

A.2.3.1 Prior to verifying the discharge current, the amplitude of the ESD generator’s test voltage should be determined using a high-voltage meter at the electrode tip. The accuracy of the test voltage measurement shall be as specified in Table 1.

NOTE The verification of electrode output voltage should consider electrical structure of ESD generator (e.g. electrical circuit structure) and specification (e.g. input impedance and input stray capacitance) of high-voltage meter for correct measuring.

A.2.3.4 The measurement discharge current procedure is shown in Table A.1. The following parameters shall be measured, or obtained from measured values, in order to verify whether or not the current waveform of an ESD generator is within specifications:

- I_p , the peak value of the discharge current, in A;
- I_1 , the value of the current at t_1 , in A (from Table 2);
- I_2 , the value of the current at t_2 , in A (from Table 2);
- t_r , the rise time of the current, in ns.

The average value of a parameter X_x is indicated by \bar{X}_x .

EXAMPLE \bar{I}_p signifies the average of the peak current values.

Table A.1 — Contact discharge current waveform verification procedure

Step	Resistance				Explanation
	330 Ω	2 kΩ	150 pF	330 pF	
Discharge the ESD generator at a given test voltage 10 times, store each result					Multiple measurements are taken as the acceptance criteria are given for parameters obtained on the average value by this 10 times discharge data. This is done because there will be some discharge-to-discharge variations.
Measure I_p , I_1 , I_2 and t_r on each waveform					The parameters have to be checked at each test level.
Calculate the averages \bar{I}_p , \bar{I}_1 , \bar{I}_2 and \bar{t}_r of the measured I_p , I_1 , I_2 and t_r values					Average is taken on the parameters, not by averaging the waveforms. This way, any jitter on the trigger will not influence the averaging.

Table A.1 (continued)

Step	Resistance				Explanation
	330 Ω		2 kΩ		
	Capacitance		Capacitance		
	150 pF	330 pF	150 pF	330 pF	
Check: current at t_1 /test voltage (A/kV)	Check if $\bar{I}_1 = 2 \pm 30 \%$	Check if $\bar{I}_1 = 2 \pm 30 \%$	Check if $\bar{I}_1 = 0,275 \pm 30 \%$	Check if $\bar{I}_1 = 0,275 \pm 30 \%$	Again, compliance of the ESD gen- erator is verified on the average of the parameter.
Check: current at t_2 /test voltage (A/kV)	Check if $\bar{I}_2 = 1 \pm 30 \%$	Check if $\bar{I}_2 = 1 \pm 30 \%$	Check if $\bar{I}_2 = 0,15 \pm 50 \%$	Check if $\bar{I}_2 = 0,15 \pm 50 \%$	Again, compliance of the ESD gen- erator is verified on the average of the parameter.
Check: peak current/test voltage (A/kV)	Check if $\bar{I}_p = 3,75 \pm 10 \%$		Check if $\bar{I}_p = 3,75^{+30}_0 \%$		Again, compliance of the ESD gen- erator is verified on the average of the parameter.
Check rise time	Check if $0,7 \text{ ns} \leq \bar{t}_r \leq 1 \text{ ns}$				

iTeH STANDARD PREVIEW
(standards.iteh.ai)

Pages 33 to 34, Annex B

ISO 10605:2008/Amd 1:2014

Add to Figure B.8, key item 6, the following text: "(between attenuator A and network analyser and between attenuator B and network analyser)".

In B.2.3, in the paragraph following Figure B.8, delete: "(between attenuator and target and between attenuator and target adapter line)".

In B.2.4, in the first list item following Figure B.9, replace: "output voltage" with "voltage".

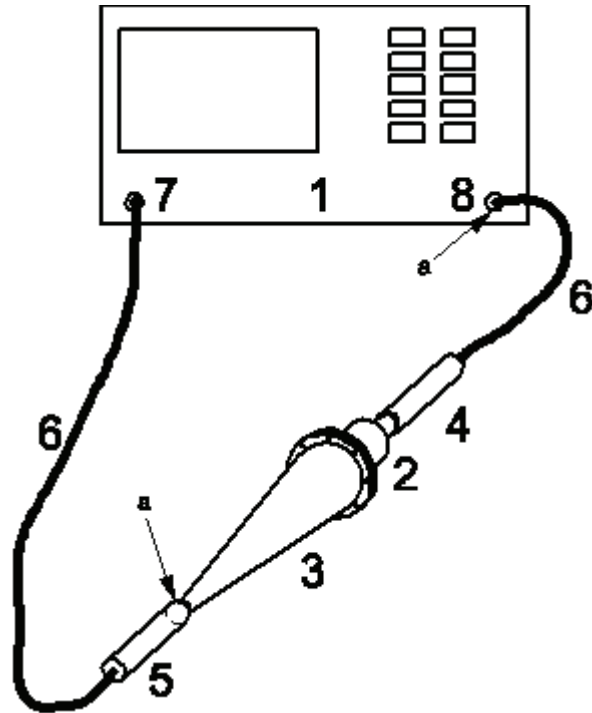

Key

- 1 network analyser
- 2 ESD current target
- 3 50 Ω conical adapter line
- 4 attenuator A
- 5 attenuator B
- 6 coaxial cable (between attenuator A and network analyser and between attenuator B and network analyser)

- 7 network analyser output connector
- 8 network analyser input connector

NOTE The ESD current target, attenuator A and the coaxial cable are the target-attenuator-cable chain, which is verified using this set-up.

^a Calibrate the network analyser at these points.

Figure B.8 — Network analyser measurement of the insertion loss of a current target-attenuator-cable chain

The measurement procedure for the insertion loss is to calibrate the network analyser at the verification points shown in Figure B.8.

B.2.4 Determining the d.c. transfer resistance of a target-attenuator-cable chain

The d.c. system transfer resistance of the target-attenuator-cable chain may be determined by the method below.

- Inject a current I_{sys} of approximately 1 A into the front side of the current target. The front side is the side to which discharges are made. The current shall be known within ±1 %. Larger currents may be used if they do not thermally stress the target beyond its specifications. Measure the test voltage, V , across the precision 50 Ω load.

Replace the paragraph following list item c) with the following, replacing “charge voltage” with “test voltage”.

Due to the complexity of air discharge, no satisfactory verification method has been developed. Therefore it was decided not to require an air discharge verification. The operator should be aware that using a fully compliant contact mode generator in the air discharge testing mode can result in a small or very large rate of ESD current change (for the same generator electrode test voltage) between discharges. This is exactly what happens in realistic air discharge ESD events.

Pages 45 to 46, Figures F.1 and F.2

Insert the following new Figures F.2 and F.3.

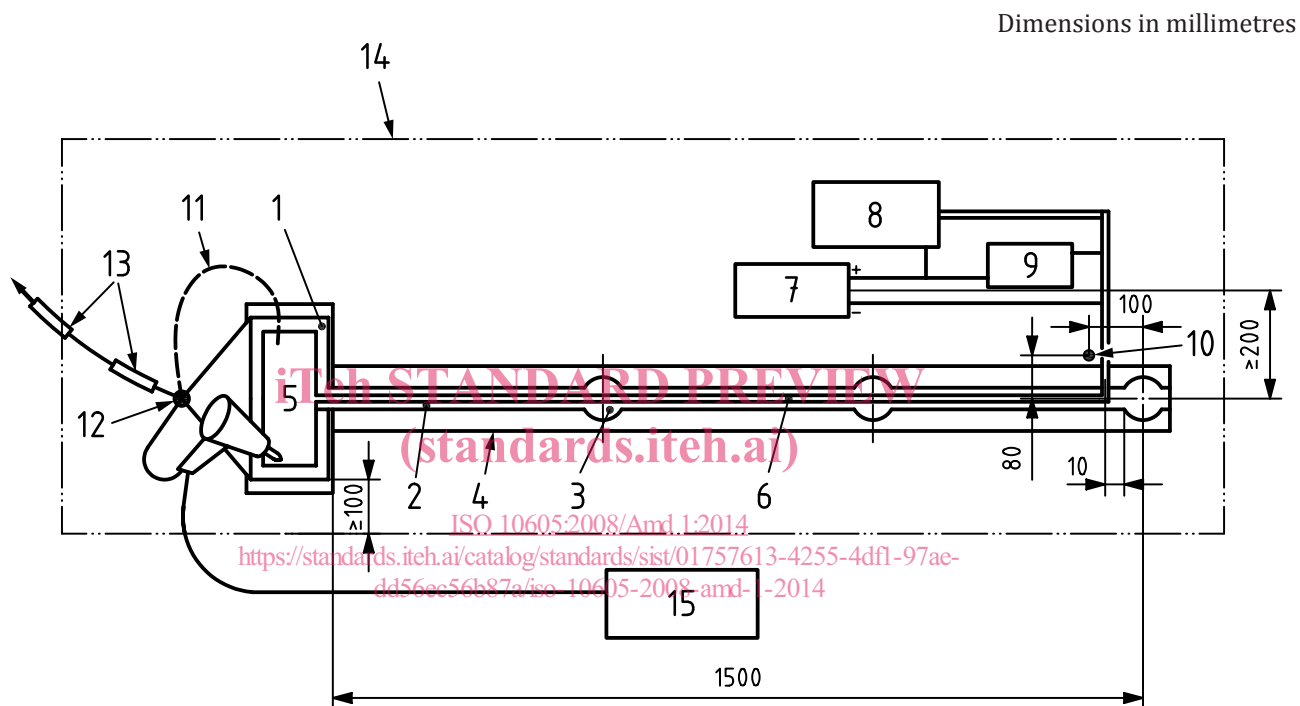

Key

- | | | | |
|---|--|----|---|
| 1 | field coupling plane | 9 | artificial network (AN) (if used) |
| 2 | field coupling strip | 10 | ground reference point for battery and support equipment |
| 3 | discharge island | 11 | DUT local ground (if required) |
| 4 | DUT and wiring harness isolation block | 12 | ground reference point for ESD coupling plane, ESD generator and safety ground connection |
| 5 | DUT | 13 | 2 × 470 kΩ high-voltage resistors to safety ground |
| 6 | DUT wiring harness | 14 | HCP |
| 7 | battery | 15 | ESD generator main unit |
| 8 | peripheral or support equipment | | |

NOTE The tolerance of dimensions is ±5 %.

Figure F.2 — Test set-up — Application of direct discharges