



Designation: B 956 – 07^{ε1}

Standard Specification for Welded Copper and Copper-Alloy Condenser and Heat Exchanger Tubes with Integral Fins¹

This standard is issued under the fixed designation B 956; the number immediately following the designation indicates the year of original adoption or, in the case of revision, the year of last revision. A number in parentheses indicates the year of last reapproval. A superscript epsilon (ϵ) indicates an editorial change since the last revision or reapproval.

^{ε1} NOTE—Added table reference to 5.2.4.

1. Scope

1.1 This specification establishes the requirements for heat exchanger tubes manufactured from forge-welded copper and copper alloy tubing in straight lengths on which the external or internal surface, or both, has been modified by cold forming process to produce an integral enhanced surface for improved heat transfer.

1.2 *Units*—The values stated in either inch-pounds units or SI units are to be regarded separately as the standard. Within the text, the SI units are shown in brackets. The values stated in each system are not exact equivalents; therefore, each system shall be used independently of the other. Combining values from the two systems could result in nonconformance with the specification.

1.3 The tubes are typically used in surface condensers, evaporators, and heat exchangers.

1.4 The product shall be produced of the following coppers or copper alloys, as specified in the ordering information.

Copper or Copper Alloy	Type of Metal
UNS No.	
C12000 ^A	DLP Phosphorized, low residual phosphorus
C12200 ^A	DHP Phosphorized, high residual phosphorus
C19200	Phosphorized, 1 % iron
C23000	Red Brass
C44300	Admiralty, arsenical
C44400	Admiralty, antimonial
C44500	Admiralty, phosphorized
C68700	Aluminum Brass
C70400	95-5 Copper-Nickel
C70600	90-10 Copper-Nickel
C70620	90-10 Copper-Nickel (Modified for Welding)
C71000	80-20 Copper-Nickel
C71500	70-30 Copper-Nickel
C71520	70-30 Copper-Nickel (Modified for Welding)
C72200	Copper-Nickel

^A Copper UNS Nos. C12000, and C12200 are classified in Classification B 224.

NOTE 1—Designations listed in Classification B 224.

1.5 *The following safety hazard caveat pertains only to the test methods described in this specification. This standard does*

¹ This specification is under the jurisdiction of ASTM Committee B05 on Copper and Copper Alloys and is the direct responsibility of Subcommittee B05.04 on Pipe and Tube.

Current edition approved Oct. 1, 2007. Published November 2007.

not purport to address all of the safety concerns, if any, associated with its use. It is the responsibility of the user of this standard to establish appropriate safety and health practices and determine the applicability of regulatory limitations prior to use.

2. Referenced Documents

2.1 ASTM Standards:²

- B 153 Test Method for Expansion (Pin Test) of Copper and Copper-Alloy Pipe and Tubing
- B 154 Test Method for Mercurous Nitrate Test for Copper Alloys
- B 224 Classification of Coppers
- B 543 Specification for Welded Copper and Copper-Alloy Heat Exchanger Tube
- B 601 Classification for Temper Designations for Copper and Copper Alloys—Wrought and Cast
- B 846 Terminology for Copper and Copper Alloys
- B 858 Test Method for Ammonia Vapor Test for Determining Susceptibility to Stress Corrosion Cracking in Copper Alloys
- E 8 Test Methods for Tension Testing of Metallic Materials
- E 29 Practice for Using Significant Digits in Test Data to Determine Conformance with Specifications
- E 53 Test Method for Determination of Copper in Unalloyed Copper by Gravimetry
- E 54 Test Methods for Chemical Analysis of Special Brasses and Bronzes³
- E 62 Test Methods for Chemical Analysis of Copper and Copper Alloys (Photometric Methods)
- E 112 Test Methods for Determining Average Grain Size
- E 118 Test Methods for Chemical Analysis of Copper-Chromium Alloys
- E 243 Practice for Electromagnetic (Eddy-Current) Examination of Copper and Copper-Alloy Tubes

² For referenced ASTM standards, visit the ASTM website, www.astm.org, or contact ASTM Customer Service at service@astm.org. For *Annual Book of ASTM Standards* volume information, refer to the standard's Document Summary page on the ASTM website.

³ Withdrawn. The last approved version of this historical standard is referenced on www.astm.org.

E 255 Practice for Sampling Copper and Copper Alloys for the Determination of Chemical Composition

E 478 Test Methods for Chemical Analysis of Copper Alloys

E 527 Practice for Numbering Metals and Alloys in the Unified Numbering System (UNS)

3. Terminology

3.1 For the definitions of terms related to copper and copper alloys, refer to Terminology B 846.

3.2 Definitions of Terms Specific to This Standard:

3.2.1 *enhanced tube*—tube having a series of metallic ribs on the outside or inside surface, or both, either parallel to the longitudinal axis or circumferentially extended from the tube to increase the effective surface for heat transfer (Figs. 1-3).

3.2.2 *unenanced tube*—tube made by processing strip into a tubular shape and forge welding the edges to make a longitudinal seam with no enhancements on the O.D. or I.D.

4. Types of Welded Tube

4.1 Reference Specification B 543 for the types of forge welded tube products that will be supplied for the enhancing operation (Section 6).

5. Ordering Information

5.1 Include the following information when placing orders for product under this specification as applicable:

- 5.1.1 ASTM designation and year of issue,
- 5.1.2 Copper UNS No. designation (for example, Copper UNS No. C12000),
- 5.1.3 Tube type (Section 4),
- 5.1.4 Temper (Section 8),
- 5.1.5 Dimensions, the diameter, wall thickness, whether minimum or nominal wall, and length (Section 14),
- 5.1.6 Configuration of enhanced surfaces shall be agree upon between the manufacturer and the purchaser (Figs. 1-3), and
- 5.1.7 Quantity.

5.2 The following options are available and shall be specified at the time placing the order, when required:

- 5.2.1 When heat identification or traceability is required,
- 5.2.2 Whether a pressure test is to be used instead of the eddy-current test (13.1),
 - 5.2.2.1 Whether a pressure test is be used along with the eddy-current test (13.3 and 13.4),
 - 5.2.2.3 Whether cut ends of the tube are to be deburred, chamfered, or otherwise treated (Section 15),
 - 5.2.2.4 If the product is to be subsequently welded (see Table 1, Footnote E),
 - 5.2.2.5 Certification, if required (Section 23), and
 - 5.2.2.6 Mill test report, if required (Section 24).

6. Materials and Manufacture

6.1 *Material:*

6.1.1 The material of manufacture shall be welded tube of one of the Copper Alloy UNS Nos. listed in 1.1 of such purity and soundness as to be suitable for processing into the products prescribed herein.

6.1.2 In the event heat identification or traceability is required, the purchaser shall specify the details desired.

6.2 *Manufacture:*

6.2.1 The product shall be manufacture by cold forming the enhancement of the heat transfer surfaces.

6.3 Product described by this specification shall typically be furnished with unenhanced ends, but may be furnished with enhanced ends or stripped ends from which the O.D. enhancement has been removed by machining.

6.3.1 The enhanced sections of the tube in the as-fabricated temper are in the cold formed condition produced by the enhancing operation.

6.3.2 The unenhanced sections of the tube shall be in the annealed or as-welded temper, and shall be suitable for rolling-in operations.

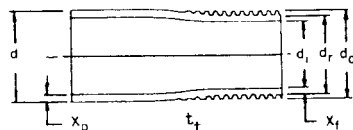

- d - Outside Diameter of Unenhanced Section
- d_o - Outside Diameter of the Enhanced Section
- d_r - Root Diameter of the Enhanced Section
- d_i - Inside Diameter of the Enhanced Section
- x_p - Wall Thickness of the Unenhanced Section
- x_r - Wall Thickness of the Unenhanced Section
- t_t - Transition Taper

NOTE—The outside diameter over the enhanced section will not normally exceed the outside diameter of the unenhanced section.

FIG. 1 Outside Diameter Enhanced Tube Nomenclature

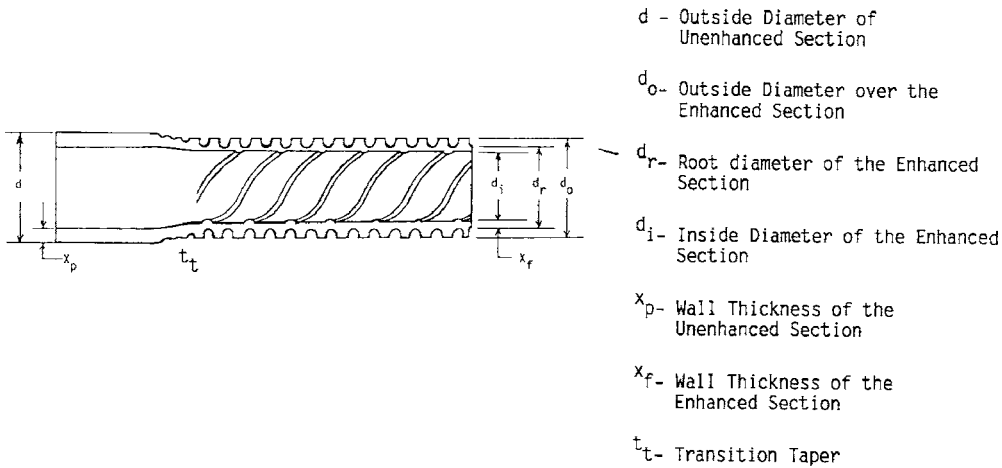

FIG. 2 Outside Diameter and Inside Diameter Enhanced Tube Nomenclature

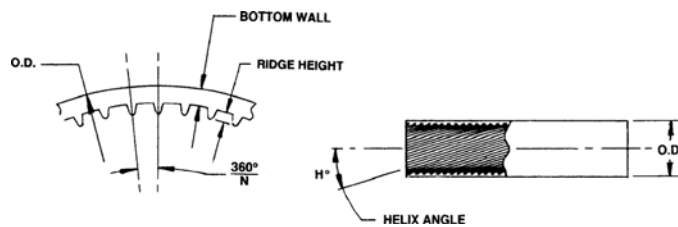

FIG. 3 Inside Diameter Enhanced Tube Nomenclature

TABLE 1 Chemical Requirements

Copper or Copper Alloy UNS No.	Composition, %												
	Copper	Tin	Aluminum	Nickel, incl Cobalt	Lead, max	Iron	Zinc	Manganese	Arsenic	Antimony	Phosphorus	Chromium	Other Named Elements
C12000	99.90 min ^A	0.004–0.012
C12200	99.9 min ^A	0.015–0.040
C19200	98.5 min ^B	0.8–1.2	0.20 max	0.01–0.04
C23000	84.0–86.0 ^B	0.05	0.05 max	remainder
C44300	70.0–73.0 ^C	0.9–1.2	0.07	0.06 max	remainder	...	0.02–0.06
C44400	70.0–73.0 ^C	0.9–1.2	0.07	0.06 max	remainder	...	0.02–0.10
C44500	70.0–73.0 ^C	0.9–1.2	0.07	0.06 max	remainder	0.02–0.10
C68700	76.0–79.0 ^{A,D}	...	1.8–2.5	...	0.07	0.06 max	remainder	...	0.02–0.06
C70400	remainder ^{A,D,E}	4.8–6.2	0.05	1.3–1.7	1.0 max	0.30–0.8
C70600	remainder ^{A,D}	9.0–11.0	0.05	1.0–1.8	1.0 max	1.0 max
C70620	86.5 min ^{A,D}	9.0–11.0	0.02	1.0–1.8	0.50 max	1.0 max	0.02 max	...	0.05 C max 0.02 S max
C71000	remainder ^{A,D,E}	19.0–23.0	0.05	1.0 max	1.0 max	1.0 max
C71500	remainder ^{A,D}	29.0–33.0	0.05	0.40–1.0	1.0 max	1.0 max
C71520	65.0 min ^{A,D}	29.0–33.0	0.02	0.40–1.0	0.50 max	1.0 max	0.02 max	...	0.05 C max 0.02 S max
C72200	remainder ^{A,B,E}	15.0–18.0	0.05	0.50–1.0	1.0 max	1.0 max	0.30–0.7	0.03 Si max 0.03 Ti max

^A Copper (including silver).

^B Cu + Sum of Named Elements, 99.8 % min.

^C Cu + Sum of Named Elements, 99.6 % min.

^D Cu + Sum of Named Elements, 99.5 % min.

^E When the product is for subsequent welding applications, and so specified in the contract or purchase order, zinc shall be 0.50 % max, lead 0.02 % max, phosphorus 0.02 % max, sulfur 0.02 % max, and carbon 0.05 % max.

7. Chemical Composition

7.1 The material shall conform to the chemical compositional requirements in Table 1 for Copper UNS No. designation specified in the ordering information.

7.2 The composition limits do not preclude the presence of other elements. By agreement between the manufacturer and purchaser, limits may be established and analysis required for unnamed elements.

7.2.1 *Copper Alloy C19200*—Copper may be taken as the difference between the sum of results for all specified elements and 100 %. When all elements specified, including copper, are determined, their sum shall be 99.8 % minimum.

7.2.2 For alloys in which copper is specified as the remainder, copper may be taken as the difference between the sum of the results for all specified elements and 100 % for the particular alloy.

7.2.2.1 When analyzed, copper plus the sum of results for specified elements shall conform with the requirements shown in the following table:

Copper Alloy UNS No.	Copper Plus Named Elements, % min
C70400	99.5
C70600	99.5
C70620	99.5
C71000	99.5
C71500	99.5
C71520	99.5
C72200	99.8

7.2.3 For alloys in which zinc is specified as the remainder, either copper or zinc may be taken as the difference between the sum of the results of specified elements analyzed and 100 %.

7.2.3.1 When all specified elements are determined, the sum of results plus copper shall be as follows:

Copper Alloy UNS No.	Copper Plus Named Elements, % min
C23000	99.8
C44300, C44400, C44500	99.6
C68700	99.5

8. Temper

8.1 Tempers, as defined in Classification **B 601** and this specification, are as follows:

8.1.1 The tube, after enhancing, shall be supplied, as specified, in the annealed (061) or as-fabricated temper.

8.1.1.1 The enhanced sections of tubes in the as-fabricated temper are in the cold formed condition produced by the fabricating operation.

8.1.1.2 The unenhanced sections of tubes in the as-fabricated temper are in the temper of the tube prior to enhancing, welded and annealed (WO61), welded and light cold-worked (WC55) and suitable for rolling-in operations.

8.2 Tubes of Copper Alloy UNS Nos. C23000, C44300, C44400, C44500, and C68700 shall be furnished in the annealed temper or the stress relieved condition as specified in the purchase order unless otherwise agreed upon between the purchaser and the manufacturer.

8.3 Tubes of Copper Alloy UNS Nos. C12200, C19400, C70400, C70600, C71000, C71500, and C72200 are normally supplied in the temper specified in the purchase order without stress relief treatment.

NOTE 2—Some tubes, when subjected to aggressive environments, may be subject to stress-corrosion cracking because of the residual tensile stresses developed in the enhancing process. For such applications, it is suggested that tubes of Copper Alloy UNS Nos. C23000, C44300, C44400, C44500, and C68700 are subjected to a stress relieving thermal treatment subsequent to the enhancing process. In Specification B 359 the stress relief anneal is mandatory for brass alloys.

9. Grain Size for Annealed Tempers

9.1 Samples of annealed temper tubes shall be examined at a magnification of 75 diameters. The grain size shall be determined in the wall beneath the internal enhancement. While there is not grain size range, the microstructure shall show complete recrystallization and the weld zone shall have a structure typical of hot-forged welds.

10. Mechanical Property Requirements

10.1 *Tensile Strength and Yield Strength Requirements:*

10.1.1 Product furnished under this specification shall conform to the tensile and yield strength requirements prescribed in **Table 2** when tested in accordance with Test Method **E 8**.

10.1.2 Acceptance or rejection based upon mechanical properties shall depend only on tensile strength and yield strength.

11. Performance Requirements

11.1 *Expansion Test Requirements:*

11.1.1 Product in the annealed tempers and the light cold-worked temper shall withstand expansion in accordance with Test Method **B 153** and to the extent in **Table 3**.

11.1.2 The expanded tube area shall be free of defects, but blemishes of nature that do not interfere with the intended application are acceptable.

11.2 *Flattening Test:*

11.2.1 When specified in the contract or purchase order, the flattening test described in the test method section in **19.2.7** shall be performed.

11.2.2 During inspection, the flattened areas and edges of the test specimen shall be free of defects, but blemishes of a nature that do not interfere with the intended application are acceptable.

11.3 *Reverse Bend Test:*

11.3.1 When specified in the contract or purchase order, the reverse bend test described in the test method section in **19.2.8** shall be performed on unenhanced tubes.

11.3.2 The sample shall be free of defects, but blemishes of nature that do not interfere with the intended application are acceptable.

12. Other Requirements

12.1 *Mercurous Nitrate Test or Ammonia Vapor Test:*

12.1.1 The mercurous nitrate or ammonia vapor test is required only for Copper Alloys UNS Nos. C23000; C44300; C44400; C44500; C60800; and C68700; when purchased if not supplied in an annealed temper (**Warning**—Mercury is a definite health hazard and therefore equipment for the detection and removal of mercury vapor produced in volatilization is recommended. The use of rubber gloves in testing is advisable.)

12.1.2 The test specimens, cut 6 in. [150 mm] in length from the enhanced section shall withstand, without cracking, an immersion in the standard mercurous nitrate solution in Test Method **B 154** or immersion in the ammonia vapor solution as defined in Test Method **B 858**.

12.1.3 Unless otherwise agreed upon between the manufacturer, or supplier, and the purchaser, the manufacturer shall