Plastics piping systems - End-load-bearing and non-end-load-bearing assemblies and joints for thermoplastics pressure piping - Test method for long-term leaktightness under internal water pressure (ISO 13846:2000)

Plastics piping systems - End-load-bearing and non-end-load-bearing assemblies and joints for thermoplastics pressure piping - Test method for long-term leaktightness under internal water pressure (ISO 13846:2000)

iTeh STANDARD PREVIEW
(standards.iteh.ai)
Kunststoff-Rohrleitungssysteme - Zugfeste und nicht-zugfeste Rohrverbindungen und Bauteilkombinationen für thermoplastische Druckrohrleitungen - Prüfverfahren für die Langzeitdichtheit unter Wasserinnendruck (ISO 13846:2000)

[SIST EN ISO 13846:2001](https://standards.iteh.ai/catalog/standards/sist/d97afb68-5d96-4094-bc93-1a21205d4a30/iso-13846-2000)

<https://standards.iteh.ai/catalog/standards/sist/d97afb68-5d96-4094-bc93-1a21205d4a30/iso-13846-2000>
Systemes de canalisations en plastiques - Assemblages et jonctions avec et sans effet de fond pour canalisations thermoplastiques avec pression - Méthode d'essai pour vérifier l'étanchéité a long terme sous une pression d'eau interne (ISO 13846:2000)

Ta slovenski standard je istoveten z: EN ISO 13846:2000

ICS:

23.040.60 Prirobnice, oglavki in spojni elementi Flanges, couplings and joints

SIST EN ISO 13846:2001**en**

iTeh STANDARD PREVIEW
(standards.iteh.ai)

[SIST EN ISO 13846:2001](#)

<https://standards.iteh.ai/catalog/standards/sist/d97afb68-5d96-4094-bc93-ce2479a2975d/sist-en-iso-13846-2001>

EUROPEAN STANDARD

EN ISO 13846

NORME EUROPÉENNE

EUROPÄISCHE NORM

October 2000

ICS 23.040.60

English version

Plastics piping systems - End-load-bearing and non-end-load-bearing assemblies and joints for thermoplastics pressure piping
- Test method for long-term leaktightness under internal water pressure (ISO 13846:2000)

Systèmes de canalisations en plastiques - Assemblages et jonctions avec et sans effet de fond pour canalisations thermoplastiques avec pression - Méthode d'essai pour vérifier l'étanchéité à long terme sous une pression d'eau interne (ISO 13846:2000)

Kunststoff-Rohrleitungssysteme - Zugfeste und nicht-zugfeste Rohrverbindungen und Bauteilkombinationen für thermoplastische Druckrohrleitungen - Prüfverfahren für die Langzeitdichtheit unter Wasserinnendruck (ISO 13846:2000)

This European Standard was approved by CEN on 24 April 1999.

CEN members are bound to comply with the CEN/CENELEC Internal Regulations which stipulate the conditions for giving this European Standard the status of a national standard without any alteration. Up-to-date lists and bibliographical references concerning such national standards may be obtained on application to the Management Centre or to any CEN member.

This European Standard exists in three official versions (English, French, German). A version in any other language made by translation under the responsibility of a CEN member into its own language and notified to the Management Centre has the same status as the official versions.

[SIST EN ISO 13846:2001](https://standards.iteh.ai/catalog/standards/sist/d97afb68-5d96-4094-bc93-)

<https://standards.iteh.ai/catalog/standards/sist/d97afb68-5d96-4094-bc93->
CEN members are the national standards bodies of Austria, Belgium, Czech Republic, Denmark, Finland, France, Germany, Greece, Iceland, Ireland, Italy, Luxembourg, Netherlands, Norway, Portugal, Spain, Sweden, Switzerland and United Kingdom.



EUROPEAN COMMITTEE FOR STANDARDIZATION
COMITÉ EUROPÉEN DE NORMALISATION
EUROPÄISCHES KOMITEE FÜR NORMUNG

Management Centre: rue de Stassart, 36 B-1050 Brussels

Contents

	Page
Foreword	3
1 Scope	4
2 Principle.....	4
3 Apparatus	4
3.1 Ambient temperatures.....	4
3.2 Elevated temperatures.....	4
3.3 Pressure control device	4
3.4 Support	5
3.5 Compensating device	5
4 Test piece	6
4.1 Preparation	6
4.2 Number	7
5 Procedure	7
5.1 Preparation	7
5.2 Conditioning.....	7
5.3 Pressure control.....	7
5.4 Examination of the test assembly	7
5.5 Examination at the mid-point and at the end of the test period.....	8
5.6 Rupture	8
6 Test report.....	8
Bibliography.....	9

iTeh STANDARD PREVIEW
(standards.iteh.ai)

SIST EN ISO 13846:2001
https://standards.iteh.ai/catalog/standards/sist/c9774b06-5d06-4094-bc93-
ce2479a2975d/sist-en-iso-13846-2001

L'ISTITUTO ITALIANO DI STANDARDIZZAZIONE
 (UNI) È UN'ENTITÀ PUBBLICA CHE OPERA IN TUTTO IL MONDO PER PROMUOVERE
 E SVILUPPARE LE ATTIVITÀ DI STANDARDIZZAZIONE
 E DI CERTIFICAZIONE.

Foreword

The text of EN ISO 13846:2000 has been prepared by Technical Committee CEN/TC 155 "Plastics piping systems and ducting systems", the secretariat of which is held by NNI, in collaboration with Technical Committee ISO/TC 138 "Plastics pipes, fittings and valves for the transport of fluids".

This European Standard shall be given the status of a national standard, either by publication of an identical text or by endorsement, at the latest by April 2001, and conflicting national standards shall be withdrawn at the latest by April 2001.

According to the CEN/CENELEC Internal Regulations, the national standards organizations of the following countries are bound to implement this European Standard: Austria, Belgium, Czech Republic, Denmark, Finland, France, Germany, Greece, Iceland, Ireland, Italy, Luxembourg, Netherlands, Norway, Portugal, Spain, Sweden, Switzerland and the United Kingdom.

The material-dependent parameters and/or performance requirements are incorporated in the System Standard(s) concerned.

This standard is one of a series of standards on test methods which support System Standards for plastics piping systems and ducting systems.

iTeh STANDARD PREVIEW (standards.iteh.ai)

[SIST EN ISO 13846:2001](https://standards.iteh.ai/catalog/standards/sist/d97afb68-5d96-4094-bc93-ce2479a2975d/sist-en-iso-13846-2001)

<https://standards.iteh.ai/catalog/standards/sist/d97afb68-5d96-4094-bc93-ce2479a2975d/sist-en-iso-13846-2001>

1 Scope

This standard specifies a test method for the long-term leaktightness of end-load-bearing and non-end-load-bearing mechanically jointed assemblies and joints between fittings, ancillaries, valves and thermoplastics pressure pipes, including integral pipe joints.

This method is applicable to joints where similar or different materials are connected, where sealing mechanisms include elastomeric sealing rings or adhesives.

This method is applicable in addition to the hydrostatic pressure tests for materials and components.

2 Principle

The test simulates expansion of the joint area due to creep. This is related to the permissible working conditions for 50 years and based on the properties of the components assembled.

The leaktightness of the joint(s) is tested as an assembly comprising either:

- a) at least one fitting joined to pipes; or
- b) an ancillary component or a valve joined to pipes; or
- c) a pipe-to-pipe joint.

The test is carried out for at least 1000 h at ambient temperature and at the maximum allowed working temperature for the piping system for which the assembly or joint is intended to be used.

The test piece and its joint(s) are subjected to a specified internal hydrostatic water pressure at a specified temperature for the period of time (1000 h or more) specified in the referring standard. Additional reinforcement of the joint area is not permitted for this test.

NOTE It is assumed that the following test parameters are set by the standard making reference to this standard:

- a) the minimum test period under pressure, i.e. 1000 h or more (see clause 2 and 5.4);
- b) the free length, L , of the pipe sections under test (see 4.1);
- c) the number of test pieces (see 4.2);
- d) the test temperature (e.g. ambient or maximum allowed working temperature) (see 5.2);
- e) the test pressure (see 5.3).

3 Apparatus

3.1 Ambient temperatures

For tests at ambient temperatures (see 5.2), a test room or water bath, capable of being maintained at a temperature to within $\pm 2^\circ\text{C}$.

3.2 Elevated temperatures

For tests at elevated temperatures, an air chamber or water bath, capable of being maintained at the specified test temperature to within $\begin{pmatrix} +3 \\ -1 \end{pmatrix}^\circ\text{C}$.

3.3 Pressure control device

A pressure control device connected to the test assembly and capable of applying a constant hydrostatic pressure to within $\begin{pmatrix} +2 \\ -1 \end{pmatrix}\%$.

3.4 Support

Support for end-load-bearing assemblies and joints such that the assemblies and joints shall be subjected to the axial forces generated during the test and such that the support shall not provide any axial restraint. (For bibliography see EN 715^[1].) An example of solvent cement type test assembly is shown in figure 1.

3.5 Compensating device

A compensating device for non-end-load-bearing assemblies and joints, capable of sustaining the axial forces generated by the internal water pressure, whilst maintaining the axial alignment of the joint assembly. (For bibliography see EN 714^[2].) Connecting rods or external frames between non-end-load-bearing bearing sealing devices to keep them in place as necessary to prevent any separation. Examples of test assemblies are shown in figures 2 and 3.

NOTE Precautions can be necessary to maintain the alignment of the joint assemblies, particularly for removal of the test assemblies from the test bath.

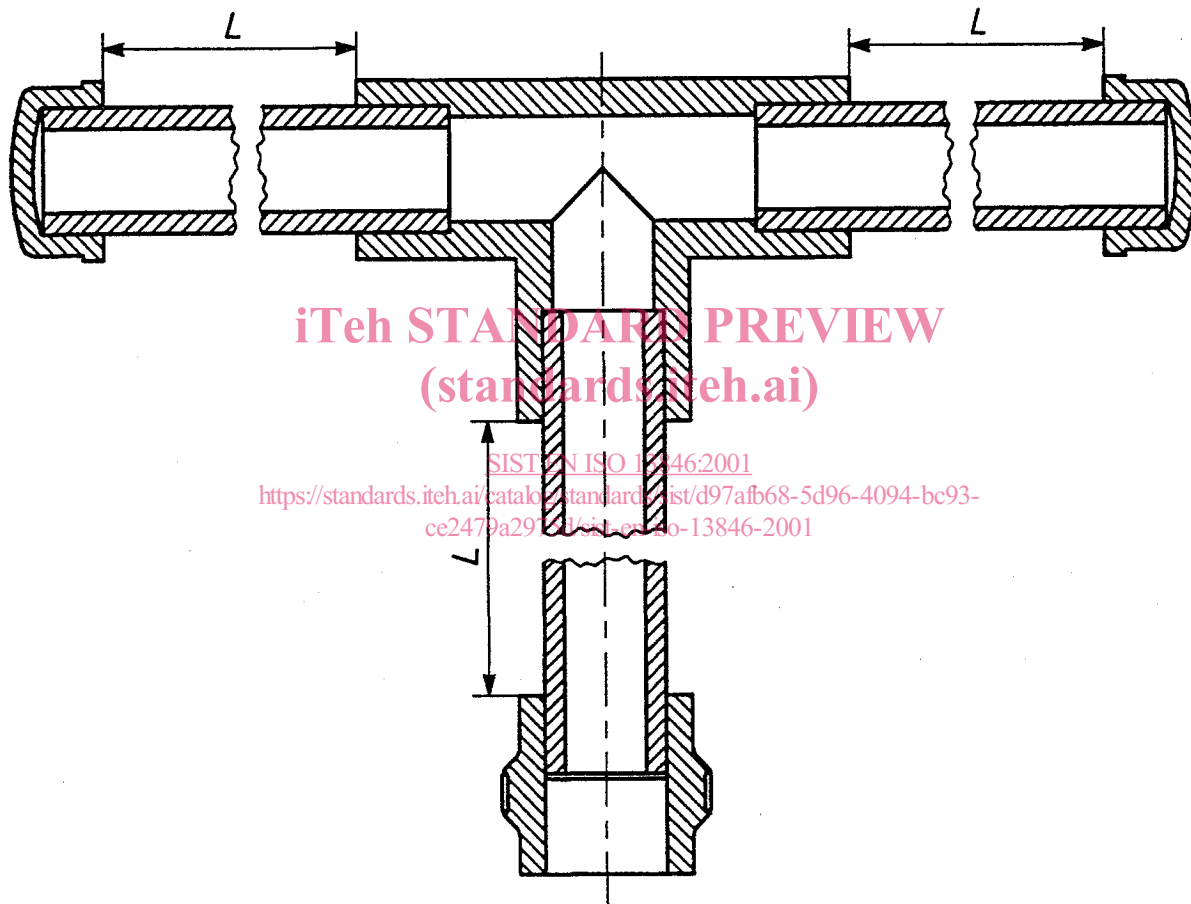

Figure 1 — Example of solvent cement type test assembly

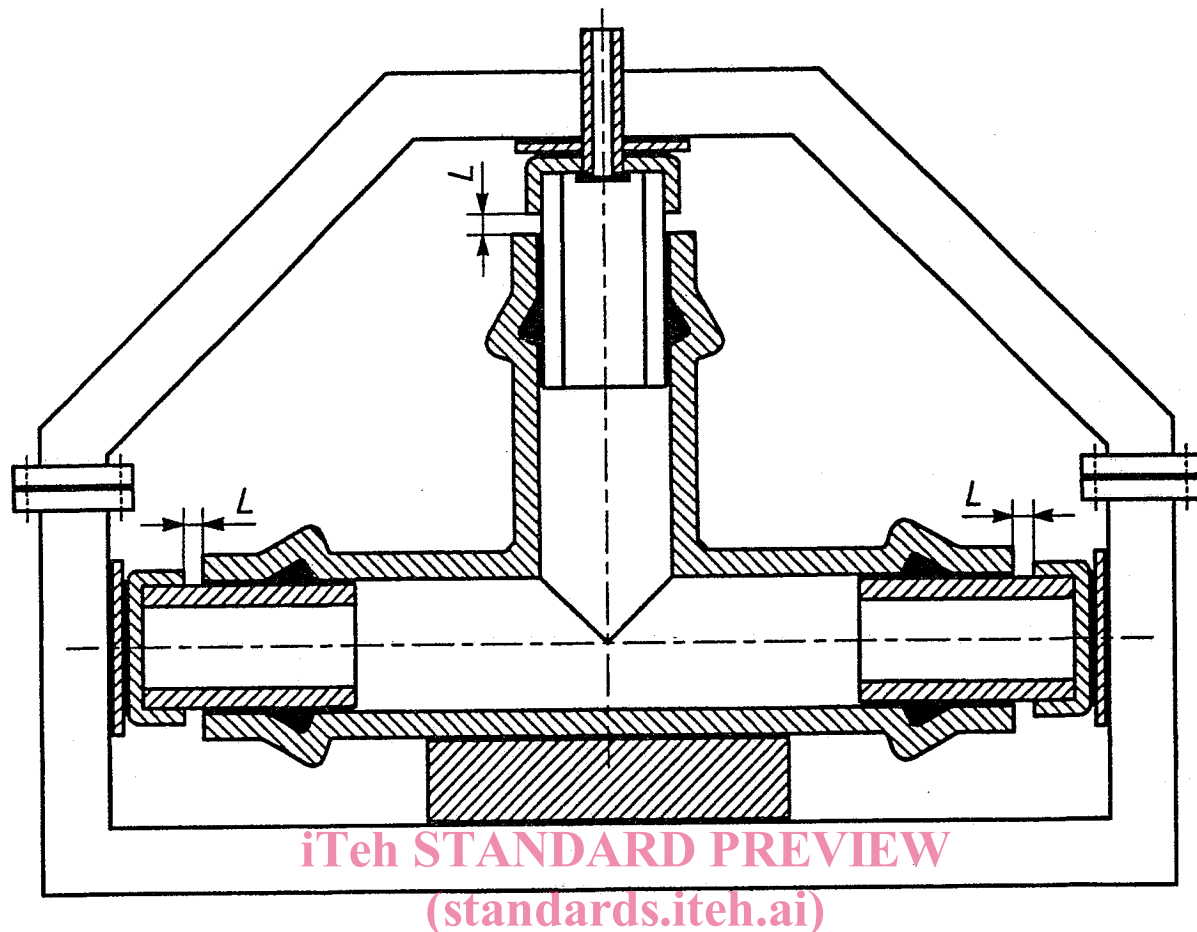

Figure 2 — Example of elastomeric sealing ring type test assembly

[SIST EN ISO 13846:2001](https://standards.iteh.ai/catalog/standards/sist/d97afb68-5d96-4094-bc93-ce2479a2975d/sist-en-iso-13846-2001)

<https://standards.iteh.ai/catalog/standards/sist/d97afb68-5d96-4094-bc93-ce2479a2975d/sist-en-iso-13846-2001>

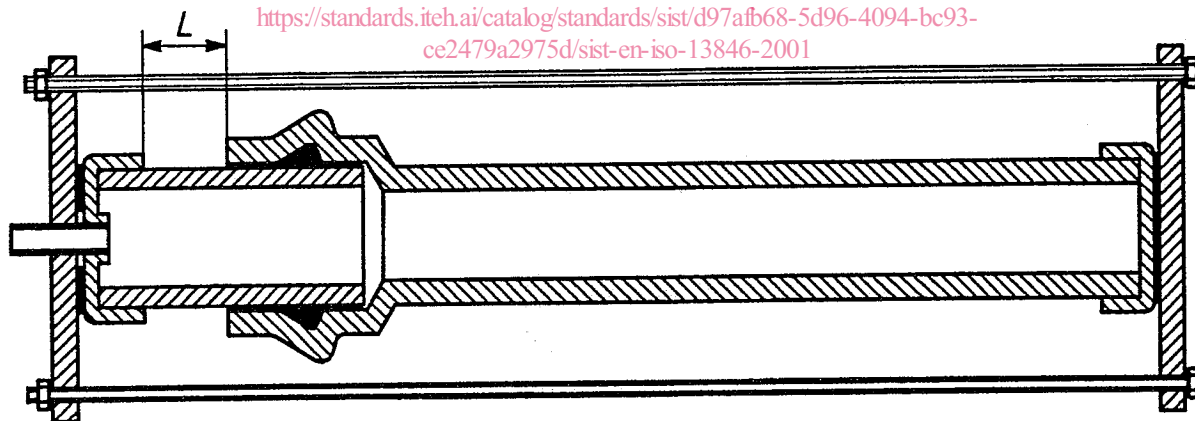

Figure 3 — Example of integral joint type test assembly

4 Test piece

4.1 Preparation

The test piece shall comprise an assembly containing at least one pipe sample joined to a socket of a fitting or to a socketed pipe or joined with an assembled finished product (such as a valve or union). Additional components may be added to the test assembly as required.

Components of the same nominal pressure, PN, or the same pipe series S, shall be used for the assembly.

The relevant dimensions of the joint components shall be measured and recorded, i.e. the mean outside diameter and out-of-roundness of any spigot or pipe joint area, the mean inside diameter and out-of-roundness of any socket and the relevant dimensions of any intermediate component (see note at the end of this clause).

The minimum length of the pipe section shall be such that its free length, L , between the assembly under test and the joint or the end closure (plug or cap) shall be as specified in the referring standard.

NOTE If the free length is not specified in the referring standard, it should be not less than the nominal outside diameter of the pipe, with a minimum of 150 mm.

All components shall conform to the appropriate part of the applicable System Standard. In addition the elastomeric sealing rings shall conform to the manufacturer's specifications.

The assembly shall be carried out in accordance with the manufacturer's instructions.

For non-end-load-bearing joints connecting rods or external frames may be used as necessary to prevent any separation (see 3.5).

NOTE For this test components should be selected which are as near as possible to the extremes of their respective tolerance bands which provide the most severe test conditions, e.g. for elastomeric sealing ring joints the socket and the diameter of the ring groove housing should be at or as near as possible to their maximum value, the spigot of the pipe or fitting should be at or as near as possible to the minimum value, and the sealing ring should be at or as near as possible to the minimum cross-section specified by the manufacturer.

4.2 Number

The number of test piece components and/or joints tested shall be as specified in the referring standard.

iTeh STANDARD PREVIEW (standards.iteh.ai)

5 Procedure

WARNING All necessary precautions should be taken when testing using components under pressure.

[SIST EN ISO 13846:2001](https://standards.iteh.ai/catalog/standards/sist/d97afb68-5d96-4094-bc93-ce2479a2975d/sist-en-iso-13846-2001)

5.1 Preparation <https://standards.iteh.ai/catalog/standards/sist/d97afb68-5d96-4094-bc93-ce2479a2975d/sist-en-iso-13846-2001>

Fill the test assembly with water. Set up the test assembly, without any deformation, in the apparatus appropriate to the type of joint and adjust the pipe section(s) in line with the axis (axes) of the socket(s).

5.2 Conditioning

Condition the test assembly in the test room or conditioning chamber for at least 3 h for test temperatures more than 25 °C or for at least 20 min for test temperatures equal to or less than 25 °C. If the test temperature is specified as "ambient temperature", carry out the conditioning at any temperature between 15 °C and 25 °C. During subsequent testing in accordance with 5.3 to 5.5 inclusive, maintain the test temperature constant to within ± 2 °C and within the range of 15 °C to 25 °C.

5.3 Pressure control

Connect the test assembly to the pressure control device. Evacuate all air from the test assembly and within the period 30 s to 1 min apply the test pressure as specified in the referring standard.

Record the time when the test pressure is achieved as the commencement of the test period.

Inspect the assembly for any signs of leakage and report the result.

5.4 Examination of the test assembly

When required (see 5.5), inspect the test assembly, as appropriate, as follows.

- a) If the test is carried out in air, thoroughly dry the whole outside surface of the test piece and examine it for leakage.