



## Standard Test Method for Frost/Dew Point of Sealed Insulating Glass Units<sup>1</sup>

This standard is issued under the fixed designation E 546; the number immediately following the designation indicates the year of original adoption or, in the case of revision, the year of last revision. A number in parentheses indicates the year of last reapproval. A superscript epsilon ( $\epsilon$ ) indicates an editorial change since the last revision or reapproval.

*This standard has been approved for use by agencies of the Department of Defense.*

<sup>ε1</sup>Note—Keywords were added in October 1999.

### 1. Scope

1.1 This test method describes a laboratory procedure for determining the frost/dew point within the air space(s) of sealed insulating glass units, and establishes the criteria for determining whether that point is below or above a given or specified temperature.

1.2 This test method also describes the apparatus to be used for these determinations.

1.3 The values stated in SI units are to be regarded as the standard. The values given in parentheses are for information only.

1.4 *This standard does not purport to address all of the safety concerns, if any, associated with its use. It is the responsibility of the user of this standard to establish appropriate safety and health practices and determine the applicability of regulatory limitations prior to use. For specific hazard statements, see Notes 2 and X1.1. For specific hazard statements, see 9.1.3.*

### 2. Referenced Documents

2.1 *ASTM Standards:*<sup>2</sup>

C 1036 Specification for Flat Glass

E 77 Test Method for Inspection and Verification of Thermometers

~~E 576 Test Method for Frost Point of Sealed Insulating Glass Units in Vertical Position~~ Test Method for Frost/Dew Point of Sealed Insulating Glass Units in the Vertical Position

E 631 Terminology of Building Constructions

### 3. Terminology

3.1 ~~frost point~~—the temperature at which visible frost begins to deposit on the lower air space glass surface of a sealed insulating glass unit in contact with the measuring surface of the frost point apparatus. Definitions—For definitions of general terms used in this test method, refer to Terminology E 631.

3.2 ~~frost state~~—the case where the frost point of a sealed insulating glass unit is above the test temperature specified by the purchaser or user.

3.3 ~~no-frost state~~—the case where the frost point of a sealed insulating glass unit is below the temperature specified by the purchaser or user. Definitions of Terms Specific to This Standard:

3.2.1 ~~frost state~~—the case where the frost/dew point of a sealed insulating glass unit is above the test temperature specified by the purchaser or user.

3.2.2 ~~frost/dew point, n~~—the temperature at which water, organic vapor, or other chemicals begin to appear on the interior glass surface of a sealed insulating glass unit in contact with the measuring surface of the frost/dew-point apparatus.

3.2.3 ~~no-frost state~~—the case where the frost/dew point of a sealed insulating glass unit is below the temperature specified by the purchaser or user.

### 4. Summary of Test Method

4.1 This test method is conducted by the use of a special apparatus, consisting basically of two chilled cylindrical metal blocks positioned one over the other and separated by a gap of controllable distance. The upper block has an exposed flat circular surface, 25 mm (1 in.) in diameter, and can be chilled to far below the ice point by regulating the air-gap distance between it and the lower

<sup>1</sup> This test method is under the jurisdiction of ASTM Committee E-6/E06 on Performance of Buildings and is the direct responsibility of Subcommittee E06.22 on Durability Performance of Building Constructions.

Current edition approved March 25, 1988; April 1, 2008. Published September 1988; May 2008. Originally published as E546-75; approved in 1975. Last previous edition approved in 1999 as E 546 – 838 (1999) <sup>ε1</sup>.

<sup>2</sup> For referenced ASTM standards, visit the ASTM website, [www.astm.org](http://www.astm.org), or contact ASTM Customer Service at [service@astm.org](mailto:service@astm.org). For *Annual Book of ASTM Standards* Volume 15.02, volume information, refer to the standard's Document Summary page on the ASTM website.

metal block which is maintained at approximately  $-78^{\circ}\text{C}$  ( $-109^{\circ}\text{F}$ ) by dry ice. The test specimen is placed in contact with this chilled flat circular surface of the upper block for specified short periods of time, with the metal surface at successively lower temperatures, to determine at what temperature frost appears on the corresponding lower air space glass surface.

## 5. Significance and Use

5.1 This test method and the apparatus described are intended primarily for sealed insulating glass units positioned horizontally. If the procedure is applied to such units in other than a horizontal position, the results may not be comparable to those obtained by this procedure.

NOTE 1—A similar method is Test Method E 576.

## 6. Apparatus

6.1 *Test Apparatus*<sup>3</sup> (see Fig. 1), consisting of upper and lower cylindrical metal blocks; blocks with a thermocouple, bimetallic thermometer, or other suitable temperature sensors being inserted in the upper block; a control ring; and an insulated containment cylinder fitted with a retainer spring assembly. The two metal blocks are separated by a small air gap, the distance of which can be regulated by the control ring. The exposed flat circular surface of the upper block is 25 mm (1 in.) in diameter; diameter; has a ground or lapped finish; and, when placed in contact with the glass test specimen, forms the frost/dew point measuring surface. The lower block is chilled by a dry ice pack kept in contact with it by the retainer spring assembly, maintaining it at a temperature near to that of sublimating dry ice ( $-78^{\circ}\text{C}$  ( $-109^{\circ}\text{F}$ )). Because the solid metal blocks are highly conductive, the temperature of each is virtually uniform. Use of the control ring adjusts the air gap distance between the two blocks to give the desired thermal resistance across the air gap. The circular measuring surface of the upper block is thus readily adjusted to the desired temperature while in contact with the test specimen. The circular measuring surface diameter specified is suitable for frost/dew point measurement of glass up to 6.0 mm ( $\frac{1}{4}$  in.) thick.

6.1.1 *Upper and Lower Metal Blocks*, aluminum alloy that may be anodized, conforming to the dimensions shown in Fig. 1. Other parts of the apparatus may be fabricated from any appropriate materials.

6.1.2 *Calibrated Temperature-Measuring Device*; such as a thermocouple, thermistor, or bimetallic thermometer; having a suitable range graduated in  $1^{\circ}\text{C}$  ( $2^{\circ}\text{F}$ ) or smaller units; units; and an accuracy of  $\pm 0.5^{\circ}\text{C}$  ( $\pm 1^{\circ}\text{F}$ ) over the full scale. A suggested calibration of the bimetallic thermometer is described in Appendix X1.

## 7. Test Specimen

7.1 The specimen to be tested shall be representative of the units to be evaluated and capable of being positioned horizontally.

## 8. Conditioning

8.1 Prior to testing, condition the test specimen at a temperature of  $24 \pm 3^{\circ}\text{C}$  ( $75 \pm 5^{\circ}\text{F}$ ) for not less than 24 h.

## 9. Procedure

### 9.1 Preparation of Apparatus:

9.1.1 Disassemble the apparatus by taking out the dry ice container and retainer spring assembly. Carefully clean the measuring surface with a soft cloth or paper. Do not scratch the measuring surface. Wipe and clean the apparatus thoroughly if any moisture is condensed on the surfaces and walls.

9.1.2 Assemble the dry ice container and turn the control ring so that the air gap distance between upper and lower metal blocks is about 13 mm (0.5 in.). Invert the apparatus onto a soft cloth.

9.1.3 Spray alcohol or acetone (~~Warning—See Note 2)~~ **Warning—Both alcohol and acetone are flammable.**) on the fin of the dry ice container to ensure good contact with the dry ice. Compactly charge the container with the crushed or pulverized dry ice up to the “full”<sup>2,2</sup> “full” mark. Compress the dry ice with the spring assembly and lock the cover lid.

NOTE 2—**Warning:** Both alcohol and acetone are flammable.

9.1.4 Return the apparatus to an upright position and secure it onto a horizontal surface. Allow sufficient time for the temperature of the lower metal block to approach that of the dry ice temperature.

### 9.2 Recharging of Apparatus:

9.2.1 During the test procedure, replenish the supply of dry ice whenever it becomes depleted by turning the apparatus upside down on a soft cloth, opening the cover lid, taking out the retainer spring assembly, and repeating steps 9.1.3 and 9.1.4.

### 9.3 Determination of Frost State and No-Frost State:

9.3.1 Charge the frost/dew point apparatus with dry ice as described in 9.1 or 9.2.

<sup>3</sup>Annual Book of ASTM Standards, Vol 14.05.

<sup>3</sup>The sole source of supply of the apparatus known to the committee at this time is Dennis Industries, 20032 Waynegarden Court, Germantown, MD 20874, <http://www.dennisind.com>. If you are aware of alternative suppliers, please provide this information to ASTM International Headquarters. Your comments will receive careful consideration at a meeting of the responsible technical committee, which you may attend.

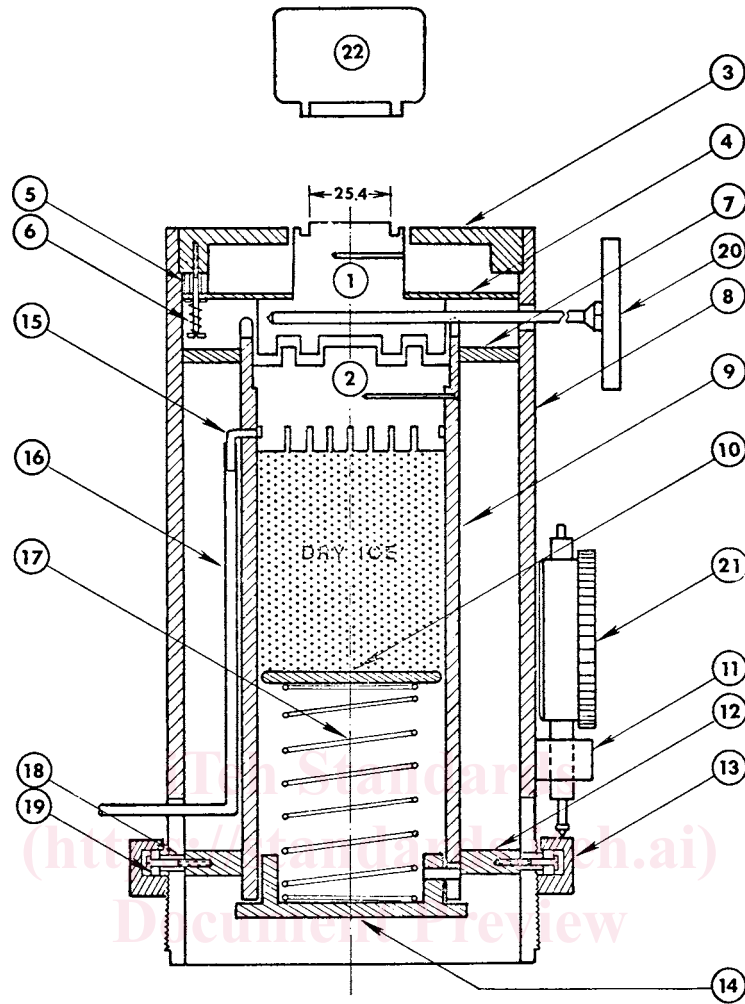

Parts List

Part No.	Nomenclature	Part No.	Nomenclature
1	upper metal block	12	supporting ring, bottom of inner tube
2	lower metal block	13	control ring
3	top cover	14	cover lid, inner tube
4	supporting plate, upper metal block	15	elbow
5	spacer	16	tube, nylon
6	spring, upper metal block	17	main spring
7	supporting plate, top of inner tube	18	spacer
8	outer tube	19	bearing
9	inner tube	20	bimetallic dial thermometer
10	disk, dry ice pushing	21	dial indicator
11	clamp, dial gage	22	heat source block

FIG. 1 Schematic Diagram of Frost/Dew-Point Apparatus

9.3.2 Clean both exterior surfaces of the specimen.

9.3.3 Place a piece of silver-colored aluminumized polyester film<sup>3</sup> (highly reflective mirror surface, not thicker than 0.08 mm (0.003 in.) and 25 mm (1 in.) in diameter or 25 by 25 mm (1 by 1 in.) on the measuring surface by wetting both surfaces of the film with acetone or alcohol (**Warning—See Warning—See Note 29.1.3**). Center the specimen on the apparatus. Examine the lower air space glass surface in the region where frost is to be deposited, to be aware of any dirt or other foreign particles that might be mistaken for frost. Note, however, that a small foreign particle on the lower air space glass surface may be helpful in focusing on the surface where the frost is to be deposited (see Fig. 2).

9.3.4 Slowly reduce the air gap distance between upper and lower metal blocks by turning the control ring while watching the temperature of the upper metal block.

9.3.5 Bring the temperature of the upper metal block to the temperature to be checked for frost and stabilize it by fine adjustment of the control ring. Temperature fluctuation should not exceed  $\pm 1^{\circ}\text{C}$  ( $2^{\circ}\text{F}$ ).

9.3.6 Maintain the stabilized temperature for a duration as follows: