



Designation: E1754 – 08

Standard Test Method for Determination of Low Levels of Water in Liquid Chlorine By Infrared Spectrophotometry¹

This standard is issued under the fixed designation E1754; the number immediately following the designation indicates the year of original adoption or, in the case of revision, the year of last revision. A number in parentheses indicates the year of last reapproval. A superscript epsilon (ϵ) indicates an editorial change since the last revision or reapproval.

1. Scope*

1.1 This test method covers the determination of the content of water in liquid chlorine in the concentration range of 0.5 to 15 mg/kg (ppm).

1.2 The values stated in SI units are to be regarded as standard. The values given in parentheses are for information only.

1.3 *This standard does not purport to address all of the safety concerns, if any, associated with its use. It is the responsibility of the user of this standard to establish appropriate safety and health practices and determine the applicability of regulatory limitations prior to use. See Section 7 for specific hazards statements.*

1.4 Review the current Material Safety Data Sheets (MSDS) for detailed information concerning toxicity, first aid procedures, and safety precautions.

2. Referenced Documents

2.1 *ASTM Standards:*²

D1193 Specification for Reagent Water

E806 Test Method for Carbon Tetrachloride and Chloroform in Liquid Chlorine by Direct Injection (Gas Chromatographic Procedure)

2.2 *Federal Standards:*³

49 CFR 173 Code of Federal Regulations Title 49 Transportation: Shippers' General Requirements for Shipments and Packaging, including Sections:

173.304 Charging of Cylinders with Liquefied Compressed Gas

173.314 Requirements for Compressed Gases in Tank Cars

173.315 Compressed Gases in Cargo Tanks and Portable Tank Containers

3. Summary of Test Method

3.1 A sample of liquid chlorine is introduced into a special infrared cell and maintained as a liquid under its own pressure. A spectrometer scans from 400 to 4400 wavenumbers of the infrared transmission spectrum of liquid chlorine. This spectrum is then ratioed to one obtained of the nitrogen-filled infrared cell previously. The ratioed spectrum is converted to absorbance, and the net absorbance of the water band at 1596 wavenumbers, relative to a reference at 1663 wavenumbers, is determined. The amount of water corresponding to this net absorbance is determined from a calibration curve prepared from the infrared absorbances of standards that contain known concentrations of water in liquid chlorine.

4. Significance and Use

4.1 Trace amounts of water may be detrimental to the use of chlorine in some applications. The amount of water in the chlorine must be known to prevent problems during its use.

5. Apparatus

5.1 *Infrared Spectrometer*, capable of measurements in the 1600 wavenumber region. An FTIR with 4 wavenumber resolution is the instrument of choice, but dispersive instruments may also be used to achieve similar results.

5.2 *Special Infrared Cell* (see Fig. 1), neither cell size nor pathlength are critical to the analysis, but sensitivity and limit of detection are dependent on pathlength. The concentration range reported in the scope is achievable with a 60-mm pathlength cell constructed with:

5.2.1 *Hastelloy C and 316 Stainless Steel Stock*, suitable for machining.

5.2.2 *Silver Chloride Windows*, 0.5 by 2.5 cm.

¹ This test method is under the jurisdiction of ASTM Committee D16 on Aromatic Hydrocarbons and Related Chemicals and is the direct responsibility of Subcommittee D16.16 on Industrial and Specialty Product Standards.

Current edition approved April 1, 2008. Published May 2008. Originally approved in 1995. Last previous edition approved in 2001 as E1754– 95 (2001) ^{ϵ 1}. DOI: 10.1520/E1754-08.

² For referenced ASTM standards, visit the ASTM website, www.astm.org, or contact ASTM Customer Service at service@astm.org. For *Annual Book of ASTM Standards* volume information, refer to the standard's Document Summary page on the ASTM website.

³ Available from Superintendent of Documents, Government Printing Office, Washington, DC 20402.

*A Summary of Changes section appears at the end of this standard

1/8" x 1/4"
material: Hastalloy C
2 required

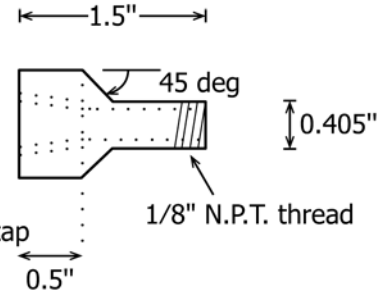
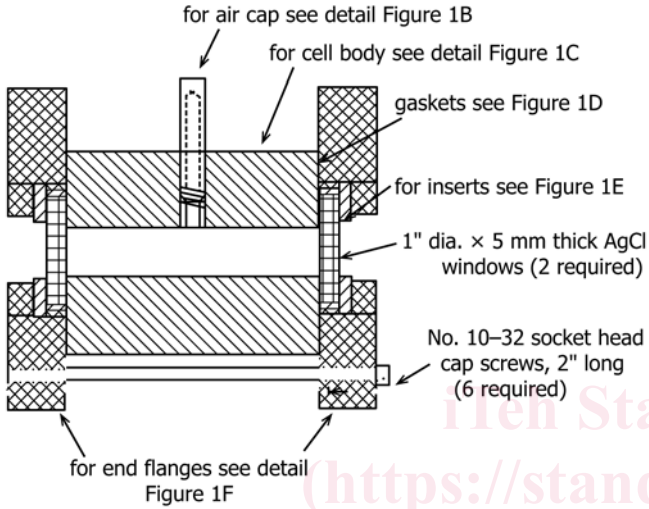
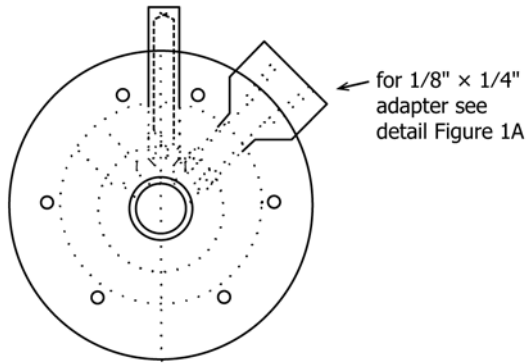
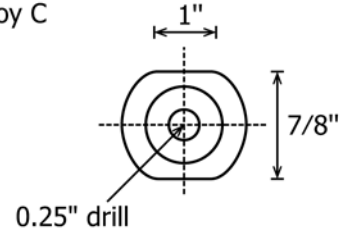

if desired, pipe adapters may be welded

FIG. 1(a) Pipe Adapter

NOTE 1—Drawing not to scale.

FIG. 1 Infrared Cell

iteh Standards
(<https://standards.iteh.ai>)
Document Preview

ASTM E1754-08

<https://standards.iteh.ai/catalog/standards/sist/9f0523e6-b7fe-4c7a-9d10-1119b80e84b9/astm-e1754-08>

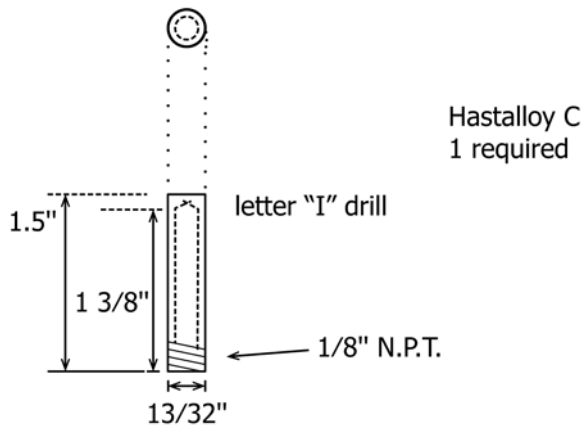

FIG. 1(b) Air Cap Detail

Letter "R" drill 7/16" deep

Letter "I" drill thru
1/8" N.P.T. tap

3 holes as shown

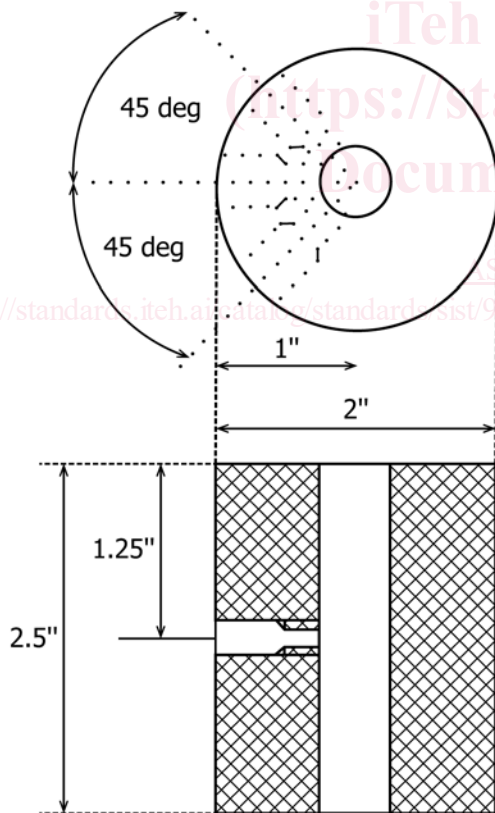
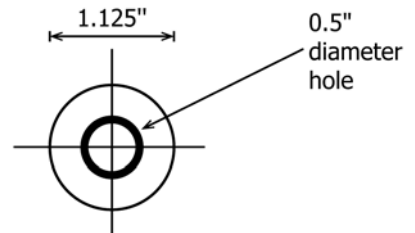

FIG. 1(c) Body Detail



DuPont Kalrez Perfluoroelastomer
2 required
material about 0.030" thick

FIG. 1(d) Gasket Detail

Material: Teflon
2 required

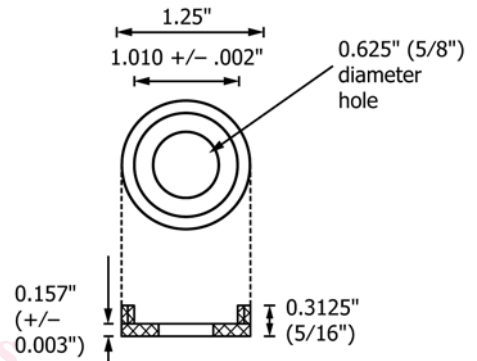

FIG. 1(e) Insert Detail

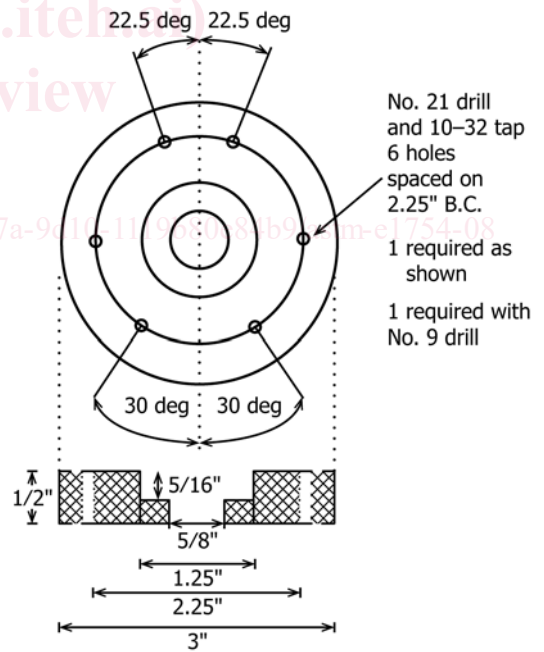

FIG. 1(f) Flange Detail

5.2.3 *Perfluoroelastomer Sheet*, 0.030 in. thickness.

5.3 *Ball Valves*, Monel ¼ in. valve with pipe and ¼ in. tube ends.

5.4 *Needle Valves*, nickel or Monel 6.35 mm (¼ in.) valve with pipe and 6.35 mm (¼ in.) tube ends.

5.5 *Sample Cylinder Assembly* (see Fig. 2), consisting of:

5.5.1 *Sample Cylinder*, nickel, Monel, or tantalum; 400 to 1000 mL capacity, double-ended, with valves at each end, specially cleaned. Cylinders with both valves at one end and with a dip tube on one valve have been found to be satisfactory. Another option is to construct special cylinders containing a septum fitting on one end.

NOTE 1—A procedure for cleaning cylinders and valves, for use with liquid chlorine, is given in Test Method E806, Appendix X2.

5.5.2 *Needle and Ball Valve*, nickel body, having packing resistant to liquid chlorine. If nickel valves are not available, Monel valves may be used.

5.5.3 *Septum*, inserted into a 6.35 mm (¼ in.) nut.

5.5.4 *Glove Bag or Dry Box*, purged with dry nitrogen (less than 5 ppm water vapor).

5.5.5 *Fittings*, for transferring chlorine from one cylinder to another.

5.5.6 *0 to 10- µL Syringe and 0 to 25-µL Syringe*, 26-gage needle.

5.5.7 *Dewar Flask*, of sufficient size to hold a cylinder surrounded by dry ice and methylene chloride. The Dewar flask should be supported by a wooden holder for safety purposes.

5.5.8 *Hygrometer*, capable of measuring moisture as low as 5 mg/kg (ppm) in glove bag or dry box.

5.6 *Silicone Rubber Septa*.

5.7 *Mechanical Shaker*.

5.8 *Drying Oven*.

6. Reagents

6.1 *Purity of Water*—See Specification D1193.

6.2 *Chlorine*, liquid with less than 5 mg/kg (ppm) water.

6.3 *Methylene Chloride* (CH_2Cl_2).

NOTE 2—This reagent is used for cooling purposes only.

6.4 *Dry Ice* (CO_2).

6.5 *Dry Nitrogen*, (<5 mg/kg (ppm) water) to purge glove bag or dry box and test equipment.

7. Hazards

7.1 Safety Precautions:

7.1.1 Chlorine is a corrosive and toxic material. A well-ventilated fume hood should be used to house all test equipment, except the infrared spectrophotometer, when this material is analyzed in the laboratory.

7.1.2 The analysis should be attempted only by persons who are thoroughly familiar with the handling of chlorine, and even an experienced person should not work alone. The analyst must be provided with adequate eye protection (chemical goggles are recommended) and an approved chlorine respirator. Splashes of liquid chlorine destroy clothing and if such clothing is next to the skin, will produce irritation and burns.

7.1.3 When sampling and working with chlorine out of doors, people downwind from such operations should be warned of the possible release of chlorine.

7.1.4 It is recommended that means be available for disposal of excess chlorine in an environmentally safe and acceptable manner. If chlorine cannot be disposed of in a chlorine consuming process, a chlorine absorption system should be provided. When the analysis and sampling regimen requires an initial purging of chlorine from a container, the purged chlorine should be similarly handled. Purging to the atmosphere should be avoided.

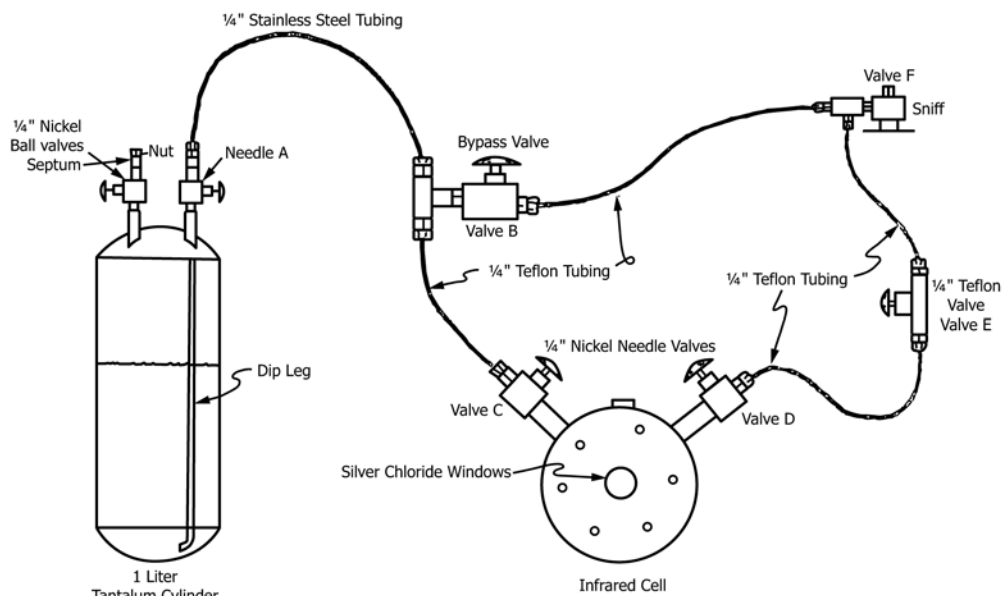

FIG. 2 Sample Cylinder Assembly