



Designation: B106 – 08

Standard Test Methods for Flexivity of Thermostat Metals¹

This standard is issued under the fixed designation B106; the number immediately following the designation indicates the year of original adoption or, in the case of revision, the year of last revision. A number in parentheses indicates the year of last reapproval. A superscript epsilon (ϵ) indicates an editorial change since the last revision or reapproval.

1. Scope

1.1 These test methods cover the determination of flexivity (a measure of thermal deflection rate or deflection temperature characteristics) of thermostat metals.

1.1.1 *Test Method A*—Tested in the form of flat strip 0.015 in. (0.38 mm) or over in thickness.

1.1.2 *Test Method B*—Tested in the form of spiral coils less than 0.012 in. in thickness.

1.2 The values stated in inch-pound units are to be regarded as standard. The values given in parentheses are mathematical conversions to SI units that are provided for information only and are not considered standard.

1.3 *This standard does not purport to address all of the safety concerns, if any, associated with its use. It is the responsibility of the user of this standard to become familiar with all hazards including those identified in the appropriate Material Safety Data Sheet (MSDS) for this product/material as provided by the manufacturer; to establish appropriate safety and health practices, and determine the applicability of regulatory limitations prior to use.*

2. Referenced Documents

2.1 *ASTM Standards*:² <http://www.astm.org/catalog/standards/sist/c4950e34-98e9-44d2-a77e-7c26bb43aad9/astm-b106-08>
B389 Test Method for Thermal Deflection Rate of Spiral and Helical Coils of Thermostat Metal

3. Terminology

3.1 *Definitions*:

3.1.1 *thermostat metal, n*—a composite material in the form of sheet or strip comprising two or more metallic layers of differing coefficients of thermal expansion, such that the radius of curvature of the composite changes with temperature change.

¹ These test methods are under the jurisdiction of ASTM Committee B02 on Nonferrous Metals and Alloys and are the direct responsibility of Subcommittee B02.10 on Thermostat Metals and Electrical Resistance Heating Materials.

Current edition approved April 1, 2008. Published May 2008. Originally approved in 1984. Last previous edition approved in 2002 as B106 – 96 (2002) ^{ϵ 1}. DOI: 10.1520/B0106-08.

² For referenced ASTM standards, visit the ASTM website, www.astm.org, or contact ASTM Customer Service at service@astm.org. For *Annual Book of ASTM Standards* volume information, refer to the standard's Document Summary page on the ASTM website.

3.1.2 *flexivity (F), n*—the change of curvature of the longitudinal center line of the specimen per unit temperature change for unit thickness, given by the following equation:

$$F = t \frac{(1/R_2) - (1/R_1)}{T_2 - T_1} \quad (1)$$

To determine the flexivity between any two temperatures, T_1 and T_2 , it is necessary to measure the curvature $1/R_1$ and $1/R_2$ at temperature T_1 and T_2 , respectively. To find the curvature at either temperature (Fig. 1 and Fig. 2), measure the distance D . The curvature is given by the following equation:

$$1/R = 8D/(Q^2 + 4Dt + 4D^2) \quad (2)$$

where:

R = radius of curvature of the longitudinal center line of the specimen, in. (mm),
 t = thickness of test specimen, in. (mm),
 Q = distance between support points, in. (mm), and
 D = for point support (simply supported beam), = perpendicular distance between the longitudinal center lines of the lower surface of the specimen midway between the point supports and the straight line joining the support points, in. (mm).

4. Significance and Use

4.1 These test methods are used for determining response to temperature change or flexivity of thermostat metal. The flexivity is calculated from the temperatures, dimensions of specimen, and the relative movement of the specimen. The simple beam method (Method A) is the method for certification. Any use of the spiral coil method (Method B) is to be mutually agreed upon between the user and supplier.

TEST METHOD A—FLAT STRIPS

5. Apparatus

5.1 *Specimen Carrier*, provided with two conical supports for locating the specimen. The test length (that is, the distance between the point of contact of the specimen with one support and the point of contact of the specimen with the other support) shall be known to within ± 0.005 in. (0.13 mm), and the line of plane passing through the points of contact shall be horizontal. The specimen carrier and supports shall hold the specimen without constraint so that the curvature, due to its deflection,

will follow a vertical plane passing through the line joining the

iTeh Standards
(<https://standards.itih.ai>)
Document Preview

[ASTM B106-08](#)

<https://standards.itih.ai/catalog/standards/sist/c4950e34-98e9-44d2-a77e-7c26bb43aad9/astm-b106-08>

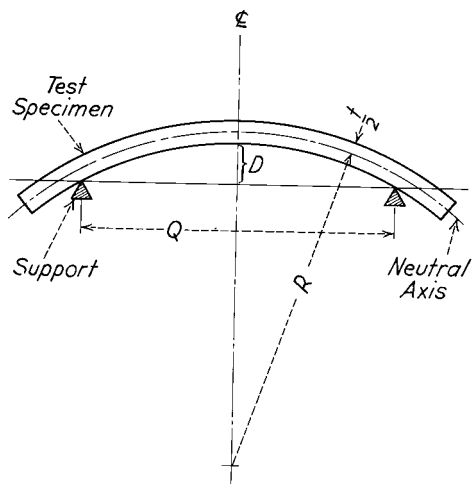

FIG. 1 Test for Flexivity of Thermostat Metals

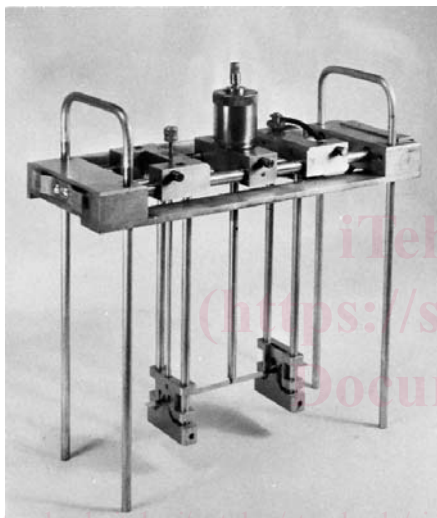

FIG. 2 Typical Apparatus Design

points of contact between specimen and supports. Suitable means shall be used to ensure test length.

5.2 *Micrometer*—traveling microscope, or equivalent device, so connected to the specimen carrier that expansion during heating of the carrier or connecting parts will not cause appreciable displacement of the measuring device with respect to the supports.

5.3 *Bath*—A stirred liquid bath or uniformly heated enclosure in which the specimen carrier, together with adjustable electric heating source is placed. The specimen needs to be maintained at the desired temperatures, with a variation in temperature throughout the gage length of the specimen not to exceed 0.5 % of the temperature range used in the test.

5.4 *Temperature Measuring Apparatus*, of such accuracy that the individual temperatures shall be known to within $\pm 0.5^\circ\text{F}$ (0.3°C).

5.5 *Deflection Index*—Means shall be provided for measuring the deflection of the specimen at a point midway between the points of support and along the vertical line intersecting the line joining the points of support. Such means may comprise a

transmission rod disposed with its axis vertical and terminating in a point or knife-edge, which shall engage the specimen midway between the points of contact with the supports.

5.5.1 The transmission rod shall be mounted in such a manner that it is free to move in the direction of its axis. The rod shall bear at its free end an index suitable for microscopical observation, or else an electrical contact with which a micrometer will permit the changes of the deflection of specimen to be accurately observed. Alternatively, the deflection of the midpoint of the specimen may be directly observed by optical means whose line of sight is horizontal and passes through the vertical line through the midpoint of the specimen. A micrometer screw with extended spindle making direct contact with the specimen may be used. In this case, electrical means shall be provided that will indicate contact without significant disturbance of the specimen. The measurement of the position of the midpoint of the test specimen shall be of such accuracy that the individual positions at the test temperatures shall be known to within ± 0.0002 in. (0.005 mm).

5.5.2 If a transmission rod is used, it and any attached parts shall be of such weight or so counterweighted that they will not cause a deflection greater than 1 % of the maximum to be produced by the action of the thermostat metal alone. When free, the thermostat metal assumed very nearly a circular curvature. Concentrated loading at the center of the specimen will cause the curvature to be other than circular and may cause significant errors in the evaluation of flexivity. The location of the line passing through the points of contact between specimen and supports shall be known, with reference to the scale of the micrometer, to within ± 0.002 in. (0.05 mm).

5.6 All metallic components of the flexivity apparatus should be made of very low coefficient of thermal expansion components. The recommended material is Invar.³

6. Test Specimens

6.1 The test specimen shall be in the form of a strip that displays no apparent initial irregularity of curvature.

6.2 The maximum thickness shall not be greater than the minimum thickness by more than 1 % of the latter.

6.3 The width shall be related to the thickness in accordance with Fig. 3. Preferred widths are to be used whenever possible. The maximum width shall not exceed the minimum width by more than 2 % of the latter.

6.4 The length shall be such as to allow a distance between supports that bears the relation to the thickness in accordance with Table 1 and to allow a distance beyond the supports not less than the width.

6.5 The thickness of the specimen shall be determined within ± 0.0001 in. (0.002 mm) by means of a screw micrometer or an equivalent method.

6.5.1 For specimens less than 0.050 in. (1.27 mm) in thickness, special precautions are necessary, such as the use of a micrometer reading directly to 0.0001 in. (0.002 mm). Suitable optical methods may also be used.

³ Invar is a registered trademark of CRS Holding, a subsidiary of Carpenter Technologies.

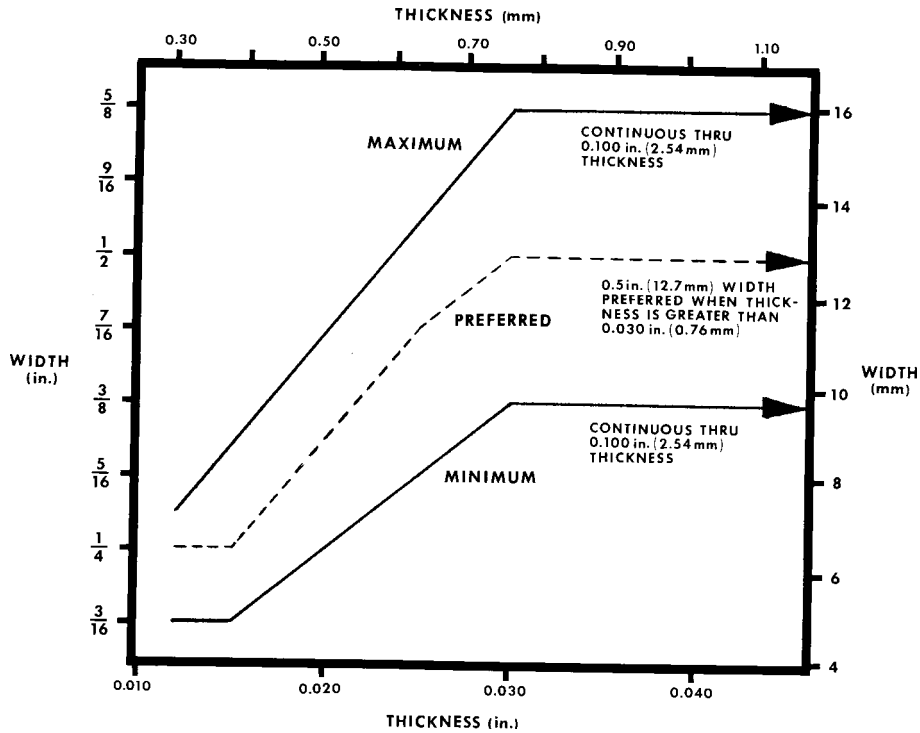

FIG. 3 Width of Test Specimen

TABLE 1 Gage Length of Test Specimen (Test Method A)

| Specimen Thickness | | Gage Length | |
|-----------------------|---------------------|-------------|--------------|
| in. | mm | in. | mm |
| 0.015 to 0.0199, incl | 0.38 to 0.509, incl | 2½ ± ½ | 63.5 ± 12.7 |
| 0.020 to 0.0249, incl | 0.51 to 0.639, incl | 3 ± ½ | 76.2 ± 12.7 |
| 0.025 to 0.0299, incl | 0.64 to 0.759, incl | 3½ ± ½ | 88.9 ± 12.7 |
| 0.030 to 0.0349, incl | 0.76 to 0.889, incl | 4 ± ½ | 101.6 ± 12.7 |
| 0.035 to 0.0449, incl | 0.89 to 1.139, incl | 4½ ± ½ | 114.3 ± 12.7 |
| 0.045 to 0.100, incl | 1.14 to 2.54, incl | 5 ± ½ | 127.0 ± 12.7 |

Remove the amount of material extending a distance not less than twice the thickness along each edge of the specimen, to eliminate material damaged by preliminary shaping. Slit edges with a minimum of burr may also be used.

7.2 When the specimen has been finished to size, make any necessary reference marks (by such means as a sharp drill, scribing tool, or milling cutter). Determine and record the relative locations of the reference marks. Do not use center punches or similar means because of the distortion produced.

7.3 It is recommended that the grain run along the length of the specimen.

8. Procedure

8.1 *Stabilization*—After all preparatory work has been completed, subject the test specimen to a stabilizing heat treatment to relieve internal stresses. This treatment may consist of heating the specimen, while free to bend, for a prescribed time and temperature. The details of the stabilizing procedure will depend upon the characteristics of the thermostat metal being tested and shall be as mutually agreed upon between the manufacturer and the purchaser.

8.2 *Test Routine*—Mount the specimen on the support on the specimen table. With the transmission rod in place take a zero reading at room temperature. Apply slight mechanical pressure and then remove the rod at a point near the center of the specimen. If appreciable zero shift is apparent with repeated applications of pressure, determine the cause and correct before proceeding with the test.

8.3 When satisfactory initial conditions have been established, make observations of deflection and temperature at low temperature and record the results.

6.5.2 The average thickness may be calculated from measurements of length, average width, weight, and density. When the density is unknown, it may be determined by weighing a sample of at least 10 g first in air and then in water. The density in grams per cubic centimetre is equivalent to the weight in air divided by the loss of weight due to submergence in water. The temperature of the water shall be approximately the same as that of the balance room to avoid errors due to convection currents. For the accuracy required, no corrections are necessary for the temperature of the water or for the buoyancy of the air. However, care shall be exercised to remove all air bubbles from the sample when weighing it in water and to avoid the presence of grease or other films on the surface of the water. To this end it is recommended that after a preliminary cleaning to remove obvious dirt, the sample be attached to a fine wire to be used later in suspending it while weighing and thoroughly rinsed, first in ether, then alcohol and finally water, before immersing in the water to be used for weighing.

7. Preparation of Test Specimen

7.1 After being roughly cut or sheared from the sample, finish the test specimen to size by careful machining or filing.