



Standard Test Methods for Equipment and Procedures Used in Evaluating the Performance Characteristics of Protective Headgear¹

This standard is issued under the fixed designation F 1446; the number immediately following the designation indicates the year of original adoption or, in the case of revision, the year of last revision. A number in parentheses indicates the year of last reapproval. A superscript epsilon (ϵ) indicates an editorial change since the last revision or reapproval.

Note—Section 14 and Appendix X2 were added editorially and the year date was changed on April 9, 2008.

INTRODUCTION

These test methods specify equipment and procedures used for testing protective headgear. Individual ASTM performance standards (standard specifications) will use these procedures and equipment. Test conditions, pass-fail criteria, and other performance requirements will be specified in the individual performance standards, tailored to the needs of a particular activity (for example, bicycling, skateboarding, skiing, etc.).

These test methods were developed using resources in medical, scientific, mechanical engineering, human factors, and biomechanical fields. However, it is recognized that it is not possible to write a protective headgear performance standard that will result in headgear that can protect against injury or death in all accidents. It is also recognized that serious injury or death can result from both low- and high-energy impacts, even when protective headgear is worn.

These test methods incorporate aspects of other recognized headgear performance standards. They draw from work done by others where appropriate for these test methods. These standards are referenced within this standard test method. It should be noted that these test methods specify laboratory tests of completed headgear to measure its ability to reduce head acceleration during use and other selected parameters.

1. Scope

1.1 These test methods cover laboratory equipment, procedures, and basic requirements pertinent to testing protective headgear. Deviations or additions, or both, to these test methods will be specified, as required, in individual ASTM performance standards.

1.2 *Requirements*—The protective headgear is to be tested under specified environmental conditions for the following:

1.2.1 Impact attenuation (the limiting of head acceleration) of the protective headgear, and

1.2.2 Strength and stability of the retention system and its attachment to the protective headgear.

1.2.3 Special tests for particular protective headgear uses will be specified in the individual performance standards to be used in conjunction with these test methods.

1.3 *This standard does not purport to address all of the safety concerns, if any, associated with its use. It is the responsibility of the user of this standard to establish appropriate safety and health practices and determine the applicability of regulatory limitations prior to use.*

2. Referenced Documents

2.1 ~~ASTM Standard:~~ ASTM Standard:²

E 177 Practice for Use of the Terms Precision and Bias in ASTM Test Methods

E 691 Practice for Conducting an Interlaboratory Study to Determine the Precision of a Test Method

F2220F 2220 Specification for Headforms

2.2 *Federal Motor Vehicle Safety Standard:*³

¹ These test methods are under the jurisdiction of ASTM Committee F08 on Sports Equipment and Facilities and are the direct responsibility of Subcommittee F08.53 on Headgear and Helmets.

Current edition approved Dec. 1, 2005. Published December 2005. Originally approved in 1993. Last previous edition approved in 2004 as F1446–04.

Current edition approved April 9, 2008. Published May 2008. Originally approved in 1993. Last previous edition approved in 2006 as F 1446 – 06.

² For referenced ASTM standards, visit the ASTM website, www.astm.org, or contact ASTM Customer Service at service@astm.org. For Annual Book of ASTM Standards volume information, refer to the standard's Document Summary page on the ASTM website.

³ Available from National Highway Traffic Safety Administration (NHTSA), 400 7th St., NW, Washington, DC 20590.

218 S7.1.8 Motorcycle Helmets

2.3 SAE Standard:⁴

SAE J211 Recommended Practice for Instrumentation for Impact Tests—Requirements for Channel Class 1000

3. Reference Table

3.1 For references to these test methods, the standard terms for reference are listed in bold type in Table 1 with the items to consider for each method. For conditions and anvils, use the standard term listed in Table 1. Referring to section numbers in these test methods is not the recommended method for reference.

4. Terminology

4.1 *basic plane, n*—an anatomical plane (Frankfort Horizontal Plane) that includes the superior rim of the external auditory meatus (upper edge of the external openings of the ear) and the inferior margin of the orbit (the lowest point of the floor of the eye socket). The headforms are marked with the basic plane (see Figs. 1 and 2).

4.2 *coronal plane, n*—an anatomical plane perpendicular to both the basic and midsagittal planes and passing through the superior rims of the right and left auditory meatuses. The transverse plane corresponds to the coronal plane (see Figs. 1 and 2).

4.3 *field of vision, n*—angle of vision as measured on the reference headform (upward, downward, and peripheral).

4.4 *headform size selection, n*—helmets shall be tested on the appropriate test headform size(s), as determined by the testing laboratory. Helmets shall be tested on the largest and smallest size test headforms on which they fit. If a smaller size of the same model fits the smaller headform, the larger helmet will be tested on the larger headform only. When multiple headform sizes are required, each test set of helmets will include at least one extent of coverage, vision test, retention test, and impact test on each specified headform size. “Fit” means that it is not physically difficult to put the helmet on the larger headform and that the helmet’s comfort or fit-foam is partially compressed on the smaller headform.

4.5 *helmet, n*—a protective device worn on the head in an effort to reduce or minimize injury to that portion of the head that is within an area above the test line (as defined in the individual performance standards).

4.6 *helmet position index (HPI), n*—the vertical distance from the brow of the helmet to the basic plane, when the helmet is placed on a reference headform. The manufacturer shall specify the size of the headform and the vertical distance.

4.7 *midsagittal plane, n*—an anatomical plane perpendicular to the basic plane and containing the midpoint of the line connecting the notches of the right and left inferior orbital ridges and the midpoint of the line connecting the superior rims of the right and left external auditory meatus. The longitudinal plane corresponds to the midsagittal plane (see Figs. 1 and 2).

4.8 *modular elastomer programmer (MEP), n*—a cylindrical-shaped pad used as the impact surface for the spherical impactor.

4.9 *preload ballast, n*—a “bean-bag” filled with shot placed on the helmet to secure its position on the headform. The weight of the preload ballast shall be 5.0 ± 0.1 kg unless otherwise specified in the individual performance specification.

4.10 *projection, n*—any part of a helmet, internal or external, that extends beyond the faired surface and is likely to cause injury.

4.11 *protective headgear, n*—see *helmet*.

<https://standards.iteh.ai/catalog/standards/sist/802faa48-75c2-4d90-8c8d-cfa627019025/astm-f1446-08>

⁴ Available from Society of Automotive Engineers (SAE), 400 Commonwealth Dr., Warrendale, PA 15096-0001.

TABLE 1 Table for Reference

Terms for Reference	Section	Items to Consider for Each Method
Chin Bar Rigidity	12.9	Types defined: impact velocity, nominal drop height
Conditioning Environments	10	Types defined: ambient, low temperature, high temperature, water immersion
Configuration	12.2	Standard requirement defined
Dynamic Retention Test	12.7.1	Types defined: mass of drop weight, drop height, extension pass/fail criteria
Headforms	7.1	Headforms to be used in all tests in Test Methods F 1446
Impact Anvil	7.3.1	Types defined: flat, hemispherical, cylindrical, triangular hazard, curbstone
Impact Attenuation Test	12.8	Types defined: number of impact sites, impact velocity and theoretical drop height, and maximum peak g value
Internal Projections	12.5.1	Standard requirement defined
Labeling	12.4	Standard labeling requirements defined
Materials	12.3	Standard requirement defined
Penetration Test	7.4	Types defined: drop height, striker weight, striker geometry, standard method of pass/fail defined
Peripheral Vision	12.6.1	Standard method of pass/fail for horizontal vision defined
Reference Marking	12.1	Standard method of marking defined, define test lines
Reporting	13	Standard report format defined
Roll-Off Test (Helmet Stability Test)	12.7.2	Types defined: mass of drop weight, drop height, standard method of pass/fail defined
Samples for Testing	8	Criteria to be considered in selecting number of samples
Selecting the Correct Headform	7.1.1	Method defined
Test Schedule	11	Standard test schedule defined

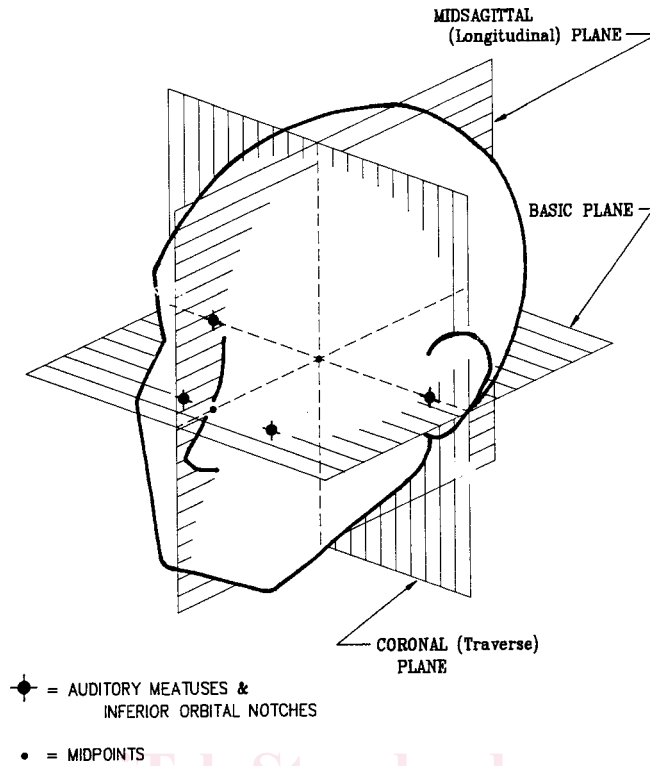

FIG. 1 Anatomical Planes

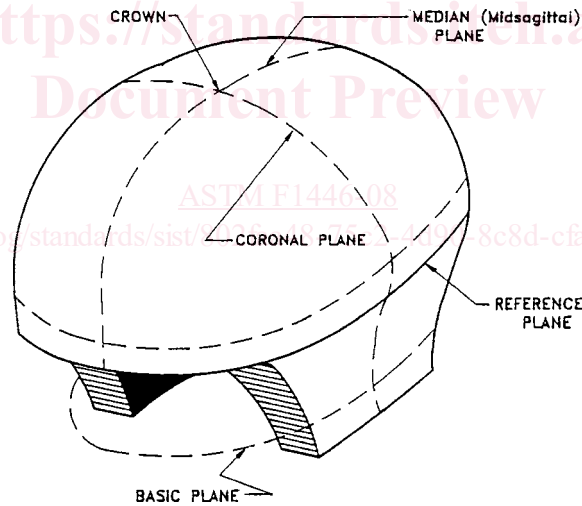

FIG. 2 Test Headform—Basic, Reference, and Midsagittal Planes

4.12 *reference headforms, n*—measuring headforms contoured in the same configuration as the test headforms sizes A, E, J, M, or O, as defined in Specification F 2220. The reference headforms should include surface markings corresponding to the basic, coronal, midsagittal, and reference planes (see Figs. 1 and 2).

4.13 *reference plane, n*—a plane marked on the headforms at a specified distance above and parallel to the basic plane (see Fig. 3).

4.14 *retention system, n*—the complete assembly that secures the helmet, in a stable position, on the wearer's head.

4.15 *shield, n*—optional equipment used in place of goggles to protect the eyes.

4.16 *spherical impactor, n*—a device made of low resonance material (for example, magnesium), aluminum alloy, or stainless steel that couples mechanically with the ball arm connector of the drop assembly in place of the impact test headform. When mounted, the device presents a spherically machined impact face with a radius of 73 mm on its bottom surface. All radii from the center of the curvature of the impact face to its outer edge shall from angles of no less than 40° with the downward vertical axis. The center of curvature shall be within 5 mm of the vertical axis drawn through the center of the ball arm. The mass and center of gravity of the drop assembly including the impactor shall meet the same requirements as those specified for the drop assembly incorporated with the test headforms (see 7.3.2).

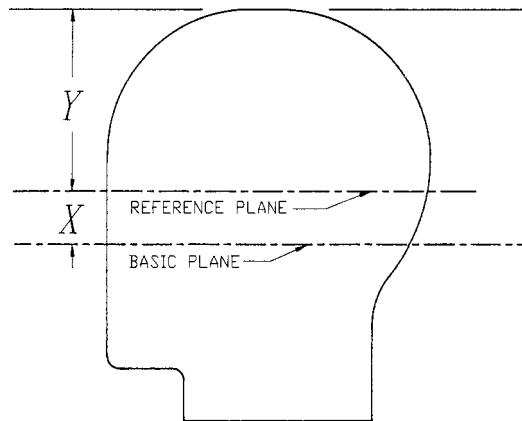

HEADFORM	SIZE, mm	X , mm	Y , mm
A	500	24	90
E	540	26	96
J	570	27.5	102.5
M	600	29	107
O	620	30	110

FIG. 3 Location of Reference Line

4.17 *test area, n*—the area of the helmet on or above a specified test line, subject to impact or penetration testing.

4.18 *test headforms, n*—test headforms that correspond to the physical dimensions defined in Specification F 2220 as sizes A, E, J, M, and O. The weight of the drop assembly including the headform shall be 5.0 kg unless otherwise specified in the individual performance specifications. The test headforms should include surface markings corresponding to the basic, coronal, midsagittal, and reference planes (see Fig. 2).

4.19 *test line, n*—a line drawn on the helmet as specified in the individual performance standards.

4.20 *visor (peak), n*—optional equipment for protection against sun or glare, and sometimes used as a rock or dirt deflector.

5. Significance and Use

5.1 The purpose of these test methods is to provide reliable and repeatable tests for the evaluation of various types of protective headgear. Use of these test methods in conjunction with the specific individual performance standards is intended to reduce the likelihood of serious injury and death resulting from impacts to the head sustained by individuals participating in sports, recreation, and other leisure activities in which protective headgear is worn.

6. Certification

6.1 These test methods permit self-certification. It is recommended that each manufacturer employ an independent test laboratory at least annually to test each model and size of protective headgear.

7. Apparatus

7.1 Test Headforms:

7.1.1 *General*—These test methods specify five headform sizes as identified in Specification F 2220 (A, E, J, M, and O) for performing reference measurements, impact, roll-off, dynamic retention, penetration, and other tests required by the individual performance specification standards.

7.1.2 *Impact Headforms*—These headforms shall be made of K1A magnesium material and shall conform to the external dimension requirements of each particular headform size, as specified in Specification F 2220.

7.1.3 *Other Headforms*—These headforms should be made of material of sufficient strength and stiffness to maintain their geometry during testing. They shall conform to the external dimension requirements of each particular headform size, as specified in Specification F 2220. Full-chin headforms will be used as necessary.

7.2 *Retention System*—The test apparatus for the roll-off and dynamic retention testing are shown in Figs. 4 and 5 respectively. The mass of the drop weight and drop height are specified in the individual performance specification standards.

7.2.1 *Roll-Off Cable and Hook*—A flexible strap or cable and attaching hook connect the guide rod to the far edge of the helmet. The flexible strap or cable shall be of a material having an elongation of no more than 18 mm/m when loaded with 1000 N. The cable and hook shall weigh less than 200 g.

7.2.2 *Roll-Off Test Apparatus*—The test apparatus shall be used to apply a shock load to a helmet secured to the headform by its own retention system. The geometry of the test headform shall comply with the dimension of the full chin reference headforms.

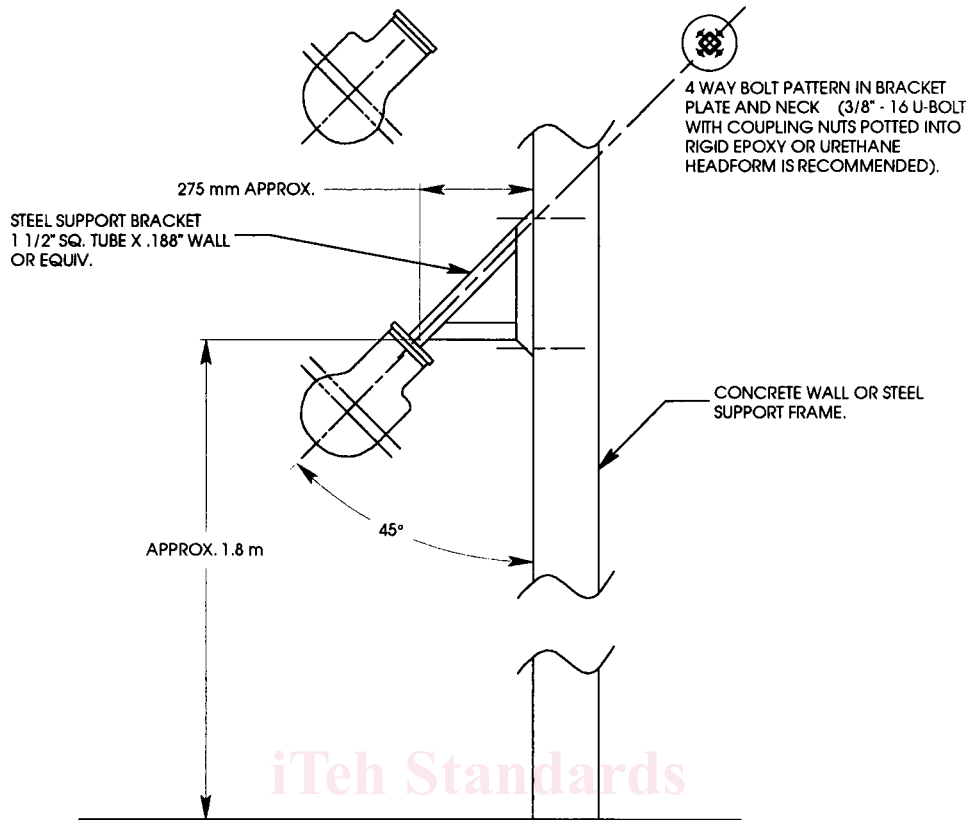

FIG. 4 Typical Apparatus for Roll-off (Stability) Test

The headform shall be secured in a test fixture with its vertical axis pointing downward at 45° to the direction of gravity (see Fig. 4). The test fixture shall permit rotation of the headform about its vertical axis and include a means to lock the headform in the face-up and face-down positions. The guide rod and hammer are similar to those in the dynamic retention strength test minus the simulated jawbone. This equipment shall allow a drop weight to slide in a guided free fall to impact a rigid stop anvil. The guide shall weigh 0.9 to 1.4 kg.

7.2.3 Dynamic Retention Test Apparatus—The retention system test equipment shall allow a drop weight to slide in a guided free fall to impact a rigid stop anvil (see Fig. 5). The geometry of the test headform shall comply with the dimension of the reference headforms. The headform shall be secured in a test fixture with its vertical axis pointing upward in the direction of gravity (see Fig. 5). The guide rod and hammer shall consist of a simulate jawbone, guide rod with stop, drop weight, and position measuring system(s). The entire dynamic test apparatus hangs freely on the retention system. The entire mass of the support assembly, excluding drop weight, must be 7 kg ± 5 %.

7.2.3.1 Simulated Jaw Bone—This stirrup shall consist of two metal bars that spin freely, each with a diameter of 12.5 ± 0.5 mm, that have a center distance of 76.0 ± 1 mm.

7.3 Impact Attenuation—The impact attenuation test apparatus shall allow determination of the impact attenuation characteristics of helmet (see Fig. 6).

7.3.1 Impact Anvils—The selection of anvils to be used for testing any given type of helmet is noted in the individual performance standards. The construction specifications for several types of anvils are given in Figs. 7-11. Other anvils may be specified (including construction specifications) in individual performance standards. All of the anvils, with the exception of the modular elastomer programmer (MEP) specified in these test methods, are constructed of steel and shall be solid (that is, without internal cavities).

7.3.1.1 Modular Elastomer Programmer (MEP)—The MEP is 152 mm in diameter and 25 mm thick. It is affixed to the top surface of a flat, 6.35-mm thick aluminum plate. The durometer hardness of the MEP is 60 ± 2 Shore A.

7.3.1.2 Flat Anvil—The flat anvil shall have a flat surface of a minimum 125-mm diameter circle and shall be at least 24 mm thick (see Fig. 7).

7.3.1.3 Hemispherical Anvil—The hemispherical anvil shall have a spherical surface with a radius of 48 ± 1 mm. The spherical surface shall constitute one half of the surface of a sphere (see Fig. 8).

7.3.1.4 Cylindrical Anvil—The cylindrical anvil shall be one half of a cylinder with a diameter of 75 ± 1 mm and a minimum length of 200 mm (see Fig. 9).

7.3.1.5 Triangular Hazard Anvil—The triangular hazard anvil shall have a 90° ± 0.5° striking edge with a 0.5- to 1.5-mm radius. The height shall be not less than 50 mm and the length not less than 200 mm (see Fig. 10).

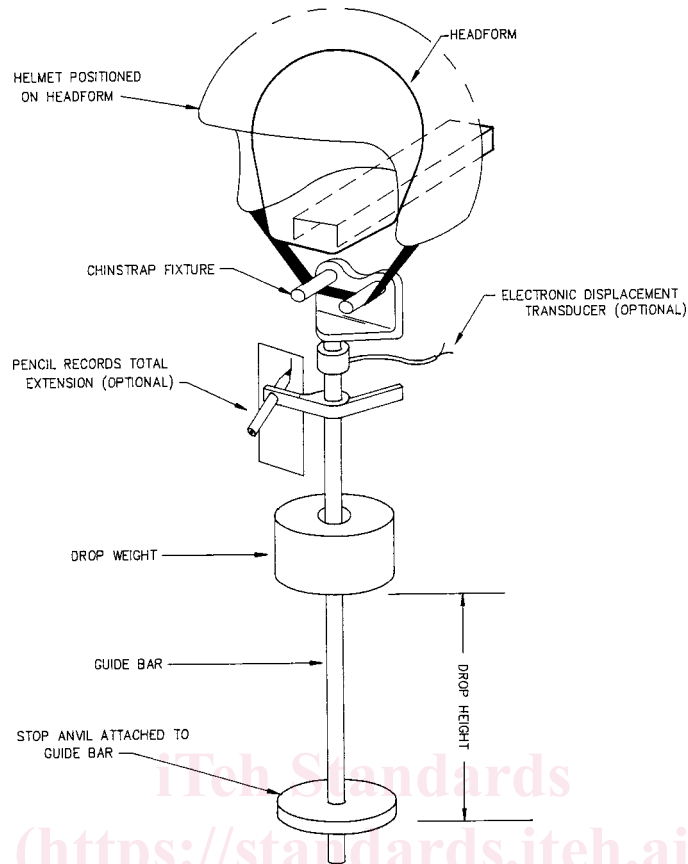

FIG. 5 Typical Apparatus for Retention System Strength and Extension Test

7.3.1.6 *Curbstone Anvil*—The curbstone anvil shall have two faces making an angle of $105^\circ \pm 0.5^\circ$ and meeting along a striking edge with a radius of $15 \text{ mm} \pm 0.5 \text{ mm}$. The height shall be not less than 50 mm and the length not less than 200 mm (see Fig. 11).

7.3.2 *Impact Test Apparatus*—The geometry of the test headform shall comply with the dimension of the Specification F 2220 reference headforms. The headform should be secured in a test fixture to allow for impact of the helmet at any location above the test line. The weight of the drop assembly (which is the combined weight of the instrumented test headform and supporting assembly, exclusive of the test helmet) for the drop test shall be $5 \pm 0.1 \text{ kg}$. The weight of the supporting assembly cannot exceed 1.1 kg. The weight of the support assembly is the weight of the drop assembly minus the weight of the headform, ball clamp, ball clamp bolts, and accelerometer. The center of gravity of the headform shall be at the center of the mounting ball. The center of gravity of the combined test headform and supporting assembly must meet FMVSS 218 S7.1.8 with any type of guide system (see Appendix X1). The helmet and headform are dropped in a guided free fall, using a wire or rail guided apparatus (see Fig. 6), onto an anvil fixed to a rigid base.

7.3.3 *Accelerometer*—Acceleration is measured by a uniaxial accelerometer, which is capable of withstanding a shock of at least 9810 m/s^2 (1000 g) in the headform. The uniaxial accelerometer is mounted at the center of gravity of the test headform with the sensitive axis aligned within 5° of vertical. The acceleration data channel and filtering shall comply with SAE Recommended Practice J211. A low-pass filter (either analog or digital) with a 4-pole Butterworth transfer function and a corner frequency of 1000 Hz meets this requirement.

7.4 *Penetration Testing*—The penetration test headform and support assembly are fastened to a support platform with a steel plate surface at least 24 mm thick and 0.4 m^2 in area (see

7.4 The apparatus shall consist of a striker that shall be guided. An example is shown in Fig. 12). The centerline of the ball does not have to be colinear with the centerline of the striker. The striker weight, geometry, and impact velocity are specified in the individual performance standards.

7.5 The apparatus shall consist of a striker that shall be guided. An example is shown in Fig. 13. The striking surface shall be flat, steel, and have a diameter greater than 112 mm. The total mass of the striker and guide arm shall be $5 \pm 0.2 \text{ kg}$. There shall be a means to securely mount a helmet as shown in Fig. 12. A toggle clamp can be modified to firmly position the helmet by clamping against the inside rear of the helmet. A linear transducer shall be fixed against the inside of the helmet's chin bar to measure deflection. A means of measuring the velocity of the striker in its last 60 mm of fall shall be fitted.