



Designation: ~~C717-07a~~ Designation: **C 717 – 08**

Standard Terminology of Building Seals and Sealants¹

This standard is issued under the fixed designation C 717; the number immediately following the designation indicates the year of original adoption or, in the case of revision, the year of last revision. A number in parentheses indicates the year of last reapproval. A superscript epsilon (ϵ) indicates an editorial change since the last revision or reapproval.

1. Scope

1.1 This standard describes terms and definitions and descriptions of terms used or likely to be used in test methods, specifications, guides, and practices (related to building seals and sealants) consistent with the scope and areas of interest of ASTM Committee C24.

1.2 Definitions and descriptions of terms are written to ensure that building seals and sealants standards are properly understood and interpreted.

2. Referenced Documents

2.1 *ASTM Standards:*²

A 644 Terminology Relating to Iron Castings

C 509 Specification for Elastomeric Cellular Preformed Gasket and Sealing Material

C 542 Specification for Lock-Strip Gaskets

C 716 Specification for Installing Lock-Strip Gaskets and Infill Glazing Materials

C 790 Guide for Use of Latex Sealants³

C 797 Practices for Use of Oil- and Resin-Based Putty and Glazing Compounds

C 961 Test Method for Lap Shear Strength of Sealants

C 964 Guide for Lock-Strip Gasket Glazing

C 1021 Practice for Laboratories Engaged in Testing of Building Sealants

C 1193 Guide for Use of Joint Sealants

D 883 Terminology Relating to Plastics

D 1079 Terminology Relating to Roofing and Waterproofing

D 1565 Specification for Flexible Cellular Materials—Vinyl Chloride Polymers and Copolymers (Open-Cell Foam)⁰

D 1566 Terminology Relating to Rubber

D 2102 Test Method for Shrinkage of Textile Fibers (Bundle Test)

E 631 Terminology of Building Constructions

3. Significance and Use

3.1 *Definitions:*

3.1.1 Terms and their related standard definitions in Section 4 are intended for use uniformly and consistently in all building seals and sealants test methods, specifications, guides, and practices. The purpose of such use is to promote a clear understanding and interpretation of the standards in which they are used.

3.1.2 Definitions of terms are written in the broadest sense possible, consistent with the intended meaning. Definitions have not been limited to a specific technical field when they can have a multi-field application.

3.1.3 The definition of a term that can have different meanings in different technical fields is preceded by a phrase limiting it to the specific field intended, that is, “in building construction.”

3.2 *Description of Terms:*

3.2.1 Descriptions of Terms are special purpose definitions intended to provide a precise understanding and interpretation of the seals and sealants standards in which they are used.

3.2.2 A specific description of a term is applicable to the standard or standards in which the term is described and used.

¹ This terminology is under the jurisdiction of ASTM Committee C24 on Building Seals and Sealants and is the direct responsibility of Subcommittee C24.01 on Terminology of Building Seals and Sealants.

The boldface designations refer to the original source of the definition and the ASTM Technical Committee having jurisdiction.

Current edition approved July 1, 2007; 2008. Published August 2007; May 2008. Originally approved in 1972. Last previous edition approved in 2007 as C 717 – 07a.
² For referenced ASTM standards, visit the ASTM website, www.astm.org, or contact ASTM Customer Service at service@astm.org. For *Annual Book of ASTM Standards* volume information, refer to the standard's Document Summary page on the ASTM website.

³ Withdrawn.

3.2.3 Each standard in which a term is used, in a specially defined manner, should list the term and its description under the subheading, descriptions of terms.

4. Terminology

4.1 Terms and Definitions:

adhesive failure, n— *in building construction*, failure of the bond between the sealant, adhesive, or coating and the substrate surface.

aerosol container, empty, n—*in building construction*, an aerosol container is considered empty when the product flow reaches 0.5 g per second or less.

back bedding, n— See **bedding**.

back putty, n— See **bedding**.

back-up material—See **sealant backing**.

band aid sealant joint, n—Use **bridge sealant joint** (preferred term).

bead, n—*in building construction*, in sealants and glazing, a strip of applied sealant, glazing compound, or putty.

bed, v—*in building construction in glazing*, to apply a bead of sealant between a lite of glass or a panel and the stationary stops or sight bars of the sash or frame.

bed, n—See **bedding**.

bedding, n—*in building construction in glazing*, a bead of sealant applied between a lite of glass or a panel and the stationary stop or sight bar of the sash or frame. It is usually the first bead to be applied when setting glass or panels.

bicellular sealant backing, n—a flexible and very compressible extruded shape (usually cylindrical), with a surface skin, that is composed of both open and closed cell material.

bite, n—*in building construction in glazing*, the effective structural contact dimension of a structural sealant. (See Fig. 1 and Fig. 2.)

bloom, n—*in building construction*, a substance formed by blooming.

blooming, v—*in building construction*, movement or diffusion of a component such as a plasticizer, monomer, unreacted polymer or other formulation ingredient to a sealant surface.

bond breaker—*in building construction*, a material to prevent adhesion at a designated interface.

bridge sealant joint, n— *in building construction*, a joint where sealant is applied over the joint to the face of substrates that are in approximately the same plane (see Fig. 3).

DISCUSSION—Not to be confused with joints in bridges.

building seal—See **seal**.

butt glazing, n—*in building construction*, a glazing system wherein butt joints are formed between lites and filled with a glazing sealant.

butt joint, n— See **butt sealant joint**. (See Fig. 4.)

butt sealant joint, n— *in building construction*, a joint where sealant is applied within the joint between approximately parallel substrate surfaces that are face-to-edge or edge-to-edge. (See Fig. 4.)

caulk, v—*in building construction*, to install or apply a sealant across or into a joint, crack, or crevice.

caulk, n—See **sealant**.

caulking, n—See **sealant**.

caulking compound, n— See **sealant**.

cell, n—a single small cavity surrounded partially or completely by walls.

D 1566; D11

cellular material, n—a generic term for materials containing many cells (either open, closed, or both) dispersed through the mass.

D 1565, D 1566; D11

chalk, n—*in building construction*, a powder formed by chalking

DISCUSSION—The powder is not necessarily white.

chalking, v—*in building construction*, formation of a powder on the surface of a sealant that is caused by the disintegration of the polymer or binding medium due to weathering.

DISCUSSION—Chalk on a light color sealant is often white, however a darker color can also exhibit chalking.

closed cell, n—a cell totally enclosed by its walls and hence not interconnecting with other cells.

D 883; D20

closed cell material, n—a cellular material in which substantially all cells in the mass are closed cells.

closed cell sealant backing, n—*in building construction*, a flexible and somewhat compressible extruded shape (usually cylindrical), with a surface skin, that is composed of closed cell material.

cohesive failure, n— *in building construction*, failure characterized by rupture within the sealant, adhesive, or coating.

compatibility, n— *in building construction*, the capability of two or more materials to be placed in contact or close proximity with no detrimental interaction.

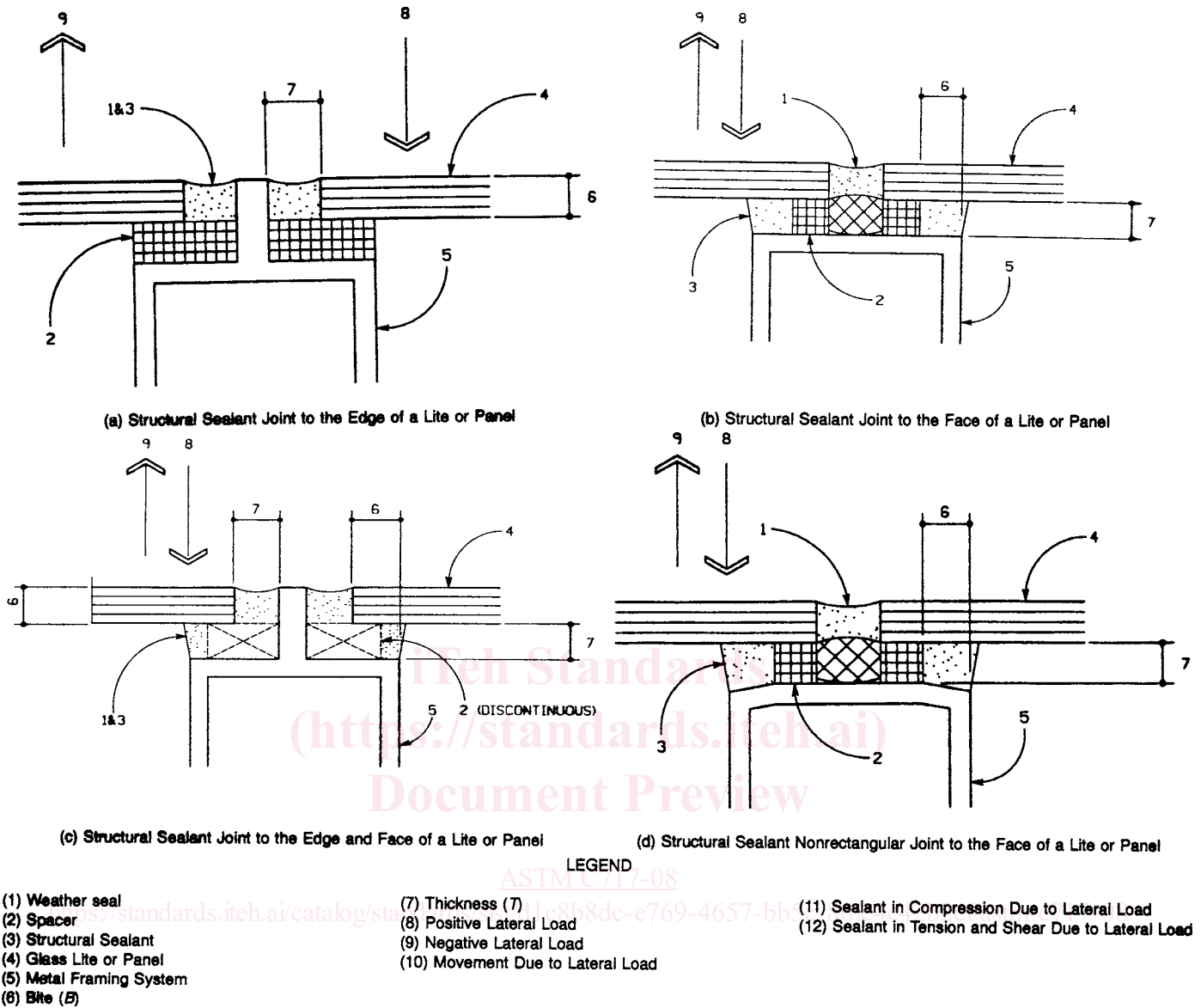

FIG. 1 Typical Structural Sealant Joint Configurations

DISCUSSION—Compatibility for a sealant is characterized by, among others, no significant change in adhesive and cohesive properties or aesthetic appearance for its service life.

compatible materials, *n*— in building construction, compounds or substances that can exist in close proximity to one another without detrimental effects on either.

compound, *n*—an intimate mixture of all the ingredients necessary for a finished material or product.

compression gasket, *n*—a gasket designed to be used under compression.

compression glazing, *n*—see **compression glazing system**.

compression glazing, *v*— in building construction, the act of installing components into a compression glazing system.

compression glazing system, *n*—in building construction, gasket(s) or a combination of sealant(s) and gasket(s) used to provide weather-tightness by way of continuous pressure on the components in the joint.

compression seal, *n*—a seal which is attained by a compressive force on the sealing material.

construction joint, *n*— in building construction, a formed or assembled joint at a predetermined location where two successive placements (“lifts”) of concrete meet.

DISCUSSION—Frequently a keyway or reinforcement is placed across the joint. With proper design, this joint may also function as a control or an isolation joint.

control joint, *n*— in building construction, a formed, sawed, tooled, or assembled joint acting to regulate the location and degree of cracking and separation resulting from the dimensional change of different elements of a structure.

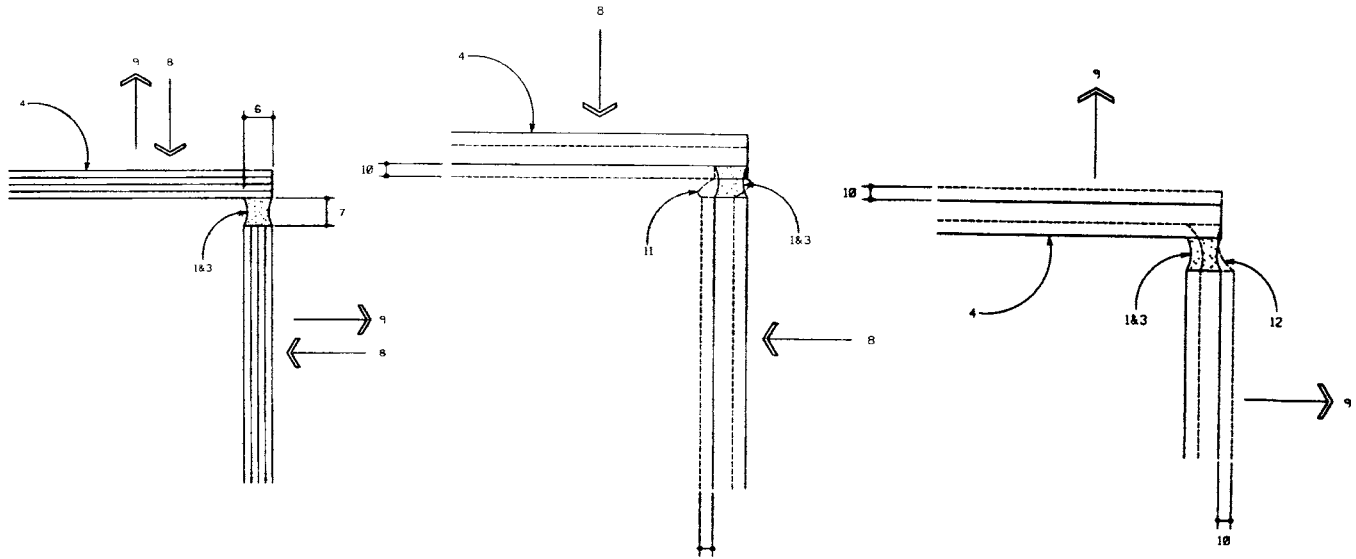

(a) Vertical Corner With One Lite or Panel Structurally Sealed to the Other

(b) Positive Applied Lateral Load

(c) Negative Applied Lateral Load

FIG. 2 Applied Load Transfer at a Vertical Corner Structural Sealant Joint (see Fig. 1 for Legend)

FIGURE LEGEND

- A SEALANT
- B SEALANT BACKING
- C BOND BREAKER
- D JOINT
- E SUBSTRATE FACE
- F SUBSTRATE EDGE

ASTM C 717-08

<https://standards.iteh.ai/catalog/standards/sist/d1c8b8dc-e769-4657-bb5c-8dfe4c42b2cf/astm-c717-08>

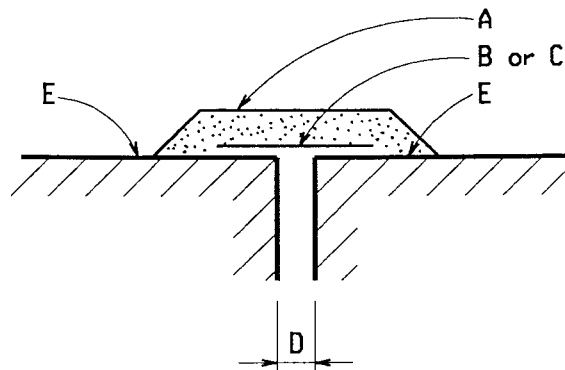

FIG. 3 Bridge Sealant Joint

DISCUSSION—The joint is usually installed in concrete and concrete masonry construction to induce controlled cracking at preselected locations or where a concentration of stresses is expected.

crazed, *adj*—*in building construction*, having a random network of cracks in a sealant surface which do not penetrate through the body of the material.

crazed, *adj*—*in building construction*, exhibiting crazing.

crazing, *n*—*in building construction*, a network of fine cracks on the surface of a sealant.

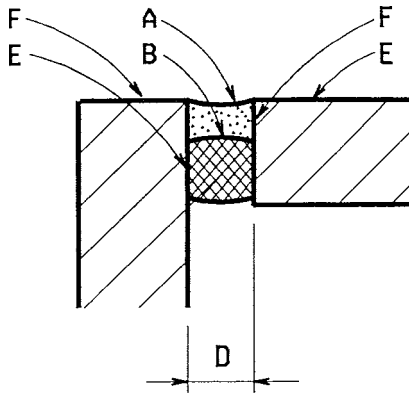

a. face to edge

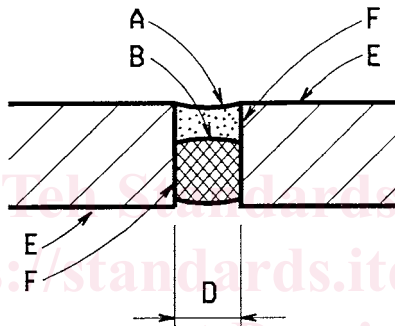

b. edge to edge

- A—Sealant
- B—Sealant backing
- C—Bond breaker
- D—Joint
- E—Substrate face
- F—Substrate edge

FIG. 4 Butt Sealant Joint

DISCUSSION—Crazing may or may not affect product performance.

crazing, *v*—*in building construction*, the formation of a network of random surface cracks in a sealant.

creep, *n*—the time dependent part of a strain resulting from stress.

D 1079; D08

cure, *v*—*in building construction*, to attain the intended performance properties of a compound by means of evaporation, chemical reaction, heat, radiation, or combinations thereof.

cure, *n*—*in building construction*, the process by which a compound attains its intended performance properties by means of evaporation, chemical reaction, heat, radiation, or combinations thereof.

cured, *adj*—*in building construction*, pertaining to the state of a compound that has attained its intended performance properties by means of evaporation, chemical reaction, heat, radiation, or combinations thereof.

dense rubber, *n*— *in building construction*, a solid rubber material substantially free of cells or porosity.

dirt pick-up, *n*— *in building construction*, soiling caused by a foreign material other than micro-organism growth that is deposited on, adhered to, or embedded into a sealant.

DISCUSSION—Micro-organism growth can produce a similar appearance.

durability—*in building construction*, a general term for resistance to deleterious change of an installed sealant.

DISCUSSION—Durability describes the ability of a sealant to maintain the required properties for its intended service. Durability is based on the length of time that a sealant can maintain its innate characteristics in use. This time will vary depending on the environment and use of the sealant (for example, outdoor versus indoor use).

durability limit, *n*—see the preferred term, **service life**.

edge spacer, *n*— *in building construction in glazing*, a spacer placed to prevent edge contact and to position laterally a pane of glass or a panel within the supporting frame.

elastomer, *n*—a macromolecular material that returns rapidly to approximately its original dimensions and shape after substantial deformation by a weak force and release of the force.

DISCUSSION—a) Elastomers are divided into two major polymer systems—thermoset and thermoplastic. b) In standards for rubber, the word elastomer is not to be used interchangeably for the term “rubber”. **D 1566; D11**

elastomeric, *adj*—having the characteristics of an elastomer.

elongation, *n*—extension produced by a tensile stress. **D 1566; D11**

expanded rubber, *n*— *in building construction*, an elastomeric closed-cell material made by incorporating a gas-producing ingredient into a rubber compound that decomposes during vulcanization, producing gas bubbles that expand the compound; the bubbles are predominately non-interconnecting.

expansion joint, *n*— *in building construction*, a formed or assembled joint at a predetermined location, which prevent the transfer of forces across the joint as a result of movement or dimensional change of different elements of a structure or building.

expansion joint seal, *n*— *in building construction*, a seal or sealant system that provides an elastic, compressible, or flexible barrier to the passage of gases, liquids, or solids.

extrudability, *n*— *in building construction*, the ability of a sealant under pressure to flow through an orifice.

face glazing, *n*—the method of glazing in which a rabbeted glazing recess, with no removable stop, is used and a triangular bead of compound is applied to the face of the lite and extended onto the recess.

fillet bead joint, *n*—Use **fillet sealant joint** (preferred term). (See Fig. 5.)

fillet sealant joint, *n*— *in building construction*, a joint where sealant is applied over the joint to the face of substrates that are approximately perpendicular to each other (see Fig. 5).

flow, *v*—*in building construction*, the deformation of a tape sealant under stress.

fluid migration, *n*— *in building construction*, accumulation of a fluid from a sealant on or in an adjacent material.

DISCUSSION—Migration of a non-fluid component can also occur.

four-side structural sealant glazing, *n*—*in building construction*, a glazing system wherein all sides of a rectangular-shaped lite or panel are structural sealant glazed.

gasket, *n*—any preformed, deformable device designed to be placed between two adjoining parts to provide a seal.

glazing, *v*—*in building construction*, the installation of glass or other materials in prepared openings.

glazing compound, *n*— *in building construction in glazing*, a putty material composed primarily of oil- or resin-based ingredients used for sealing window glass in frames.

DISCUSSION—Historically these compounds cure primarily through solvent evaporation, oxidation or both. Compounds other than oil- or resin-based can be used for glazing, though they may not have a putty-like consistency.

glazing, construction site, *n*—*in building construction*, the installation of glass or panels into a metal framing system, at a construction site, under generally uncontrolled environmental conditions.

glazing, factory, *n*— See **glazing, shop**.

glazing, field, *n*— See **glazing, construction site**.

glazing, protective, *n*— *in building construction*, systems with glazed openings that are designed to mitigate the effects of bomb blasts, projectiles, natural disasters, or forced entry.

DISCUSSION—Protective glazing systems assist in the mitigation of the potential for hazardous debris dispersal from natural disasters, withstand projectile impact and resist unauthorized human entry through glazed openings. Protective glazing systems include the selection of an appropriate glazing material, the design of metal framing members and their anchorages, and the retention of the glazing material within the framing all to resist a specified threat.

glazing, shop, *n*— *in building construction*, the installation of glass or panels into a metal framing system under controlled environmental conditions.

DISCUSSION—Shop glazing typically occurs at a location remote to a construction site. However, shop glazing can be performed at the construction site if acceptable to the code authority and provided appropriate management controls and environmental conditions are maintained.

gun-grade, *n*—*in building construction*, a material of a suitable viscosity to extrude through the nozzle of a hand- or power-operated device.

hardness, *n*—*in building construction*, the resistance to indentation as measured under specified conditions. **A 644; A04**

hydrostatic pressure, *n*—a state of stress in which all the principal stresses are equal (and there is no shear stress), as in a liquid at rest; the product of the unit weight of the liquid and the difference in elevation between the given point and the free liquid elevation.

isolation joint, *n*— *in building construction*, a formed or assembled joint specifically intended to separate and prevent the bonding of one element of a structure to another and having little or no transference of movement or vibration across the joint.

joint, *n*—*in building construction*, the space or opening between two or more adjoining surfaces.