

SLOVENSKI STANDARD
oSIST prEN ISO 25239-1:2019
01-julij-2019

Varjenje z gnetenjem - Aluminij - 1. del: Slovar (ISO/DIS 25239-1:2019)

Friction stir welding - Aluminium - Part 1: Vocabulary (ISO/DIS 25239-1:2019)

Rührreibschweißen - Aluminium - Teil 1: Begriffe (ISO/DIS 25239-1:2019)

Soudage par friction-malaxage - Aluminium - Partie 1: Vocabulaire (ISO/DIS 25239-1:2019)

Ta slovenski standard je istoveten z: prEN ISO 25239-1

ICS:

01.040.25	Izdelavna tehnika (Slovarji)	Manufacturing engineering (Vocabularies)
25.160.10	Varilni postopki in varjenje	Welding processes
77.120.10	Aluminij in aluminijeve zlitine	Aluminium and aluminium alloys

oSIST prEN ISO 25239-1:2019

en,fr,de

iTeh STANDARD PREVIEW
(standards.iteh.ai)

Full standard:
<https://standards.iteh.ai/catalog/standards/sist/b9eade77-69e-c-4cab-9eb6-f5eed0203ae/osist-pre-iso-25239-1-2019>

DRAFT INTERNATIONAL STANDARD

ISO/DIS 25239-1

IIW

Secretariat: **ISO secretariat**Voting begins on:
2019-05-22Voting terminates on:
2019-08-14

Friction stir welding — Aluminium —

Part 1: Vocabulary

Soudage par friction-malaxage — Aluminium —

Partie 1: Vocabulaire

ICS: 01.040.25; 25.160.10

!Teh STANDARD PREVIEW
(standards.iteh.ai)
Full standard:
<https://standards.iteh.ai/catalog/standards/sist/b9eade7f-69ec-4cab-9eb6-f5eedd0203a6/osist-pr-en-iso-25239-1-2019>

Member bodies are requested to consult relevant national interests in ISO/TC 44/SC 10 before casting their ballot to the e-Balloting application.

This document is circulated as received from the committee secretariat.

ISO/CEN PARALLEL PROCESSING

This draft International Standard is submitted to all ISO member bodies for voting, as a standard prepared by an international standardizing body in accordance with Council Resolution 42/1999. The proposer, the International Institute of Welding (IIW), has been recognized by the ISO Council as an international standardizing body for the purpose of Council Resolution 42/1999.

THIS DOCUMENT IS A DRAFT CIRCULATED FOR COMMENT AND APPROVAL. IT IS THEREFORE SUBJECT TO CHANGE AND MAY NOT BE REFERRED TO AS AN INTERNATIONAL STANDARD UNTIL PUBLISHED AS SUCH.

IN ADDITION TO THEIR EVALUATION AS BEING ACCEPTABLE FOR INDUSTRIAL, TECHNOLOGICAL, COMMERCIAL AND USER PURPOSES, DRAFT INTERNATIONAL STANDARDS MAY ON OCCASION HAVE TO BE CONSIDERED IN THE LIGHT OF THEIR POTENTIAL TO BECOME STANDARDS TO WHICH REFERENCE MAY BE MADE IN NATIONAL REGULATIONS.

RECIPIENTS OF THIS DRAFT ARE INVITED TO SUBMIT, WITH THEIR COMMENTS, NOTIFICATION OF ANY RELEVANT PATENT RIGHTS OF WHICH THEY ARE AWARE AND TO PROVIDE SUPPORTING DOCUMENTATION.



Reference number
ISO/DIS 25239-1:2019(E)

ITeH STANDARD PREVIEW
(standards.iteh.ai)
Full standard:
<https://standards.iteh.ai/catalog/standards/sist/b9eade77-69ec-4cab-9eb6-f5eed0203ae/osist-pr-en-iso-25239-1-2019>



COPYRIGHT PROTECTED DOCUMENT

© ISO 2019

All rights reserved. Unless otherwise specified, or required in the context of its implementation, no part of this publication may be reproduced or utilized otherwise in any form or by any means, electronic or mechanical, including photocopying, or posting on the internet or an intranet, without prior written permission. Permission can be requested from either ISO at the address below or ISO's member body in the country of the requester.

ISO copyright office
CP 401 • Ch. de Blandonnet 8
CH-1214 Vernier, Geneva
Phone: +41 22 749 01 11
Fax: +41 22 749 09 47
Email: copyright@iso.org
Website: www.iso.org

Published in Switzerland

Contents

	Page
Foreword.....	iv
Introduction.....	v
1 Scope.....	1
2 Terms and definitions.....	1
Bibliography.....	16

ITeH STANDARD PREVIEW
(standards.iteh.ai)
Full standard:
<https://standards.iteh.ai/catalog/standards/sist/b9eade77-69e-c-4cab-9eb6-f5eed0203ae/osist-pr-en-iso-25239-1-2019>

ISO/DIS 25239-1:2019(E)

Foreword

ISO (the International Organization for Standardization) is a worldwide federation of national standards bodies (ISO member bodies). The work of preparing International Standards is normally carried out through ISO technical committees. Each member body interested in a subject for which a technical committee has been established has the right to be represented on that committee. International organizations, governmental and non-governmental, in liaison with ISO, also take part in the work. ISO collaborates closely with the International Electrotechnical Commission (IEC) on all matters of electrotechnical standardization.

The procedures used to develop this document and those intended for its further maintenance are described in the ISO/IEC Directives, Part 1. In particular, the different approval criteria needed for the different types of ISO documents should be noted. This document was drafted in accordance with the editorial rules of the ISO/IEC Directives, Part 2 (see www.iso.org/directives).

Attention is drawn to the possibility that some of the elements of this document may be the subject of patent rights. ISO shall not be held responsible for identifying any or all such patent rights. Details of any patent rights identified during the development of the document will be in the Introduction and/or on the ISO list of patent declarations received (see www.iso.org/patents).

Any trade name used in this document is information given for the convenience of users and does not constitute an endorsement.

For an explanation of the voluntary nature of standards, the meaning of ISO specific terms and expressions related to conformity assessment, as well as information about ISO's adherence to the World Trade Organization (WTO) principles in the Technical Barriers to Trade (TBT), see www.iso.org/iso/foreword.html.

This document was prepared by IIW, International Institute of Welding, Commission III, *Resistance Welding, Solid State Welding and Allied Joining Process*.

This second edition cancels and replaces the first edition (ISO 25239-1:2011), which has been technically revised.

The main changes compared to the previous edition are as follows:

- to be entered closer to publication

A list of all parts in the ISO 25239- series can be found on the ISO website.

Any feedback or questions on this document should be directed to the user's national standards body. A complete listing of these bodies can be found at www.iso.org/members.html.

Introduction

Welding processes are widely used in the fabrication of engineered structures. During the second half of the twentieth century, fusion welding processes, wherein fusion is obtained by the melting of parent material and usually a filler metal, dominated the welding of large structures. Then, in 1991, Wayne Thomas at TWI invented friction stir welding (FSW), which is carried out entirely in the solid phase (no melting).

The increasing use of FSW has created the need for this document in order to ensure that welding is carried out in the most effective way and that appropriate control is exercised over all aspects of the operation. This document focuses on the FSW of aluminium because, at the time of publication, the majority of commercial applications for FSW involved aluminium. Examples include railway carriages, consumer products, food processing equipment, aerospace structures, and marine vessels.

The parts of this document are:

Part 1: Vocabulary, defines terms specific to FSW.

Part 2: Design of weld joints, specifies design requirements for friction stir weld joints in aluminium.

Part 3: Qualification of welding operators, specifies requirements for the qualification of a welding operator for the FSW of aluminium.

Part 4: Specification and qualification of welding procedures, specifies requirements for the specification and qualification of welding procedures for the FSW of aluminium. A welding procedure specification (WPS) is needed to provide a basis for planning welding operations and for quality control during welding. Welding is considered a special process in the terminology of standards for quality systems. Standards for quality systems usually require that special processes be carried out in accordance with written procedure specifications. Metallurgical deviations constitute a special problem. Because non-destructive testing of the mechanical properties is impossible at the present level of technology, this has resulted in the establishment of a set of rules for qualification of the welding procedure prior to the release of the WPS to actual production. ISO 25239-4 defines these rules.

Part 5: Quality and inspection requirements, specifies a method for determining the capability of a fabricator to use the FSW process for the production of aluminium products of the specified quality. It defines specific quality requirements but does not assign those requirements to any specific product group. To be effective, welded structures should be free from serious problems in production and in service. To achieve that goal, it is necessary to provide controls from the design phase through material selection, fabrication, and inspection. For example, poor design can create serious and costly difficulties in the workshop, on site, or in service. Incorrect material selection can result in welding problems, such as cracking. Welding procedures have to be correctly formulated and qualified to avoid imperfections. To ensure the fabrication of a quality product, management should understand the sources of potential trouble and introduce appropriate quality and inspection procedures. Supervision should be implemented to ensure that the specified quality is achieved.

ITeH STANDARD PREVIEW
(standards.iteh.ai)

Full standard:
<https://standards.iteh.ai/catalog/standards/sist/b9eade77-69e-c4ca-b9eb6-f5eed0203ae/osist-pre-niso-25239-1-2019>

Friction stir welding — Aluminium —

Part 1: Vocabulary

1 Scope

This part of ISO 25239 defines friction stir welding terms. In this part of ISO 25239, the term “aluminium” refers to aluminium and its alloys.

NOTE In addition to terms in English and French (two of the three official ISO languages), this part of ISO 25239 gives the equivalent terms in German; these are published under the responsibility of the member body for Germany (DIN). However, only the terms and definitions given in the official languages can be considered as ISO terms and definitions.

2 Terms and definitions

For the purposes of this document, the following terms and definitions apply.

ISO and IEC maintain terminological databases for use in standardization at the following addresses:

- ISO Online browsing platform: available at <https://www.iso.org/obp>
- IEC Electropedia: available at <http://www.electropedia.org/>

2.1

adjustable tool probe

tool whose probe length, rotation speed, and direction of probe rotation are adjustable, and rotation and speed of direction may be different from those of the shoulder during welding

Note 1 to entry: See [Figure 1](#).

Note 2 to entry: This tool enables joining to be accomplished without creating excessive toe flash at the start and exit hole.

ISO/DIS 25239-1:2019(E)

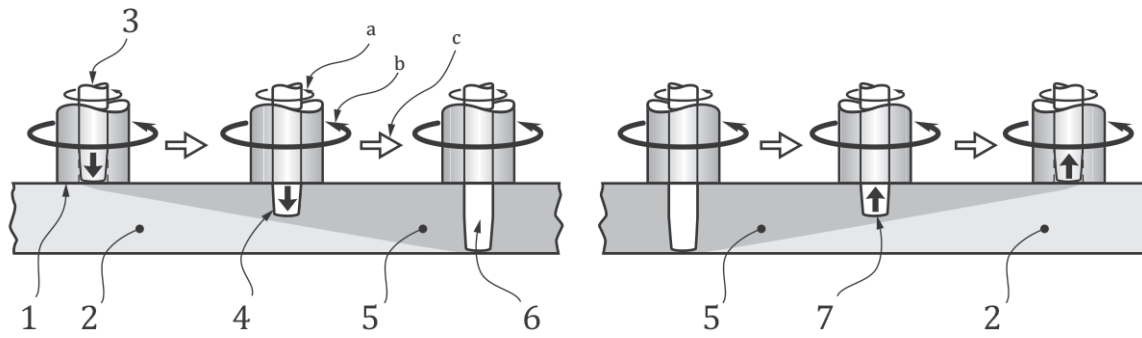
**Key**

- 1 shoulder
- 2 unwelded workpiece
- 3 probe
- 4 probe moving downward
- 5 welded workpiece
- 6 probe at required position for welding
- 7 probe moving upward
- a Direction of probe rotation.
- b Direction of shoulder rotation.
- c Direction of welding.

Figure 1 — Adjustable tool probe**2.2****advancing side**

side of the weld where the direction of tool rotation is the same as the direction of welding

Note 1 to entry: See [Figure 2](#).