

Second edition
2016-03-01

Corrected version
2016-09-01

**Resistance welding — Destructive
testing of welds — Specimen
dimensions and procedure for cross
tension testing of resistance spot and
embossed projection welds**

*Soudage par résistance — Essais destructifs des soudures —
Dimensions des éprouvettes et mode opératoire pour l'essai de
traction en croix des soudures par résistance par points et par
bossages*

ISO 14272:2016

<https://standards.iteh.ai/catalog/standards/sist/b00f87ec-7e46-4306-90ae-ec42b539daeb/iso-14272-2016>



Reference number
ISO 14272:2016(E)

© ISO 2016

iTeh STANDARD PREVIEW
(standards.iteh.ai)

ISO 14272:2016

<https://standards.iteh.ai/catalog/standards/sist/b00f87ec-7e46-4306-90ae-ec42b539daeb/iso-14272-2016>



COPYRIGHT PROTECTED DOCUMENT

© ISO 2016, Published in Switzerland

All rights reserved. Unless otherwise specified, no part of this publication may be reproduced or utilized otherwise in any form or by any means, electronic or mechanical, including photocopying, or posting on the internet or an intranet, without prior written permission. Permission can be requested from either ISO at the address below or ISO's member body in the country of the requester.

ISO copyright office
Ch. de Blandonnet 8 • CP 401
CH-1214 Vernier, Geneva, Switzerland
Tel. +41 22 749 01 11
Fax +41 22 749 09 47
copyright@iso.org
www.iso.org

Contents

	Page
Foreword	iv
Introduction	v
1 Scope	1
2 Normative references	1
3 Terms and definitions	1
4 Test specimen	1
5 Test equipment and testing procedure	3
6 Test report	6
Annex A (informative) Exploded view of a hydraulic clamping device	8
Bibliography	10

iTeh STANDARD PREVIEW (standards.iteh.ai)

ISO 14272:2016

<https://standards.iteh.ai/catalog/standards/sist/b00f87ec-7e46-4306-90ae-ec42b539daeb/iso-14272-2016>

Foreword

ISO (the International Organization for Standardization) is a worldwide federation of national standards bodies (ISO member bodies). The work of preparing International Standards is normally carried out through ISO technical committees. Each member body interested in a subject for which a technical committee has been established has the right to be represented on that committee. International organizations, governmental and non-governmental, in liaison with ISO, also take part in the work. ISO collaborates closely with the International Electrotechnical Commission (IEC) on all matters of electrotechnical standardization.

The procedures used to develop this document and those intended for its further maintenance are described in the ISO/IEC Directives, Part 1. In particular the different approval criteria needed for the different types of ISO documents should be noted. This document was drafted in accordance with the editorial rules of the ISO/IEC Directives, Part 2 (see www.iso.org/directives).

Attention is drawn to the possibility that some of the elements of this document may be the subject of patent rights. ISO shall not be held responsible for identifying any or all such patent rights. Details of any patent rights identified during the development of the document will be in the Introduction and/or on the ISO list of patent declarations received (see www.iso.org/patents).

Any trade name used in this document is information given for the convenience of users and does not constitute an endorsement.

For an explanation on the meaning of ISO specific terms and expressions related to conformity assessment, as well as information about ISO's adherence to the WTO principles in the Technical Barriers to Trade (TBT) see the following URL: [Foreword - Supplementary information](#)

The committee responsible for this document is ISO/IIW, *International Institute of Welding*, Commission III.

This second edition cancels and replaces the first edition (ISO 14272:2000), which has been technically revised.

This corrected version of ISO 14272:2016 incorporates the following corrections:

- [Figure 4](#) a) has been corrected.

Requests for official interpretations of any aspect of this International Standard should be directed to the ISO Central Secretariat, who will forward them to the IIW Secretariat for an official response.

Introduction

This edition of ISO 14272 no longer includes figures showing failure types and modes for tensile shear and cross tension testing in accordance with ISO 14329.

ISO 14272 has been revised to align it with ISO 17677-1.

iTeh STANDARD PREVIEW (standards.iteh.ai)

[ISO 14272:2016](https://standards.iteh.ai/catalog/standards/sist/b00f87ec-7e46-4306-90ae-ec42b539daeb/iso-14272-2016)

<https://standards.iteh.ai/catalog/standards/sist/b00f87ec-7e46-4306-90ae-ec42b539daeb/iso-14272-2016>

iTeh STANDARD PREVIEW
(standards.iteh.ai)

ISO 14272:2016

<https://standards.iteh.ai/catalog/standards/sist/b00f87ec-7e46-4306-90ae-ec42b539daeb/iso-14272-2016>

Resistance welding — Destructive testing of welds — Specimen dimensions and procedure for cross tension testing of resistance spot and embossed projection welds

1 Scope

This International Standard specifies specimen dimensions and a testing procedure for the cross tension testing of spot and projection welds in overlapping sheets in any metallic material of thickness 0,5 mm to 3 mm, where the welds have a maximum diameter of $7\sqrt{t}$ (where t is the sheet thickness in mm).

The object of cross tension testing is to determine the tensile force that the test specimen can sustain.

2 Normative references

The following documents, in whole or in part, are normatively referenced in this document and are indispensable for its application. For dated references, only the edition cited applies. For undated references, the latest edition of the referenced document (including any amendments) applies.

ISO 7500-1, *Metallic materials — Verification of static uniaxial testing machines — Part 1: Tension/compression testing machines — Verification and calibration of the force-measuring system*

ISO 17677-1, *Resistance welding — Vocabulary — Part 1: Spot, projection and seam welding*

3 Terms and definitions

ISO 14272:2016

[https://standards.iteh.ai/catalog/standards/sist/b00f87ec-7e46-4306-90ac-](https://standards.iteh.ai/catalog/standards/sist/b00f87ec-7e46-4306-90ac-ec42b539daeb/iso-14272-2016)

[ec42b539daeb/iso-14272-2016](https://standards.iteh.ai/catalog/standards/sist/b00f87ec-7e46-4306-90ac-ec42b539daeb/iso-14272-2016)

For the purposes of this document, the terms and definitions given in ISO 17677-1 and the following apply.

3.1

cross tension strength

CTS

maximum cross tension force obtained from this test

3.2

cross tension force

force applied on test specimen during cross tension testing

4 Test specimen

The test specimen is composed of two rectangular coupons as shown in [Figure 1](#). If clamping bolts are used, two holes shall be drilled in each coupon. If a hydraulic clamping system is used for clamping, no holes are required.

The weld shall be centred in the test specimen with a tolerance of ± 1 mm to every direction.

[Figures 2](#) and [3](#) illustrate examples of a welding jig/template, which can be used for welding the two sheets together. Two punched strips are placed at right angles to each other, held in the jig, and welded together. To obtain a statistically significant average, several specimens shall be tested.

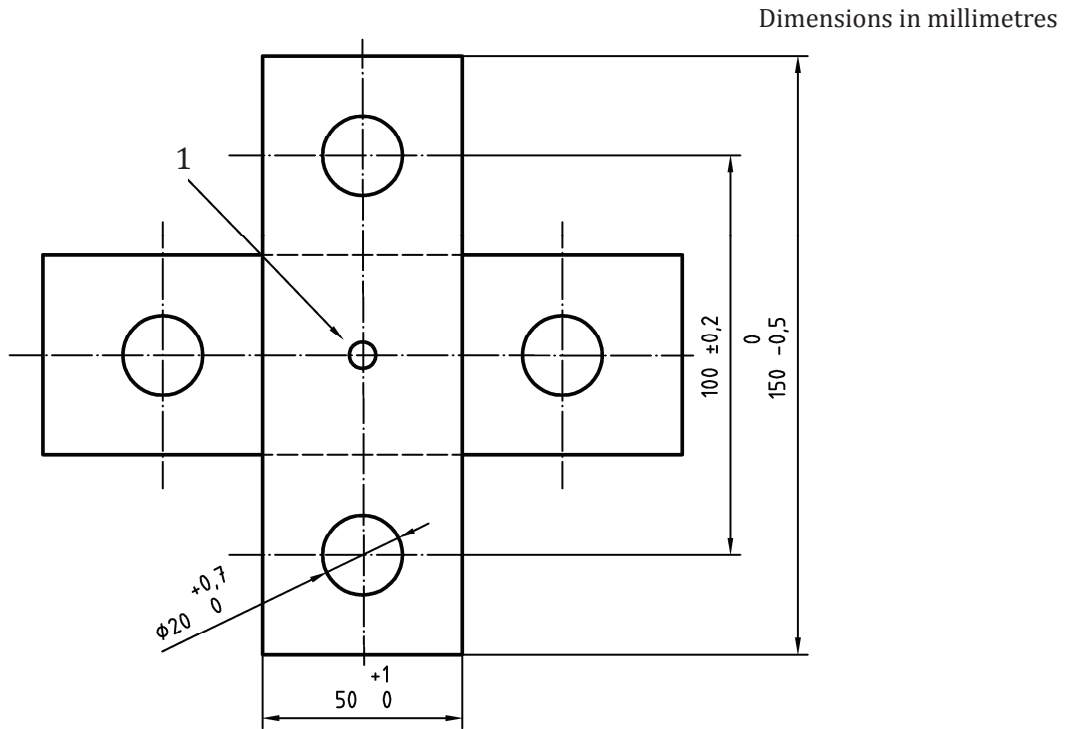

- Key**
 1 weld

iTeh STANDARD PREVIEW
 (standards.iteh.ai)

Figure 1 — Test specimen for cross tension test

ISO 14272:2016
<https://standards.iteh.ai/catalog/standards/sist/b00f87ec-7e46-4306-9000-ec42b539daeb/iso-14272-2016> Dimensions in millimetres

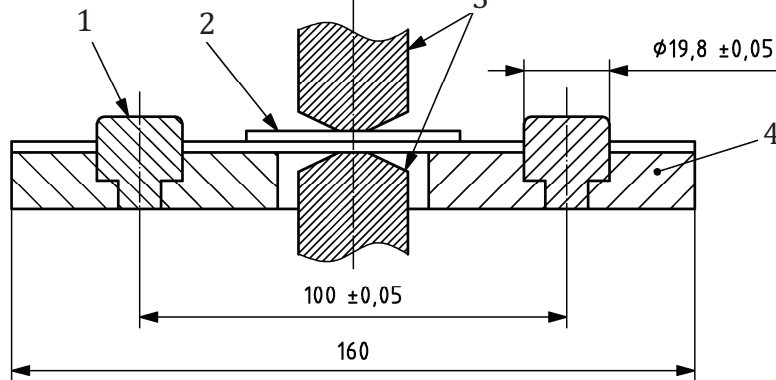

- Key**
 1 locator pin
 2 test specimen
 3 welding electrode
 4 insulation material

Figure 2 — Example of a welding jig for welding cross tension test specimens with holes

Dimensions in millimetres

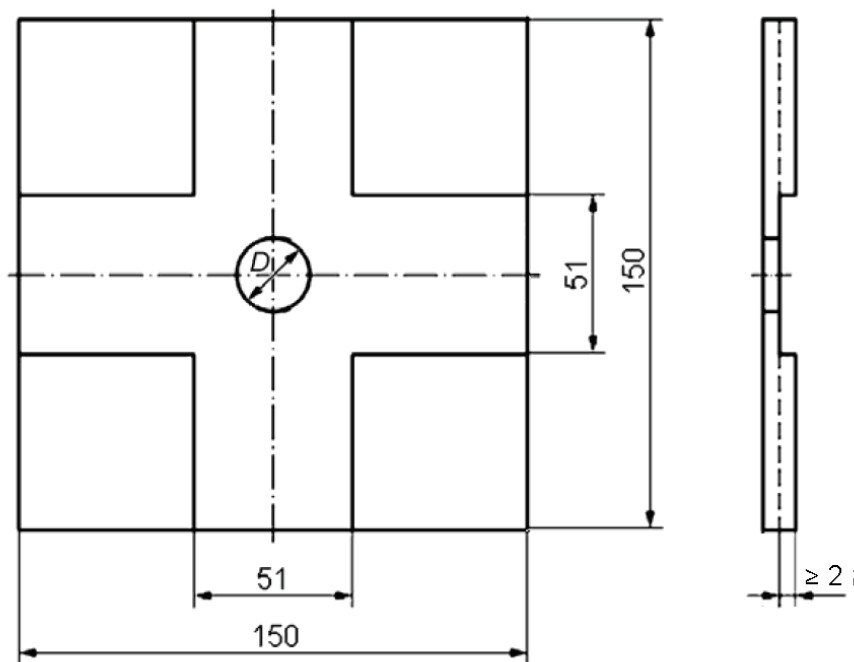
**Key**

- D hole diameter
 t sheet thickness

iTeh STANDARD PREVIEW
(standards.iteh.ai)

NOTE For specimens without holes (clamping bolts), the hole diameter and thickness of the welding jig/template can be determined in accordance with the electrode configuration.
ISO 14272:2016
 ec42b539daeb/iso-14272-2016

Figure 3 — Example of a welding jig for welding cross tension test specimens without holes

5 Test equipment and testing procedure

For test specimens with holes and clamping bolts, the assembled specimen shall be held in clamps as shown in [Figure 4](#). For test specimens without holes a hydraulic clamping system, as shown in [Figure 5](#), can be used in place of the testing clamps illustrated in [Figure 4](#).

After clamping, the test specimen shall be pulled apart using a tensile testing machine, which satisfies the requirements of ISO 7500-1. The measurement accuracy of force shall be equal or less than $\pm 1\%$.

The cross tension force shall be measured during testing. The cross tension strength shall be determined from the maximum force value. All tests shall be carried out at room temperature.

The cross tension strength values obtained in accordance with this test shall be recorded, including type of failure mode and weld diameter for each weld in accordance with ISO 17677-1. See also [Clause 6](#).

A load-displacement diagram shall be created to give information about the deformation of the test specimen. An example of such a diagram is shown in [Figure 6](#).