



Designation: D 5009 – 96 (Reapproved 2002)

Standard Test Method for Evaluating and Comparing Transfer Efficiency of Spray Applied Coatings Under Laboratory Conditions¹

This standard is issued under the fixed designation D 5009; the number immediately following the designation indicates the year of original adoption or, in the case of revision, the year of last revision. A number in parentheses indicates the year of last reapproval. A superscript epsilon (ϵ) indicates an editorial change since the last revision or reapproval.

1. Scope

1.1 This test method covers the evaluation and comparison of the transfer efficiency of spray-applied coatings under controlled laboratory conditions.

1.2 This test method has been shown to yield excellent intralaboratory reproducibility. Interlaboratory precision is poorer and is highly dependent on closely controlled air flow in the spray booth, the rate at which the paint is delivered to the part, and other variables suggested in the test method.

1.3 Limitations:

1.3.1 This laboratory procedure only indicates the direction of the effect of spray variables on transfer efficiency. The magnitude of the effect is determined only by specific plant experience.

NOTE 1—This laboratory procedure requires specific equipment and procedures. For those laboratories that do not have access to the type of equipment required a more general laboratory procedure is being prepared as Procedure B.

1.4 The values stated in inch-pound units are to be regarded as the standard. The values given in parentheses are for information only.

1.5 *This standard does not purport to address all of the safety concerns, if any, associated with its use. It is the responsibility of the user of this standard to establish appropriate safety and health practices and determine the applicability of regulatory limitations prior to use.* For specific hazard statements, see Section 9 and Note 2 and Note 3.

2. Referenced Documents

2.1 ASTM Standards:

D 1200 Test Method for Viscosity by Ford Viscosity Cup²

D 2369 Test Method for Volatile Content of Coatings²

D 3925 Practice for Sampling Liquid Paints and Related Pigmented Coatings²

¹ This test method is under the jurisdiction of ASTM Committee D01 on Paint and Related Coatings, Materials, and Applications and is the direct responsibility of Subcommittee D01.55 on Factory Applied Coatings on Preformed Products.

Current edition approved Nov. 10, 1996. Published January 1997. Originally published as D 5009 – 89. Last previous edition D 5009 – 89.

² *Annual Book of ASTM Standards*, Vol 06.01.

2.2 National Fire Protection Association Documents³

NFPA 33 Spray Application Using Flammable and Combustible Materials

NFPA 86 Standard for Ovens and Furnaces

3. Terminology

3.1 Definitions of Terms Specific to This Standard:

3.1.1 *conveyor speed*—the speed of the conveyor in centimeters per minute during the test.

3.1.2 *fluid mass flow rate*—the mass flow rate of paint in grams per minute during the test.

3.1.3 *mass of foil*—the weight of each target foil in grams before being painted.

3.1.4 *mass of foil plus paint solids*—the weight of each target foil in grams after being painted and baked.

3.1.5 *mass of paint solids*—the difference in the mass of the foils before painting and the mass of the foils after painting and baking. This is the sum of the mass of the foil plus paint solids less the sum of the mass of the foil.

3.1.6 *transfer efficiency*—the ratio of the mass of the paint solids deposited on the foil to the mass of the paint solids sprayed during the test expressed as a percent.

3.1.7 *weight percent solids*—the solids content in percent of the total weight of a sample of the paint used during the test.

4. Summary of Test Method

4.1 Metal panels covered with preweighed aluminum foil are conveyed in a spraybooth past a fixed spraygun. The coated foils are then baked to remove volatile matter. The transfer efficiency is calculated on a weight basis using the solids content and quantity of the paint sprayed and the amount of solids on the coated aluminum foil target.

5. Significance and Use

5.1 Subject to the limitations listed above, the procedure can be used as a research tool to optimize spray equipment and paint formulations as well as to study the relative effect on

³ Available from National Fire Protection Assn., Batterymarch Park, Quincy, MA 02269-9101.

transfer efficiency of changing operating variables, spray application equipment, and types of coatings.

6. Apparatus

6.1 *Laboratory Scale*, accurate to ± 0.001 g for weight percent solids determination.

6.2 *Platform Scale*, accurate, or equivalent, to ± 0.01 g for mass of foil, mass of foil plus paint, and mass flow rate instrumentation calibration.

6.3 *Mass Flow Rate Meter*, or mass flow rate determination method, accurate to $\pm 2\%$ of the mass flow rate to be used during the test.

6.4 *Conveyor Timer* or conveyor timing method, accurate to $\pm 1\%$ of the conveyor speed to be used during the test. The equipment may consist of photoelectric cells or limit switches used in conjunction with a digital timer or timing marks on the conveyor used in conjunction with a stopwatch. Take at least two readings with a stopwatch and average the readings.

6.5 *Targets*, consisting of a set of ten steel panels 6 in. (15.2 cm) wide by 0.0625 in. (0.15875 cm) with 0.25-in. (0.635-cm) radius corners. A minimum panel length of 48 in. (121.9 cm) should be used. The length of the panel should be set so that a minimum of 12 in. (30.4 cm) above and below the spray pattern is achieved.

6.5.1 It is essential to do this so that the entire height of the spray pattern is effectively captured.

6.6 *Aluminum Foil*, medium temper or equivalent, 1.5 mil (0.0037 cm) thick.

6.7 *Back-Draw Water Wash Spray Booth*, or equivalent. The booth should be a minimum of 6 ft (1.8 m) wide and capable of up to 120 ft/min (0.61 m/s) air velocity in the middle at the plane of the target. If a dry filter booth is used, filters should be changed as necessary to maintain uniform air velocity.

6.8 *Adjustable Rate Overhead Conveyor System*, capable of hanging targets as specified, and capable of up to 40 ft/min (0.20 m/s) or the maximum speed desired by the user.

6.9 *Forced Draft Curing Oven*, of sufficient size for curing targets, and capable of achieving and maintaining the cure temperatures specified by the paint supplier. All ovens should conform to NFPA 86.

6.10 *Curing Rack*.

6.11 *Stopwatch*.

6.12 *Air Velocity Measurement Equipment*.

6.13 *Humidity and Temperature Measurement Equipment*.

6.14 *Compressed Air Supply*.

7. Hazards

7.1 For specific hazard information and guidance, consult the supplier's Material Safety Data Sheet (MSDS) for the materials used.

8. Procedure

8.1 Set up the spray apparatus paint supply and the mass flow measurement equipment in accordance with the manufacturer's instructions.

8.1.1 In accordance with Chapter 9-11 of NFPA 33, all electrically conductive objects in the spray area, except those objects required by the process to be at high voltage, shall be adequately grounded.

8.2 Agitate paint in a closed container at least 30 min before any paint samples are taken.

8.3 Using an airtight container take a paint grab sample from the paint pot in accordance with Practice D 3925.

8.4 Determine and record the following from the paint sample:

8.4.1 Viscosity determined in accordance with Test Method D 1200.

8.4.2 Weight percent solids determined in accordance with Test Method D 2369. If the baking temperature in Test Method D 2369 is inadequate, use the manufacturers recommended cure schedule.

8.4.3 Resistivity for the samples being applied electrostatically (An ASTM method is under development).

8.5 Set up the conveyor speed measuring equipment.

8.6 Cut the aluminum foil to dimensions of 15 in. (38 cm) by approximately 50 in. (127 cm) or 2 in. (5 cm) longer than the length of the target panel.

8.7 Consecutively number each precut foil strip before weighing using a permanent marking pen.

8.8 Weigh each test foil strip and record the uncoated weight and the foil number.

8.9 Attach the preweighed, labeled test foil to six targets using the technique shown in Fig. 1. Attach the unlabeled foil on four scavenger targets as shown in Fig. 1.

8.10 Mount the foil covered targets in consecutive order as shown in Fig. 2, with the foil seam on each target facing away from the spray gun.

8.10.1 If electrostatic equipment is being used the resistance shall be less than $1 \times 10^6 \Omega$ between the target and the earth ground in accordance with Chapter 9-8 of NFPA 33.

8.11 Adjust the following equipment operating parameters to the values desired for testing:

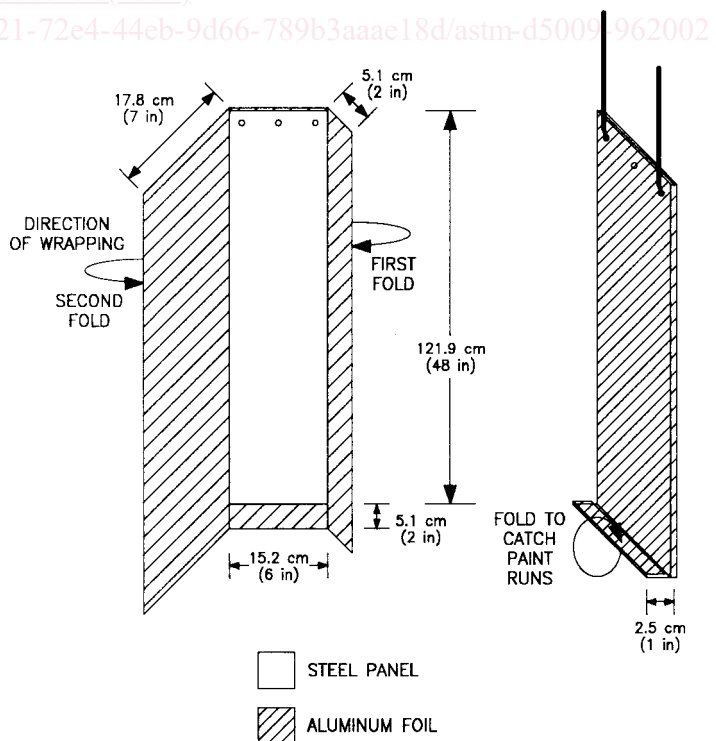

FIG. 1 Foil Attachment Technique