



Designation: E130 – 08

Standard Practice for Designation of Shapes and Sizes of Graphite Electrodes¹

This standard is issued under the fixed designation E130; the number immediately following the designation indicates the year of original adoption or, in the case of revision, the year of last revision. A number in parentheses indicates the year of last reapproval. A superscript epsilon (ϵ) indicates an editorial change since the last revision or reapproval.

1. Scope

1.1 This practice covers a number of specific graphite electrode shapes and sizes that are useful in spectrochemical analysis.

1.2 The values stated in inch-pound units are to be regarded as the standard. The values given in parentheses are for information only.

2. Referenced Documents

2.1 *ASTM Standards*:²

E135 Terminology Relating to Analytical Chemistry for Metals, Ores, and Related Materials

3. Terminology

3.1 For definitions of terms used in this practice, refer to Terminology E135.

3.2 *Definitions of Terms Specific to This Standard*:

3.2.1 *perform*—a descriptive word applied to a commercially produced spectroscopic electrode which is purified after machining.

4. Summary of Practice

4.1 The practice classifies electrodes by application and provides dimensional specifications.

5. Significance and Use

5.1 This practice is intended as a reference for spectrochemical methods that utilize graphite electrodes. Methods should employ and reference one of the electrode shapes in this practice, but if this is not possible, the method should include electrode specifications for the specific shape used.

5.2 This practice should be referred to in a method by including a statement such as the following in the section on Reagents and Materials:

¹ This practice is under the jurisdiction of ASTM Committee E01 on Analytical Chemistry for Metals, Ores, and Related Materials and is the direct responsibility of Subcommittee E01.20 on Fundamental Practices.

Current edition approved May 1, 2008. Published May 2008. Originally approved in 1957. Last previous edition approved in 2003 as E130 – 87 (2003). DOI: 10.1520/E0130-08.

² For referenced ASTM standards, visit the ASTM website, www.astm.org, or contact ASTM Customer Service at service@astm.org. For *Annual Book of ASTM Standards* volume information, refer to the standard's Document Summary page on the ASTM website.

Graphite Electrodes—The electrode(s) shall be of high-purity graphite and conform to type(s) (insert designation from this method) as depicted in Practice E130.

6. Classes

6.1 Seven classes of graphite electrodes are designated as follows:

6.1.1 *Class C—Counter Electrodes*, for use opposite the specimen or opposite the electrode that contains the specimen.

6.1.2 *Class S—Specimen Electrodes*, for use with liquid or particulate specimens. Thin-wall cups allow faster burn off of graphite and faster consumption of the specimen. Undercut cups provide greater heating of the specimen.

6.1.3 *Class P—Specimen Electrodes*, for use with nonconducting specimens or with specimens that require a center post that tends to stabilize the excitation.

6.1.4 *Class PC—Porous Cup Electrodes*, for use with liquid specimens only.

6.1.5 *Class D—Specimen Electrodes*, of disk shape for use with liquid specimens.

6.1.6 *Class VC and VCE—Vacuum Cups and Specimen Electrodes*, consisting of a tubular graphite electrode over which is positioned a tetrafluorethylene (TFE) cup which holds a liquid specimen.

6.1.7 *Class DCP—Electrodes*, for use as anodes on direct-current plasma spectrometers.

7. Dimensions

7.1 The dimensions of the electrodes of the various classes are given in Fig. 1. Unless exceptions are indicated, the following tolerances apply:

	±mm	±in.
Outside diameter	0.05	0.002
Length	0.41	0.016
Cavity, inside diameter	0.08	0.003
Cavity, depth	0.08	0.003
Neck, outside diameter	0.13	0.005
Neck, location	0.13	0.005
Neck, length	0.13	0.005
Concentricity, total indicator reading:		
Holes under 12.7 mm (0.5 in.) deep and undercuts	0.13	0.005
Holes over 12.7 mm (0.5 in.) deep	0.25	0.010
Rotating disks, inside diameter	0.03	0.001
Rotating disks, thickness	0.13	0.005
Boiler caps, inside diameter	0.02	0.001

Porous cups, bottom thickness:

Under 25.4 mm (1 in.) long

+0.05 +0.002

-0.00 -0.000

Over 25.4 mm (1 in.) long

+0.08 +0.003

-0.00 -0.000

Angle

±0.5°

Cavity, inside diameter

±mm

±in.

Cavity, depth

0.01

0.0005

Neck, outside diameter

0.05

0.002

Neck, location

0.05

0.002

Neck, length

0.08

0.003

Rod, outside diameter

0.03

0.001

7.2 Certain methods, such as those employing carrier distillation techniques, may require closer tolerances than those specified in 7.1. The following special tolerances will be exceptions to the normal tolerances when the suffix (X) is used along with the class designation. For example, S-12(X) designates the following exceptions to the normal tolerances:

8. Keywords

8.1 graphite electrodes; spectrometric analysis

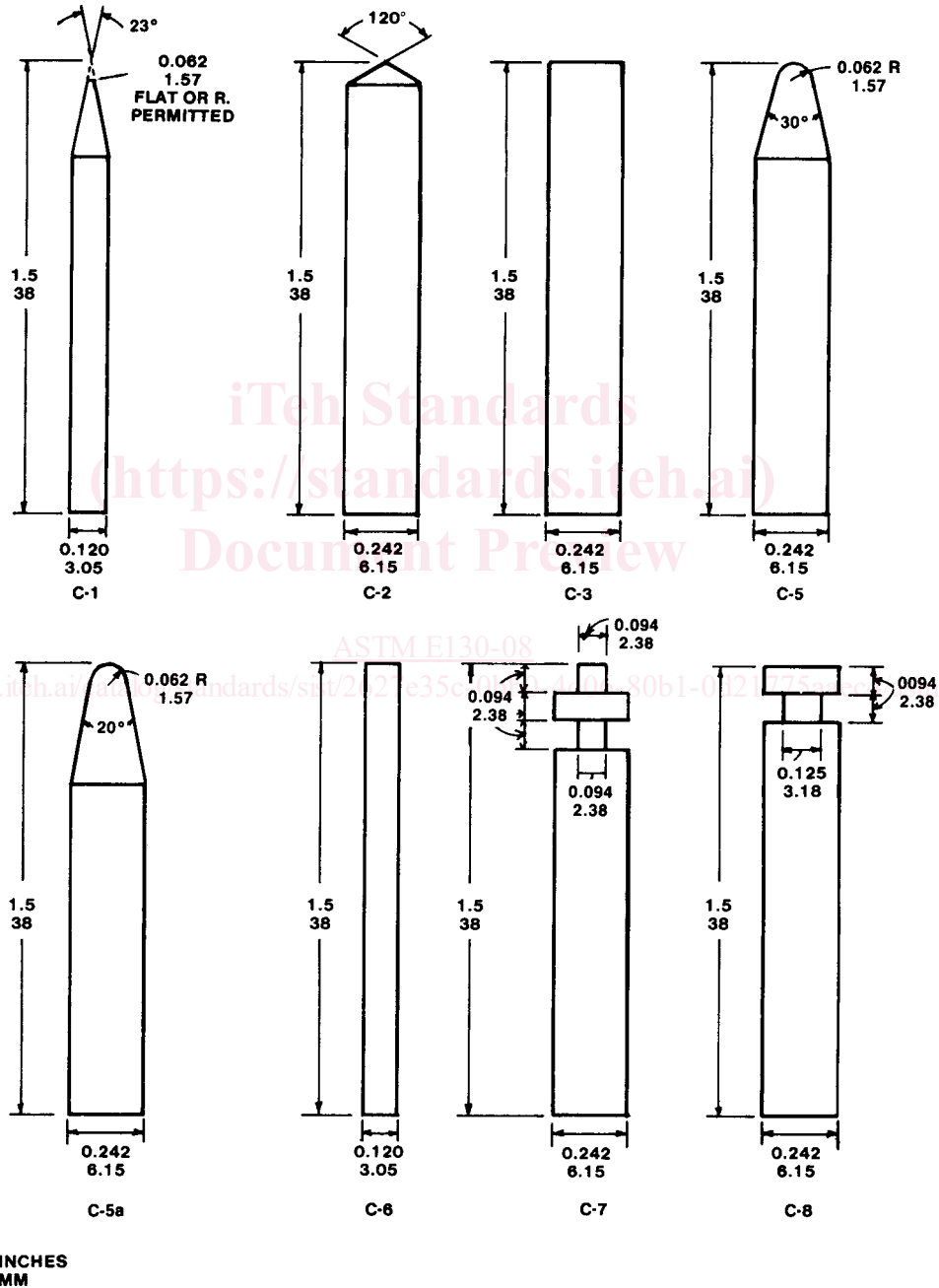
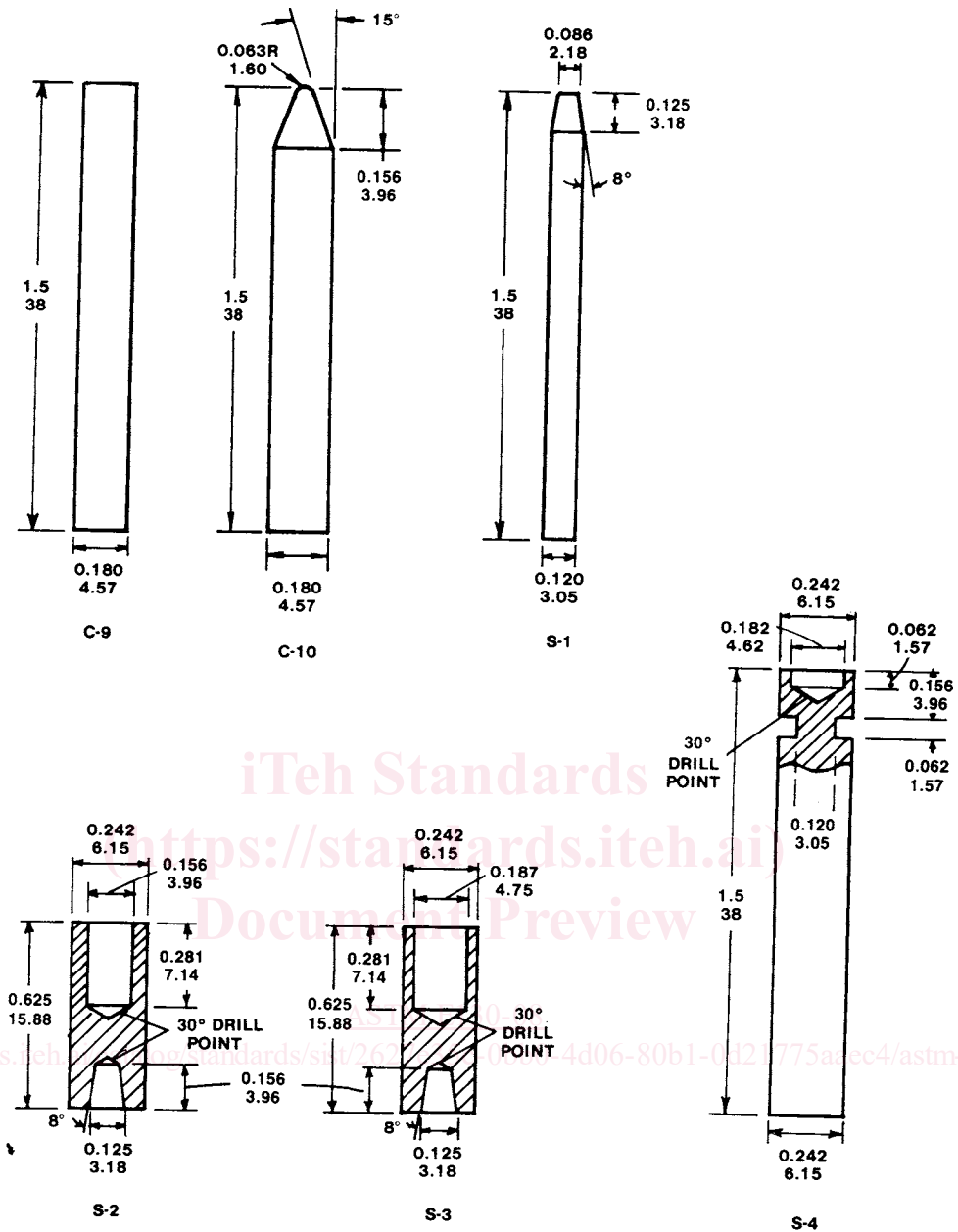

FIG. 1 Recommended Shapes and Sizes of Graphite Electrodes



INCHES
MM

FIG. 1 Recommended Shapes and Sizes of Graphite Electrodes (continued)

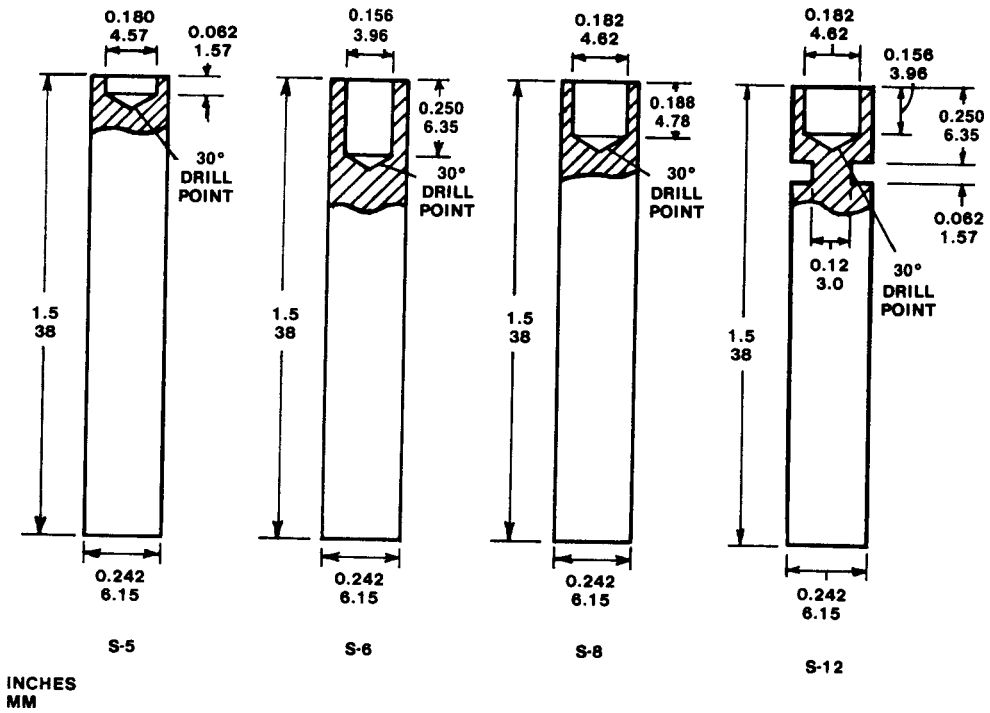

FIG. 1 Recommended Shapes and Sizes of Graphite Electrodes (continued)

iTeh Standards
 (https://standards.itih.ai)
 Document Preview

ASTM E130-08

https://standards.itih.ai/catalog/standards/sist/2627e35c-0bb0-4d06-80b1-0d21775aacc4/astm-e130-08

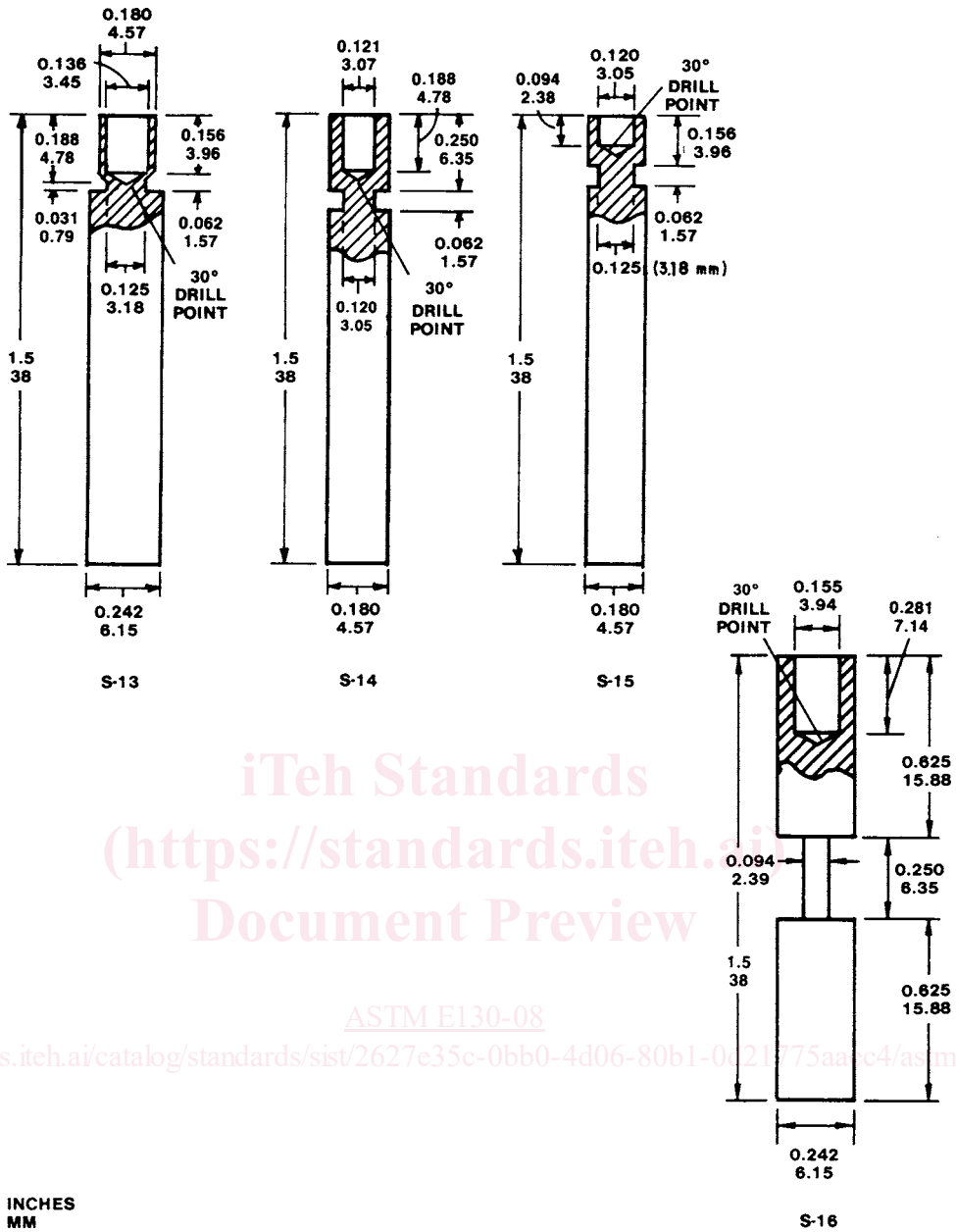
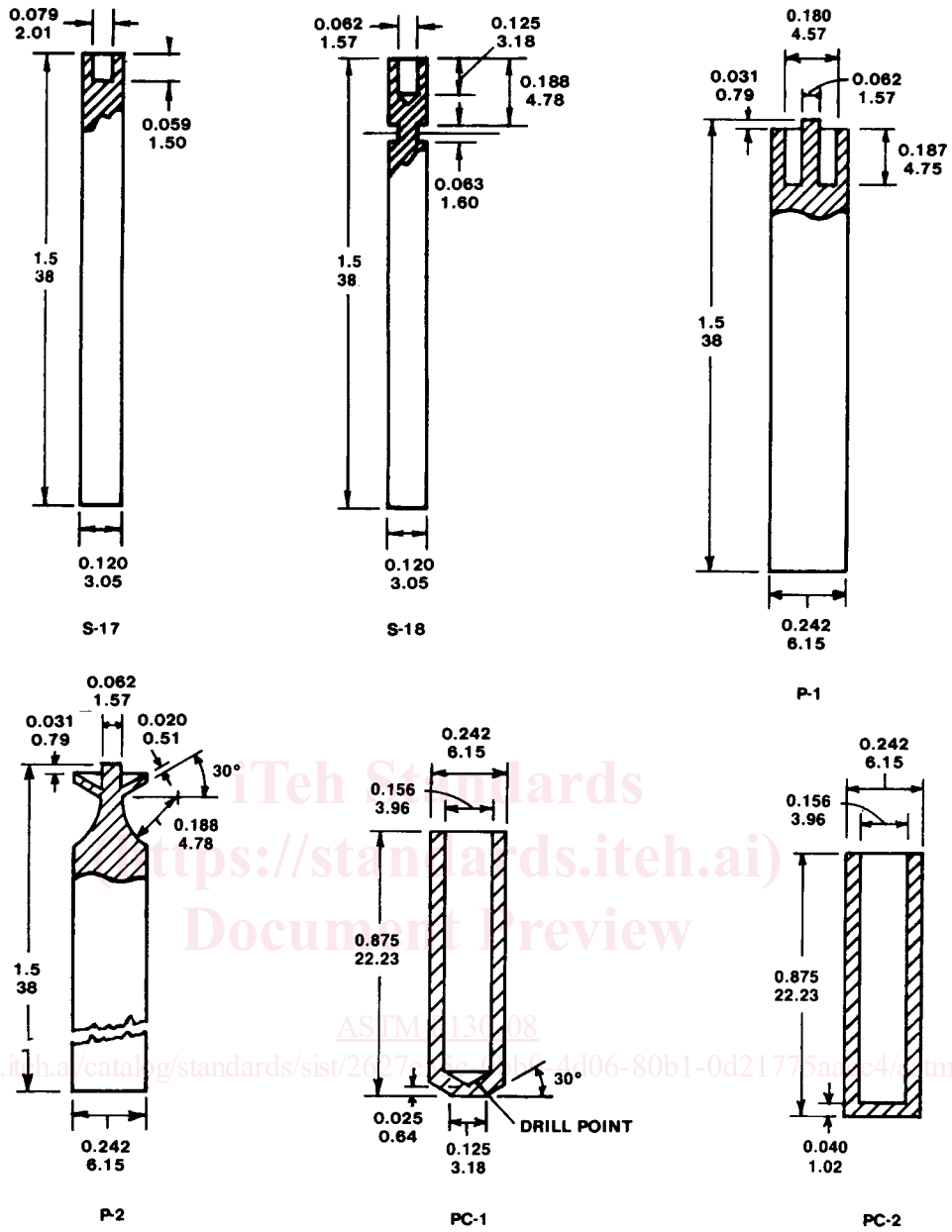

FIG. 1 Recommended Shapes and Sizes of Graphite Electrodes (continued)

INCHES
MM



INCHES
MM

FIG. 1 Recommended Shapes and Sizes of Graphite Electrodes (continued)