**Technical product documentation —
Edges of undefined shape —
Indication and dimensioning**

*Documentation technique de produits — Arêtes de forme non définie
— Indication et cotation*

iTeh STANDARD PREVIEW
(standards.iteh.ai)

[ISO 13715:2017](https://standards.iteh.ai/catalog/standards/sist/ab714607-7f29-4bfa-95b7-638f370707d0/iso-13715-2017)

<https://standards.iteh.ai/catalog/standards/sist/ab714607-7f29-4bfa-95b7-638f370707d0/iso-13715-2017>



iTeh STANDARD PREVIEW
(standards.iteh.ai)

ISO 13715:2017

<https://standards.iteh.ai/catalog/standards/sist/ab714607-7f29-4bfa-95b7-638f370707d0/iso-13715-2017>



COPYRIGHT PROTECTED DOCUMENT

© ISO 2017, Published in Switzerland

All rights reserved. Unless otherwise specified, no part of this publication may be reproduced or utilized otherwise in any form or by any means, electronic or mechanical, including photocopying, or posting on the internet or an intranet, without prior written permission. Permission can be requested from either ISO at the address below or ISO's member body in the country of the requester.

ISO copyright office
Ch. de Blandonnet 8 • CP 401
CH-1214 Vernier, Geneva, Switzerland
Tel. +41 22 749 01 11
Fax +41 22 749 09 47
copyright@iso.org
www.iso.org

Contents

	Page
Foreword	iv
Introduction	v
1 Scope	1
2 Normative references	1
3 Terms and definitions	1
4 Indications on drawings	4
4.1 Basic indication.....	4
4.2 Types of undefined edge.....	5
4.3 Size.....	5
4.4 Direction of passing or undercut.....	7
4.4.1 Indication in one direction.....	7
4.4.2 Asymmetrical indication.....	8
4.5 Location of the basic symbol.....	8
4.5.1 General.....	8
4.5.2 Individual indication of edges.....	9
4.5.3 Indication of limited areas.....	10
4.5.4 General indication of edges.....	11
4.5.5 Exceptions from general indications of edges.....	13
4.6 Reference to this document.....	15
Annex A (normative) Proportions and dimensions of graphical symbols	16
Annex B (informative) Examples of indication of undefined edges	18
Bibliography	22

[ISO 13715:2017](https://standards.iteh.ai/catalog/standards/sist/ab714607-7f29-4bfa-95b7-638f370707d0/iso-13715-2017)

<https://standards.iteh.ai/catalog/standards/sist/ab714607-7f29-4bfa-95b7-638f370707d0/iso-13715-2017>

Foreword

ISO (the International Organization for Standardization) is a worldwide federation of national standards bodies (ISO member bodies). The work of preparing International Standards is normally carried out through ISO technical committees. Each member body interested in a subject for which a technical committee has been established has the right to be represented on that committee. International organizations, governmental and non-governmental, in liaison with ISO, also take part in the work. ISO collaborates closely with the International Electrotechnical Commission (IEC) on all matters of electrotechnical standardization.

The procedures used to develop this document and those intended for its further maintenance are described in the ISO/IEC Directives, Part 1. In particular the different approval criteria needed for the different types of ISO documents should be noted. This document was drafted in accordance with the editorial rules of the ISO/IEC Directives, Part 2 (see www.iso.org/directives).

Attention is drawn to the possibility that some of the elements of this document may be the subject of patent rights. ISO shall not be held responsible for identifying any or all such patent rights. Details of any patent rights identified during the development of the document will be in the Introduction and/or on the ISO list of patent declarations received (see www.iso.org/patents).

Any trade name used in this document is information given for the convenience of users and does not constitute an endorsement.

For an explanation on the voluntary nature of standards, the meaning of ISO specific terms and expressions related to conformity assessment, as well as information about ISO's adherence to the World Trade Organization (WTO) principles in the Technical Barriers to Trade (TBT) see the following URL: www.iso.org/iso/foreword.html. (standards.iteh.ai)

This document was prepared by Technical Committee ISO/TC 10, *Technical product documentation*, Subcommittee SC 6, *Mechanical engineering documentation*.

This third edition cancels and replaces the second edition (ISO 13715:2000), which has been technically revised with the following changes:

- title changed from *Technical drawings — Edges of undefined shape — Vocabulary and indications to Technical product documentation — Edges of undefined shape — Indication and dimensioning*;
- Normative references updated;
- text rearranged in [Clause 4](#);
- figure titles changed;
- figures added and improved;
- [4.4.2](#) “Asymmetrical indications” added;
- Clause 5 deleted and Table 2 “Examples” is moved to [Annex B](#), explanations have been improved;
- [Annex B](#) “Recommended edge sixe” has been deleted, definition of sharp edge is deleted.

Introduction

In technical drawings, the ideal geometric shape is represented without any deviation and, in general, without consideration of the conditions of the edges. Nevertheless, for many purposes (the functioning of a part or out of safety considerations, for example) particular conditions of edges need to be indicated. Such conditions include those of external edges free from burr or those with a burr of limited size, and internal edges with a passing.

This document provides a symbology for the indication of the desired edge.

iTeh STANDARD PREVIEW (standards.iteh.ai)

[ISO 13715:2017](https://standards.iteh.ai/catalog/standards/sist/ab714607-7f29-4bfa-95b7-638f370707d0/iso-13715-2017)

<https://standards.iteh.ai/catalog/standards/sist/ab714607-7f29-4bfa-95b7-638f370707d0/iso-13715-2017>

iTeh STANDARD PREVIEW
(standards.iteh.ai)

ISO 13715:2017

<https://standards.iteh.ai/catalog/standards/sist/ab714607-7f29-4bfa-95b7-638f370707d0/iso-13715-2017>

Technical product documentation — Edges of undefined shape — Indication and dimensioning

1 Scope

This document specifies rules for the indication and dimensioning of undefined edges in technical product and dimensions. The proportions and dimensions of the graphical symbols to be used are also specified.

In cases where the geometrically defined shape of an edge (for example, $1 \times 45^\circ$) is required, the general dimensioning principles given in ISO 129-1 apply.

2 Normative references

There are no normative references cited in this document.

3 Terms and definitions

For the purposes of this document the following terms and definitions apply.

ISO and IEC maintain terminological databases for use in standardization at the following addresses:

— IEC Electropedia: available at <http://www.electropedia.org/>

— ISO Online browsing platform: available at <http://www.iso.org/obp>

3.1

edge of undefined shape

transition line, included in an intersection plane, which is not defined on the nominal model and which exists between two adjacent integral surfaces

3.2

undercut

deviation inside the ideal geometrical shape of an edge defined by two tangent outside straight lines to the adjacent feature of the zone of the undefined edge

Note 1 to entry: The explanation of the definition is given in [Figures 1](#) and [3](#). In order to simplify the illustration, only the undercut and the two tangents outside straight lines are represented.

Note 2 to entry: Examples are presented in [Figures 2](#) and [4](#).

3.3

passing

deviation outside the ideal geometrical shape of an edge defined by two tangent outside straight lines to the adjacent feature of the zone of the undefined edge

Note 1 to entry: The explanation of the definition is given in [Figures 5](#) and [7](#). In order to simplify the illustration, only the passing and the two tangents outside straight lines are represented.

Note 2 to entry: A burr or a flash (see [Figure 5](#)) can be considered to be a special case of external passing.

Note 3 to entry: Examples are presented in [Figures 6](#) and [8](#).

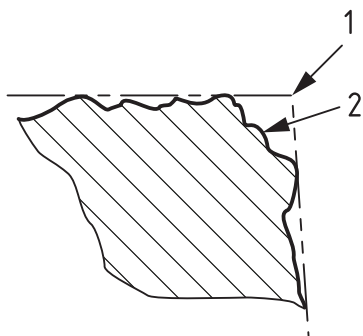

Key

- 1 ideal sharp edge
- 2 undercut

Figure 1 — Undercut on an external edge

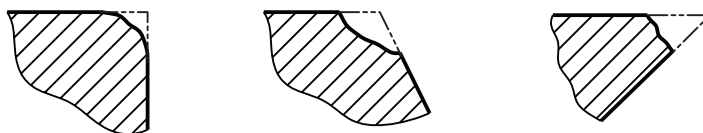
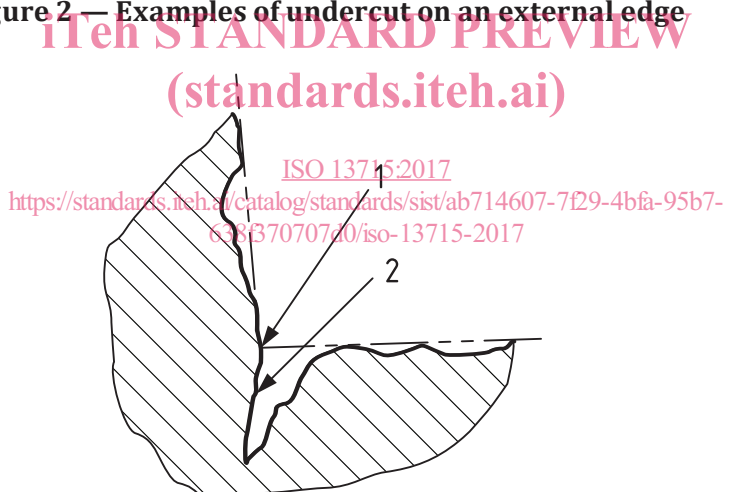

Figure 2 — Examples of undercut on an external edge



Key

- 1 ideal sharp edge
- 2 undercut

Figure 3 — Undercut on an internal edge

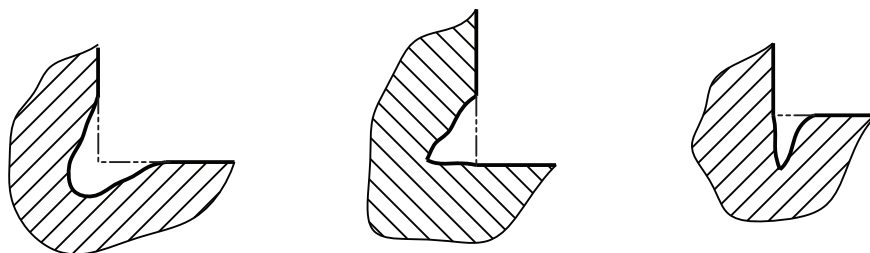
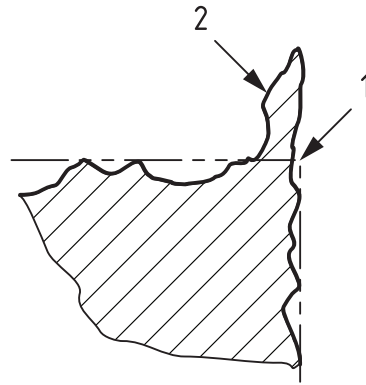

Figure 4 — Examples of undercut on an internal edge



Key

- 1 ideal sharp edge
- 2 passing

Figure 5 — Passing on an external edge (flash or burr)



Figure 6 — Examples of passing on external edge (burr or flash)

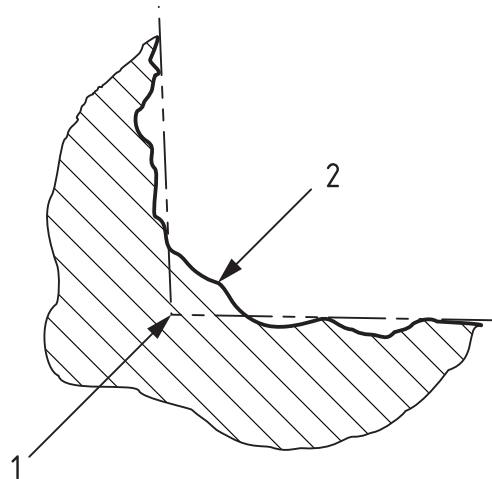

- Key**
- 1 ideal sharp edge
 - 2 passing

Figure 7 — Passing on an internal edge

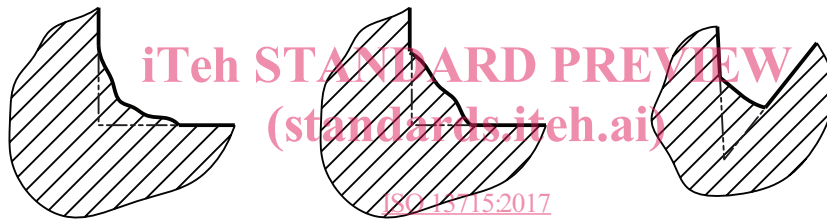

Figure 8 — Examples of passing on an internal edge

4 Indications on drawings

4.1 Basic indication

The requirements for an edge of a part shall be indicated by the basic graphical indication shown in [Figure 9](#). If all edges of a part are to be specified as undefined, the basic general indication is used (see [Figure 10](#)).

The graphical symbol and the specification shall be represented in such a way that they can be read from the bottom of the drawing.

The proportions of this symbol are given in [Annex A](#). Additional indications can be placed in the areas a₁, a₂ or a₃, see [Figure A.1](#).

Undefined edges cannot be described by the basic element alone. As a minimum indication, the type of undefined edge shall be specified.

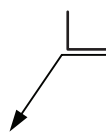

Figure 9 — Basic indication

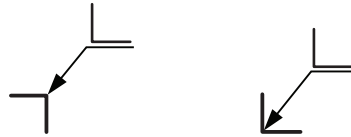

Figure 10 — Basic general indication

4.2 Types of undefined edge

The type of an undefined edge shall be indicated in the area a_1 (see Figure A.1), inside the basic symbol. The symbol element + (plus), - (minus) or \pm (plus or minus) is used in accordance with Table 1.

The symbol element + (plus) indicates permitted excess material, i.e. passing.

The symbol element - (minus) indicates required material removal, i.e. undercut.

The symbol element \pm (plus or minus) indicates permitted excess material or material removed, i.e. an undercut or a passing. This can only be used with an indication of size (see 4.3).

The deviation from ideal nominal shape can be controlled by indicating the size of passing and undercut (see 4.3) and the direction (see 4.4).

Table 1 — Symbols for the shapes of edges

Symbol	Meaning			
	External edge		Internal edge	
	Passing	Undercut	Passing	Undercut
 Can only be used with an indication of size.	Permitted	Not permitted	Permitted	Not permitted
	Not permitted	Required	Not permitted	Required
	Permitted	Permitted	Permitted	Permitted

4.3 Size

The maximum deviation of the undercut or passing shall be controlled by indication of the dimensions (size). The value is placed after the symbol element +, - or \pm in the area a_1 (see Figure A.1).

When a single limit for the size of an edge is specified with a positive value, the second limit deviation is the value zero; undercut is not permitted (see Figures 11 and 12).

When a single limit for the size of an edge is specified with a negative value, the second limit deviation is the value zero; passing is not permitted (see Figures 11 and 12).

Whenever the specification of an upper and lower limit deviation for the size of an edge is necessary, both values shall be indicated. The upper limit deviation is placed above the lower limit deviation (see Figure 13). The indicated limit deviations correspond to the maximum and minimum dimensions, respectively.

When a particular direction of passing or undercut is required, the indication shall be positioned accordingly (see 4.4).

NOTE The thickness of passing on external edges and the thickness of undercuts on internal edges cannot be specified according to this document.

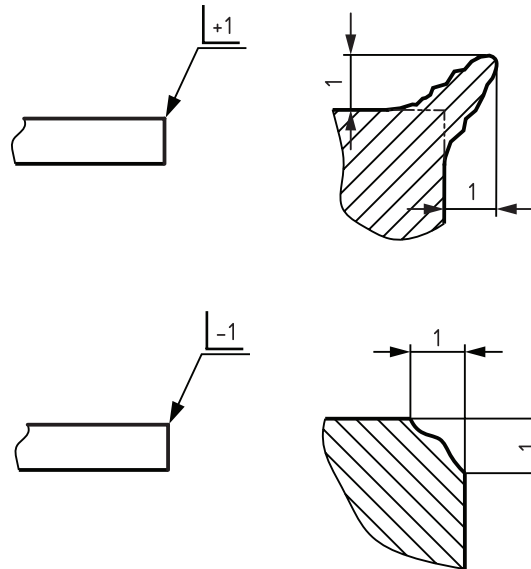

Figure 11 — Size of an external edges
(standards.iteh.ai)

ISO 13715:2017
<https://standards.iteh.ai/catalog/standards/sist/ab714607-7f29-4bfa-95b7-638f370707d0/iso-13715-2017>

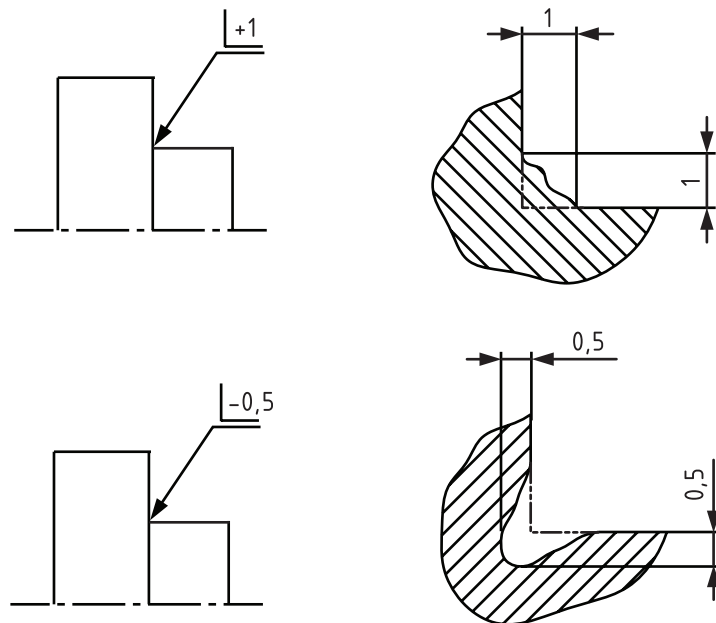

Figure 12 — Size of internal edges