**Water-cooled secondary connection
cables for resistance welding —**

**Part 3:
Test requirements**

Câbles secondaires refroidis par eau, pour le soudage par résistance —

Partie 3: Spécifications pour les essais

iTeh STANDARD PREVIEW
(standards.iteh.ai)

ISO 8205-3:2012

<https://standards.iteh.ai/catalog/standards/sist/73867ef4-c3de-4343-98f7-6af4d6a7d60a/iso-8205-3-2012>



iTeh STANDARD PREVIEW (standards.iteh.ai)

ISO 8205-3:2012

<https://standards.iteh.ai/catalog/standards/sist/73867ef4-c3de-4343-98f7-6af4d6a7d60a/iso-8205-3-2012>



COPYRIGHT PROTECTED DOCUMENT

© ISO 2012

All rights reserved. Unless otherwise specified, no part of this publication may be reproduced or utilized in any form or by any means, electronic or mechanical, including photocopying and microfilm, without permission in writing from either ISO at the address below or ISO's member body in the country of the requester.

ISO copyright office
Case postale 56 • CH-1211 Geneva 20
Tel. + 41 22 749 01 11
Fax + 41 22 749 09 47
E-mail copyright@iso.org
Web www.iso.org

Published in Switzerland

Foreword

ISO (the International Organization for Standardization) is a worldwide federation of national standards bodies (ISO member bodies). The work of preparing International Standards is normally carried out through ISO technical committees. Each member body interested in a subject for which a technical committee has been established has the right to be represented on that committee. International organizations, governmental and non-governmental, in liaison with ISO, also take part in the work. ISO collaborates closely with the International Electrotechnical Commission (IEC) on all matters of electrotechnical standardization.

International Standards are drafted in accordance with the rules given in the ISO/IEC Directives, Part 2.

The main task of technical committees is to prepare International Standards. Draft International Standards adopted by the technical committees are circulated to the member bodies for voting. Publication as an International Standard requires approval by at least 75 % of the member bodies casting a vote.

Attention is drawn to the possibility that some of the elements of this document may be the subject of patent rights. ISO shall not be held responsible for identifying any or all such patent rights.

ISO 8205-3 was prepared by Technical Committee ISO/TC 44, *Welding and allied processes*, Subcommittee SC 6, *Resistance welding and allied mechanical joining*.

This second edition cancels and replaces the first edition (ISO 8205-3:1993), which has been technically revised.

ISO 8205 consists of the following parts, under the general title *Water-cooled secondary connection cables for resistance welding*:

- Part 1: *Dimensions and requirements for double-conductor connection cables*
- Part 2: *Dimensions and requirements for single-conductor connection cables*
- Part 3: *Test requirements*

iTeH STANDARD PREVIEW
(standards.iteh.ai)
ISO 8205-3:2012
<https://standards.iteh.ai/catalog/standards/sist/73867ef4-c3de-4343-98f7-6af4d6a7d60a/iso-8205-3-2012>

iTeh STANDARD PREVIEW
(standards.iteh.ai)

ISO 8205-3:2012

<https://standards.iteh.ai/catalog/standards/sist/73867ef4-c3de-4343-98f7-6af4d6a7d60a/iso-8205-3-2012>

Water-cooled secondary connection cables for resistance welding —

Part 3: Test requirements

1 Scope

This part of ISO 8205 specifies test procedures for single- and double-conductor secondary connection cables used for resistance welding and allied processes. It stipulates the requirements regarding the electrical, mechanical, and cooling characteristics of these cables.

2 Normative references

The following referenced documents are indispensable for the application of this document. For dated references, only the edition cited applies. For undated references, the latest edition of the referenced document (including any amendments) applies.

ISO 8205-1, *Water-cooled secondary connection cables for resistance welding — Part 1: Dimensions and requirements for double-conductor connection cables*

ISO 8205-2, *Water-cooled secondary connection cables for resistance welding — Part 2: Dimensions and requirements for single-conductor connection cables*

ISO 8205-3:2012

<https://standards.iteh.ai/catalog/standards/sist/73867ef4-c3de-4343-98f7-6af4d6a7d60a/iso-8205-3-2012>

3 Tests

3.1 General

All the tests are type tests.

Figure 1 gives an example of the water supply to the cable for the tests requiring this.

When the tests are carried out, there shall be no trace of water at the various connections.

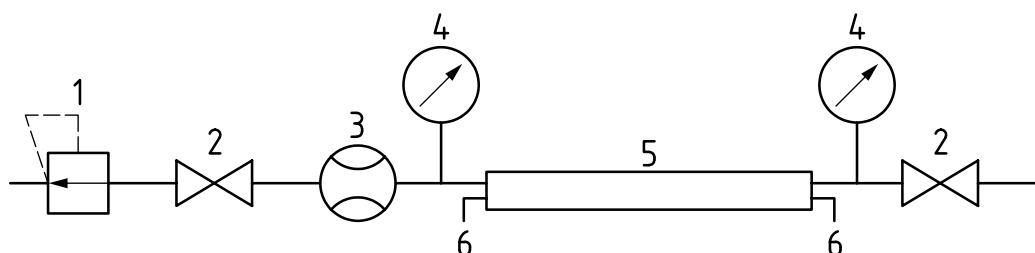

Key

1	pressure reducing valve	4	pressure gauge
2	valve	5	cable
3	flow meter	6	seal

Figure 1 — Example of water supply to the cable

3.2 Leak tightness and pressure resistance of the water circuit

Supply the water circuit, sealed downstream of the cable (e.g. by closing the valve on the right-hand side of Figure 1), under a pressure of 750 kPa (7,5 bar), e.g. by adjusting pressure-reducing valve 1, for 6 min.

3.3 Water flow

Carry out this test successively:

- with the cable laid flat out straight on a horizontal surface — see Figure 2 a);
- with the cable placed on a horizontal surface but bent with a radius of curvature of 300 mm — see Figure 2 b).

With the water circulating in the cable, e.g. by opening both valves (labelled 2) shown in Figure 1, adjust the pressure loss to 70 kPa (0,7 bar) for an upstream pressure greater than or equal to 100 kPa (1 bar).

Measure the water flow using a suitable flow transducer — see Figure 1, item 3.

3.4 Verification of flexibility at ends

3.4.1 General

Carry out this test on a low-reactance cable with a cross-sectional area of 200 mm² and length of 2 500 mm, considered to be representative of cables of the same design with a cross-sectional area or length as specified in ISO 8205-1 and ISO 8205-2.

iTeh STANDARD PREVIEW
(standards.iteh.ai)

3.4.2 Fixing of the cable

Fix the cable by one of its end lugs to a device fitted with horizontal and vertical graduated rules for measuring the coordinates of a point, in such a way that its other end hangs free — see Figure 3.

Carry out the test for each of the two ends of the cable.

ISO 8205-3
<https://standards.iteh.ai/catalog/standards/sist/73867ef4-c3de-4343-98f7-01140a180a/iso-8205-3-2012>

3.4.3 Measurements to be taken

Using the two graduated rules, measure the ordinate y at each of the points A, B and C with x equal to 0 mm, 150 mm, and 300 mm, respectively. The origin A of the coordinates is the point of intersection of the axis of the fixing hole in the end lug with its median plane; points B and C are located on the axis of the cable — see Figure 3.

3.4.4 Interpretation of results

Determine the arc of the circle passing through the three points A, B, and C by geometrical construction. The radius of the arc shall be regarded as the radius of curvature — see Figure 3 b).

NOTE If the ordinate of point C is greater than 0,30 m, the radius of curvature is regarded as being less than 0,30 m provided that the ordinate of point B is different from 0.

3.5 Torsion

3.5.1 General

Carry out this test on low-reactance cable with a cross-sectional area of 200 mm² and length of 1 250 mm, regarded as being representative of cables of the same design having a cross-sectional area and length as specified in ISO 8205-1.

3.5.2 Test rig

See Figure 4.

Suspend the cable vertically, with the end lug by which it is suspended, immobilized as regards rotational and translational motion. Apply a force of $500 \text{ N} \pm 50 \text{ N}$ to the lower lug of the cable by means of a rotating fork coupling and a pressure cylinder. Fill the cable with water at a pressure of 150 kPa (1,5 bar).

3.5.3 Measurement to be taken

Measure the torque required to effect a 180° rotation in each direction of the lower lug.

3.6 Measurement of insulation resistance

Measure the insulation resistance of a new dry cable following application of a d.c. voltage of 48 V for 1 min.

3.7 Determination of the impedance of the cable (only for cables in accordance with ISO 8205-1)

Determine the impedance of the cable at 30°C by applying to its terminals an alternating voltage, as sinusoidal as possible, of frequency 50 Hz or 60 Hz, r.m.s value, U , and measuring, by means of a calibrated toroid, the intensity, I , of the current circulating in the cable. The impedance, Z , is then given by

$$Z = \frac{U}{I}$$

3.8 Determination of the resistance of the cable

Determine the resistance of the cable at 30°C and with no water in the cable, by applying to its terminals a permanent voltage, U , and measuring the intensity, I , of the current circulating in the cable. The resistance, R , is then given by

$$R = \frac{U}{I}$$

ISO 8205-3:2012
<https://standards.iteh.ai/catalog/standards/sist/73867ef4-c3de-4343-98f7-6af4d6a7d60a/iso-8205-3-2012>

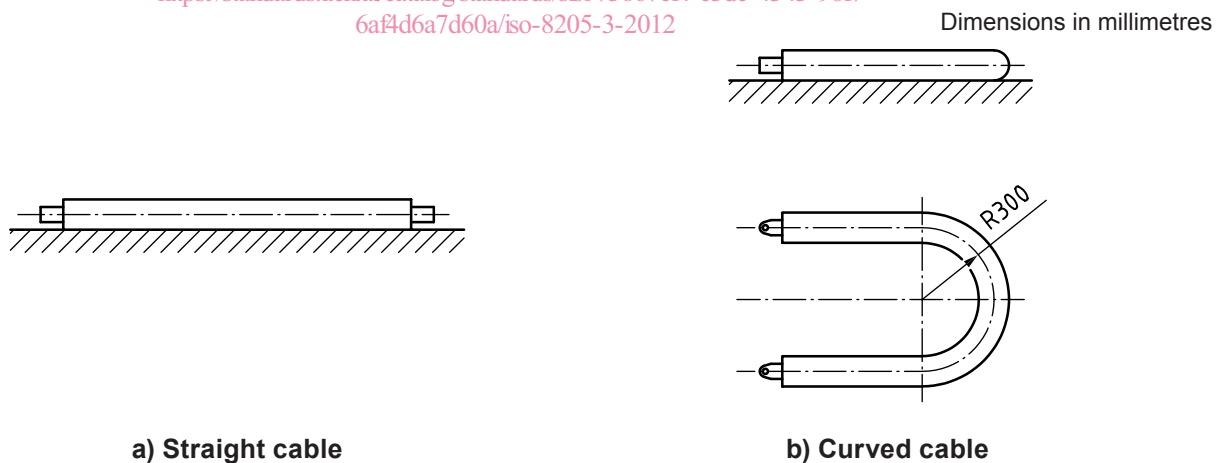

Figure 2 — Verification of water flow

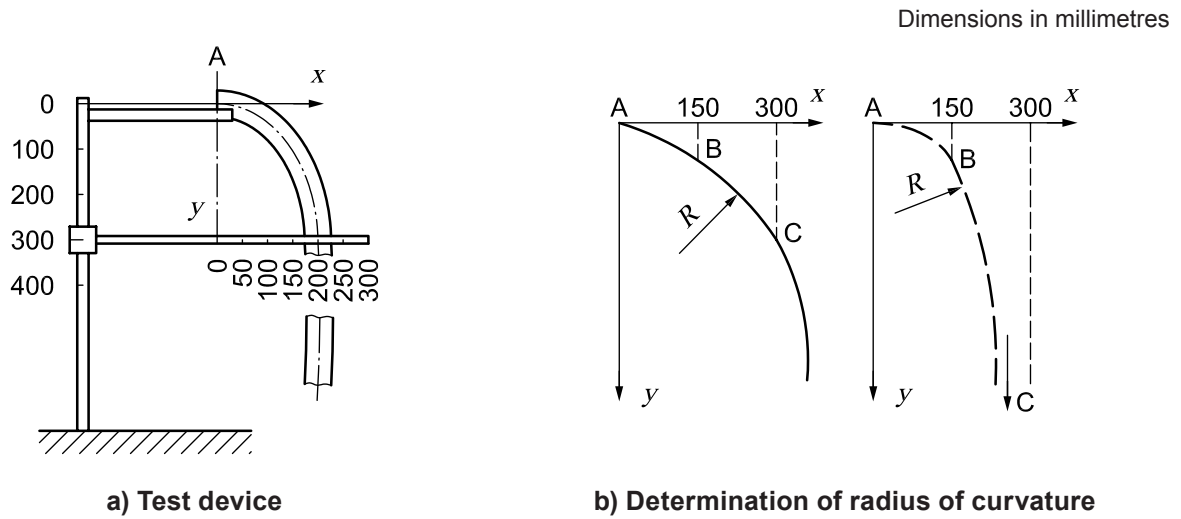
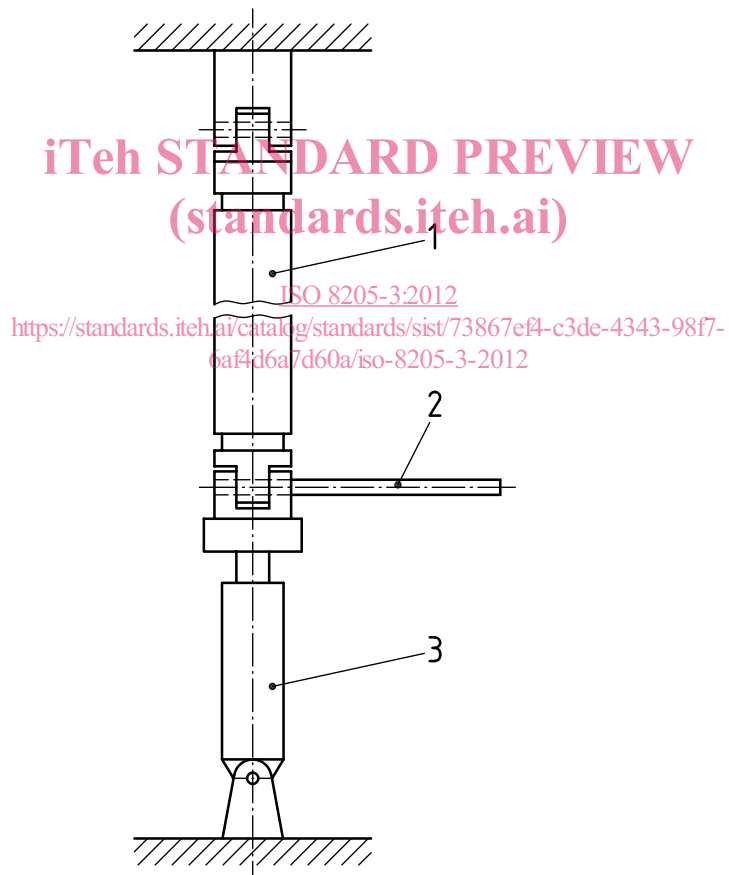

Figure 3 — Measurement of radius of curvature



Key

- 1 cable
- 2 elastic proving device
- 3 cylinder — tensile load, 500 N

Figure 4 — Rig for torsion test

3.9 Calculation of $\cos \phi$ (only for cables in accordance with ISO 8205-1)

The value of $\cos \phi$ for the cable can then be calculated by using the values obtained in 3.7 and 3.8 as follows:

$$\cos \phi = \frac{R}{Z}$$

3.10 Endurance test

3.10.1 Principle

Estimation of the life of a type of low-reactance cable and the variation in time of its electrical resistance.

The cable is fixed to a test device which enables the displacements, tilting and twisting likely to occur in normal service to be reproduced and is supplied by a welding transformer and cooled. It is then subjected to a series of cycles comprising a fixed number of the various possible movements and pulse currents (referred to below as welding duration and current).

This type test shall be carried out on the length stated in Table 1.

Table 1 — Adjustment parameters for 2 500 mm long cables

Cross-sectional area of cable mm ²	Current kA	Duration of application of current s	Number of current pulses per minute	Duty ratio %	Duration of one welding cycle s	Duration of test cycle s
160	16	0,24	13	5,2	4,6	145
200	19	0,4	13	8,6	4,6	145
250	19	0,4	15	10	4	127
315	24	0,5	10	8,3	6	187

3.10.2 Test apparatus

Figure 5 gives an example of the test apparatus.

3.10.3 Adjustment parameters

The test shall be carried out on a 2 500 mm long cable. The adjustment parameters given in Table 1 for the various cross-sectional areas shall be used.

The cooling circuit shall be adjusted so as to obtain a pressure loss of 70 kPa (0,7 bar).

3.10.4 Test cycle

Each test cycle shall have the duration specified in Table 1 and shall comprise:

- one forward movement of the carriage over a distance of 700 mm;
- 15 torsional cycles consisting of a 90° twist in one direction, return to the initial position, a 90° twist in the opposite direction, and return to the initial position;
- 10 forward tilting movements over an angle of 90° followed by tilting in the opposite direction to return to the initial position;
- 30 applications of current for the duration specified in Table 1;
- one backward displacement of the carriage returning it to its initial position.