



**SLOVENSKI STANDARD**  
**SIST EN ISO 11200:2014/oprA1:2017**  
**01-maj-2017**

---

**Akustika - Emisija hrupa strojev in naprav - Smernice za uporabo temeljnih standardov za ugotavljanje emisijskih ravni zvočnega tlaka na mestu delovanja in na drugih opredeljenih mestih - Dopolnilo A1 (ISO 11200:2014/DAmD 1:2017)**

Acoustics - Noise emitted by machinery and equipment - Guidelines for the use of basic standards for the determination of emission sound pressure levels at a work station and at other specified positions - Amendment 1 (ISO 11200:2014/DAmD 1:2017)

Akustik - Geräuschabstrahlung von Maschinen und Geräten - Leitlinien zur Anwendung der Grundnormen zur Bestimmung von Emissions-Schalldruckpegeln am Arbeitsplatz und an anderen festgelegten Orten - Änderung 1 (ISO 11200:2014/ DAmD 1:2017)

Acoustique - Bruit émis par les machines et équipements - Guide d'utilisation des normes de base pour la détermination des niveaux de pression acoustique d'émission au poste de travail et en d'autres positions spécifiées - Amendement 1 (ISO 11200:2014/DAmD 1:2017)

**Ta slovenski standard je istoveten z: EN ISO 11200:2014/prA1**

---

**ICS:**

17.140.20	Emisija hrupa naprav in opreme	Noise emitted by machines and equipment
-----------	--------------------------------	---

**SIST EN ISO 11200:2014/oprA1:2017** en



# DRAFT AMENDMENT

## ISO 11200:2014/DAM 1

ISO/TC 43/SC 1

Secretariat: DIN

Voting begins on:  
2017-01-20Voting terminates on:  
2017-04-13

---

---

### Acoustics — Noise emitted by machinery and equipment — Guidelines for the use of basic standards for the determination of emission sound pressure levels at a work station and at other specified positions

#### AMENDMENT 1

*Acoustique — Bruit émis par les machines et équipements — Guide d'utilisation des normes de base pour la détermination des niveaux de pression acoustique d'émission au poste de travail et en d'autres positions spécifiées*

*AMENDEMENT 1*

ICS: 17.140.20

THIS DOCUMENT IS A DRAFT CIRCULATED FOR COMMENT AND APPROVAL. IT IS THEREFORE SUBJECT TO CHANGE AND MAY NOT BE REFERRED TO AS AN INTERNATIONAL STANDARD UNTIL PUBLISHED AS SUCH.

IN ADDITION TO THEIR EVALUATION AS BEING ACCEPTABLE FOR INDUSTRIAL, TECHNOLOGICAL, COMMERCIAL AND USER PURPOSES, DRAFT INTERNATIONAL STANDARDS MAY ON OCCASION HAVE TO BE CONSIDERED IN THE LIGHT OF THEIR POTENTIAL TO BECOME STANDARDS TO WHICH REFERENCE MAY BE MADE IN NATIONAL REGULATIONS.

RECIPIENTS OF THIS DRAFT ARE INVITED TO SUBMIT, WITH THEIR COMMENTS, NOTIFICATION OF ANY RELEVANT PATENT RIGHTS OF WHICH THEY ARE AWARE AND TO PROVIDE SUPPORTING DOCUMENTATION.

This document is circulated as received from the committee secretariat.

**ISO/CEN PARALLEL PROCESSING**



Reference number  
ISO 11200:2014/DAM 1:2017(E)

© ISO 2017

**ISO 11200:2014/DAM 1:2017(E)**



**COPYRIGHT PROTECTED DOCUMENT**

© ISO 2017, Published in Switzerland

All rights reserved. Unless otherwise specified, no part of this publication may be reproduced or utilized otherwise in any form or by any means, electronic or mechanical, including photocopying, or posting on the internet or an intranet, without prior written permission. Permission can be requested from either ISO at the address below or ISO's member body in the country of the requester.

ISO copyright office  
Ch. de Blandonnet 8 • CP 401  
CH-1214 Vernier, Geneva, Switzerland  
Tel. +41 22 749 01 11  
Fax +41 22 749 09 47  
copyright@iso.org  
www.iso.org

## Foreword

ISO (the International Organization for Standardization) is a worldwide federation of national standards bodies (ISO member bodies). The work of preparing International Standards is normally carried out through ISO technical committees. Each member body interested in a subject for which a technical committee has been established has the right to be represented on that committee. International organizations, governmental and non-governmental, in liaison with ISO, also take part in the work. ISO collaborates closely with the International Electrotechnical Commission (IEC) on all matters of electrotechnical standardization.

The procedures used to develop this document and those intended for its further maintenance are described in the ISO/IEC Directives, Part 1. In particular the different approval criteria needed for the different types of ISO documents should be noted. This document was drafted in accordance with the editorial rules of the ISO/IEC Directives, Part 2 (see [www.iso.org/directives](http://www.iso.org/directives)).

Attention is drawn to the possibility that some of the elements of this document may be the subject of patent rights. ISO shall not be held responsible for identifying any or all such patent rights. Details of any patent rights identified during the development of the document will be in the Introduction and/or on the ISO list of patent declarations received (see [www.iso.org/patents](http://www.iso.org/patents)).

Any trade name used in this document is information given for the convenience of users and does not constitute an endorsement.

For an explanation on the meaning of ISO specific terms and expressions related to conformity assessment, as well as information about ISO's adherence to the World Trade Organization (WTO) principles in the Technical Barriers to Trade (TBT) see the following URL: [www.iso.org/iso/foreword.html](http://www.iso.org/iso/foreword.html).

The committee responsible for this document is ISO/TC 43, *Acoustics*, Subcommittee SC 1, *Noise*.



# Acoustics — Noise emitted by machinery and equipment — Guidelines for the use of basic standards for the determination of emission sound pressure levels at a work station and at other specified positions

## AMENDMENT 1

Page 2, Clause 2

Add “:1995” after ISO 11203, so that the referred document is dated and read fully as:

ISO 11203:1995, *Acoustics — Noise emitted by machinery and equipment — Determination of emission sound pressure levels at a work station and at other specified positions from the sound power level*

Page 11, Clause 5

Delete the following first two lines of the text:

“Overview of the methods offered in the ISO 11201, ISO 11202, ISO 11203, ISO 11204 and ISO 11205 group for determining the emission sound pressure level at work stations and other specified positions”.

Page 24, A.2, 2nd line

Replace “<” by “≤” in “ $K_{2A} < 7$  dB”.

Page 26, Figure B.1

Replace both figures B.1 a) and B.1 b) by the following figures:

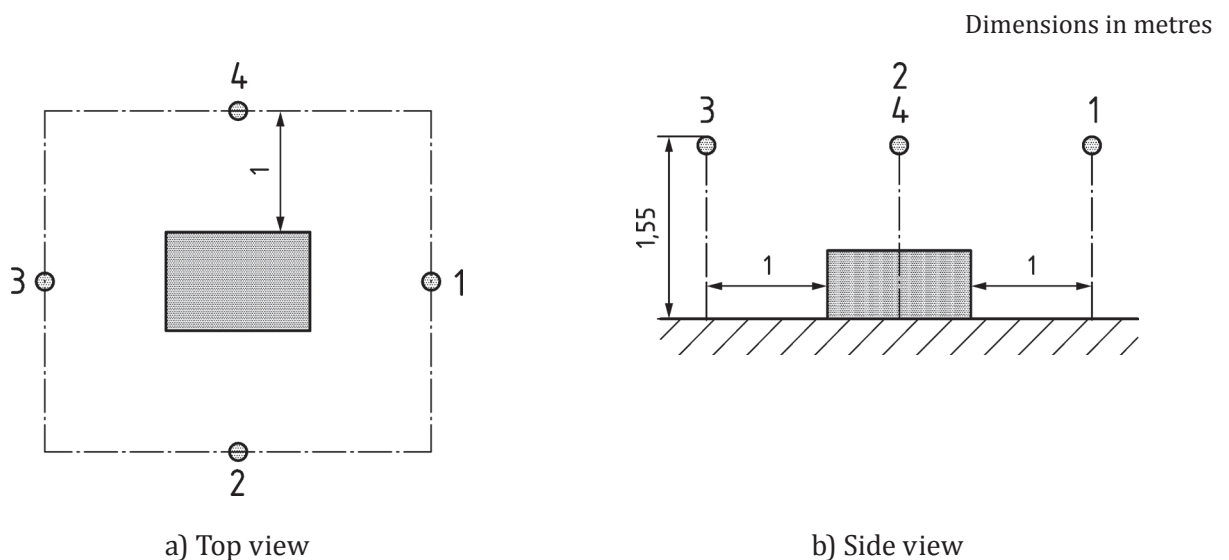

### Key

● microphone positions

The grey box depicts the reference box.

**Figure B.1 — Top and side views of machine and microphone positions**

## ISO 11200:2014/DAM 1:2017(E)

Page 28, Figure B.2

Replace Figure B.2 by the following figure:

Dimensions in metres

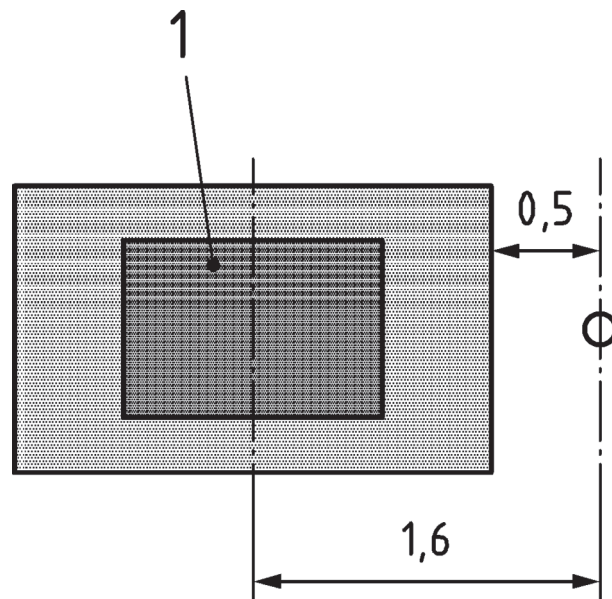
**Key**

- 1 dominating source
  - microphone position at the workstation
- The grey box depicts the reference box

**Figure B.2 — Top view of the machine showing the workstation position**