

# International Standard



# 1559

INTERNATIONAL ORGANIZATION FOR STANDARDIZATION • МЕЖДУНАРОДНАЯ ОРГАНИЗАЦИЯ ПО СТАНДАРТИЗАЦИИ • ORGANISATION INTERNATIONALE DE NORMALISATION

## Dentistry — Alloys for dental amalgam

*Art dentaire — Alliages pour amalgame dentaire*

**Second edition — 1986-06-15**

**iTeh STANDARD PREVIEW**  
**(standards.iteh.ai)**

[ISO 1559:1986](https://standards.iteh.ai/catalog/standards/sist/da5153c2-dc1b-4f6e-8a8b-fb3c38313869/iso-1559-1986)

<https://standards.iteh.ai/catalog/standards/sist/da5153c2-dc1b-4f6e-8a8b-fb3c38313869/iso-1559-1986>

**UDC 616.314 : 615.462**

**Ref. No. ISO 1559-1986 (E)**

**Descriptors :** dentistry, dental materials, amalgams, silver alloys, specifications, tests, packing, marking, test equipment.

Price based on 4 pages

## Foreword

ISO (the International Organization for Standardization) is a worldwide federation of national standards bodies (ISO member bodies). The work of preparing International Standards is normally carried out through ISO technical committees. Each member body interested in a subject for which a technical committee has been established has the right to be represented on that committee. International organizations, governmental and non-governmental, in liaison with ISO, also take part in the work.

Draft International Standards adopted by the technical committees are circulated to the member bodies for approval before their acceptance as International Standards by the ISO Council. They are approved in accordance with ISO procedures requiring at least 75 % approval by the member bodies voting.

International Standard ISO 1559 was prepared by Technical Committee ISO/TC 106, *Dentistry*.

This second edition cancels and replaces the first edition (ISO 1559-1978), of which it constitutes a technical revision (see clause 0).

Users should note that all International Standards undergo revision from time to time and that any reference made herein to any other International Standard implies its latest edition, unless otherwise stated.

**iTeh STANDARD PREVIEW**  
**(standards.iteh.ai)**

<https://standards.iteh.ai/catalog/standards/sist/da5153c2-dc1b-4f6e-8a8b-fb3c38313869/iso-1559-1986>

# Dentistry — Alloys for dental amalgam

## 0 Introduction

This International Standard was first published in 1978 and was based on International Dental Federation (FDI) Specification No. 1. It was then the subject of a planned programme of revision to bring it up to date on the basis of technical data provided by both ISO/TC 106 and the FDI. Of the various changes introduced in this second edition, the more significant are

- the updating of the composition requirements to include alloys with high copper contents;
- the inclusion of an all-mechanical, two-thrust method for preparing test specimens;
- the modification of the requirements for dimensional change during hardening;
- the modification of the test methods for determining creep and compressive strength;
- the addition of a 24 h compressive strength requirement;
- a statement by the manufacturer as regards marking which lists all elements present in the chemical composition over 0,1 % (m/m); and
- a description by the manufacturer of the particle shape or shapes.

It is proposed to include a corrosion test requirement for dental amalgam at the earliest possible date. Such a test may include ion release or gravimetric loss of substance after leaching completely hardened amalgam specimens in a suitable corrosion solution.

## 1 Scope and field of application

This International Standard specifies requirements and methods of test for alloys composed mainly of silver, tin and copper, complying with the composition requirements (see 4.1) in either the powder or tablet form, suitable for the preparation of dental amalgam.

## 2 References

ISO 286, *ISO system of limits and fits*.<sup>1)</sup>

ISO 468, *Surface roughness — Parameters, their values and general rules for specifying requirements*.

ISO 1560, *Dental mercury*.

ISO/TR 7405, *Biological evaluation of dental materials*.

## 3 Definition

**alloy for dental amalgam:** An alloy in fine particles, composed mainly of silver, tin and copper, which, when mixed with mercury, produces a dental amalgam.

## 4 Requirements

### 4.1 Chemical composition

#### 4.1.1 General

The chemical composition of the alloy shall comply with table 1.

The total contamination by other non-noble metals shall not exceed 0,1 %.

Table 1 — Chemical composition requirements

Metal	Content % (m/m)
Silver	40 min.
Tin	32 max.
Copper	30 max.
Zinc	2 max.
Mercury	3 max.

#### 4.1.2 Deviations in chemical composition

Metals other than those specified in 4.1.1 are permitted to replace parts of tin and copper provided that the manufacturer presents adequate evidence of clinical and biological investigations in accordance with ISO/TR 7405 to show that the alloy with the deviation in composition is safe to use in the mouth.

1) At present at the stage of draft. (Revision of ISO/R 286-1962.)

**4.2 Presentation**

The alloy may be in powder or tablet form or in capsules containing pre-weighed portions of alloy and mercury. A statement shall accompany the capsules to the effect that they contain mercury complying with the requirements of ISO 1560.

**4.3 Physical properties**

When tested in accordance with 6.2, 6.3 and 6.4, the material shall comply with the requirements given in table 2.

**Table 2 – Physical properties**

Creep %	Dimensional change %	Compressive strength	
		after 1 h	after 24 h
max.		MPa	
		min.	min.
3,0	-0,1 to + 0,2	50	300

**4.4 Mass**

When tested in accordance with 6.5, the mass of the alloy tablets, or, in the case of pre-dosed capsules, the mass of both the alloy and the mercury, shall have a coefficient of variation not greater than 1,5 %.

**4.5 Loss from capsule**

For alloys supplied in capsules, the average loss in mass per capsule during amalgamation shall not exceed 0,5 mg when tested in accordance with 6.6.

**5 Sample size**

At least 50 g of alloy shall be procured.

**6 Test methods**

**6.1 Preparation of test specimens**

Prepare all test specimens and carry out all tests at  $23 \pm 2$  °C, unless otherwise specified by the manufacturer.

**6.1.1 Amalgamation**

Mechanically amalgamate a sample of  $0,600 \pm 0,005$  g of alloy with the mass of mercury specified by the manufacturer as optimum for that alloy using equipment specified by the manufacturer in accordance with 7.3 b).

Powder the tablets by placing two tablets in a capsule-pestle combination recommended by the manufacturer for preparing the amalgam. Mechanically amalgamate this mass for 2 s or until sufficiently powdered to permit weighing the 0,600 g of alloy.

**6.1.2 Preparation of the test specimens for determination of creep, dimensional change and compressive strength**

Use an all-mechanical method. Assemble the holder, spacers Nos. 1 and 2, the die and plunger No. 1 with the cap in position or plunger No. 3 as shown in the figure. The holder, spacers and cap shall be made of cold-rolled or stainless steel. The die and plungers shall be made of hardened tool or hardened stainless steel. The cap and plunger No. 1 are used when the dimensional change specimens are measured in an interferometer. The working surfaces of the die and plungers shall be honed surfaces, with an  $R_a$  surface roughness value of  $6,3 \mu\text{m}$ , in accordance with ISO 468. Limits of clearance for the die and plungers should be F7/h7, in accordance with ISO 286.

Empty the coherent mass of amalgamated material on top of the cavity of the die and immediately insert in the mould with several thrusts of an amalgam condenser slightly less than 4 mm in diameter. Do not express mercury during the insertion. Insert plunger No. 2 and follow the time schedule in table 3.

**Table 3 – Schedule for preparation of test specimens**

Procedure	Time, s
End of amalgamation	00
Place amalgamated mass in mould and apply pressure of 14 MPa	30
Release load and remove No. 2 spacer at	45
Replace load at	50
Release load at	90
Carefully remove excess mercury and eject specimen at	120

Do not trim the specimen.

Transfer the specimens to an environment maintained at  $37 \pm 1$  °C.

**6.2 Determination of creep after 7 days**

**6.2.1 Preparation of test specimens**

Take three specimens prepared in accordance with 6.1 using plungers Nos. 2 and 3 (see the figure). Store the specimens at  $37 \pm 1$  °C for 7 days. Prior to testing, prepare the surface of both ends of each specimen plane and perpendicular to the axis with wet 600 grit size silicon carbide papers. Measure the length of each specimen and record it to the nearest 0,01 mm.

**6.2.2 Procedure**

Axially apply a stress of  $36 \pm 0,2$  MPa continuously to the specimen for not less than 4 h at  $37 \pm 0,5$  °C. Record the change in length between the 1 h and 4 h reading and calculate the creep, expressed as a percentage, as follows:

$$\text{Creep} = \frac{\text{change in length between 1 h and 4 h}}{\text{original length}} \times 100$$

Record, to the nearest 0,1 %, the average value of the creep for the three specimens.

### 6.3 Determination of dimensional change during hardening

#### 6.3.1 Preparation of test specimens

Take five specimens prepared in accordance with 6.1.2 using plungers No. 1 with cap, if an interferometer is used, or No. 3 and No. 2 (see the figure).

#### 6.3.2 Procedure

Place each specimen in the measuring instrument; do not subject specimens to a restraint greater than 0,02 N during the test. Make the initial measurement 5 min after the start of mixing and the final measurement after 24 h. During the test, maintain the specimen at a temperature of  $37 \pm 1$  °C. Record, to the nearest 0,01 %, the average change in length for five such specimens as the value for dimensional change during hardening (setting).

### 6.4 Determination of compressive strength

#### 6.4.1 Preparation of test specimens

Take ten specimens prepared in accordance with 6.1.2 using plungers Nos. 2 and 3 (see the figure).

#### 6.4.2 Procedure

Determine the compressive strength of five specimens  $60 \pm 2$  min after amalgamation and the other five specimens  $24 \text{ h} \pm 15 \text{ min}$  after amalgamation by means of a suitable testing machine the cross-head speed of which shall be 0,5 mm/min. Apply the force axially.

Record separately, as the 1 h and 24 h after amalgamation compressive strengths of the amalgam, the average of the compressive strengths of the five 1 h and the five 24 h specimens reported to the nearest 1,0 MPa. Calculate the coefficient of variation of each series. If this exceeds 15 %, carry out a further five tests of that series. Calculate the average for the 10 results.

### 6.5 Determination of mass

Weigh 25 tablets individually, to the nearest 1 mg. In the case of pre-dosed capsules, weigh both the alloy and the mercury from 25 capsules and calculate the average and coefficient of variation.

### 6.6 Determination of capsule loss in mass

Weigh five capsules before and after amalgamation after cooling to room temperature.

## 7 Packaging, marking and manufacturer's instructions

### 7.1 Packaging

The alloy shall be packaged so as to prevent spillage or contamination of the alloy or mercury (if in capsule form).

### 7.2 Marking

7.2.1 Each package of bulk alloy, tubes of pellets or pre-dosed capsules shall be marked with a serial number or a combination of letters and numbers, which refer to the manufacturer's records for that particular lot or batch.

7.2.2 The manufacturer shall mark on the container (7.2.1) a list of those elements present in the alloy in concentrations greater than 0,1 % (*m/m*). The manufacturer shall also present a description of the particle shape, for example lathe cut, spherical (atomized), irregular or a mixture of two or more shapes.

### 7.3 Manufacturer's instructions

Instructions shall accompany each container and shall include at least the following details:

- a) the ratio of alloy to mercury by mass;
- b) description of the machine for mixing the contents of the capsule (pestle, if required), together with the speed and time;
- c) if the alloy used to make the amalgam contains more than 0,01 % of zinc, the following precaution shall be printed in bold type:

**"THIS ALLOY CONTAINS ZINC, AND THE AMALGAM MADE THEREFROM WILL SHOW EXCESSIVE CORROSION AND EXPANSION IF MOISTURE IS INTRODUCED DURING MIXING OR COMPACTING."**

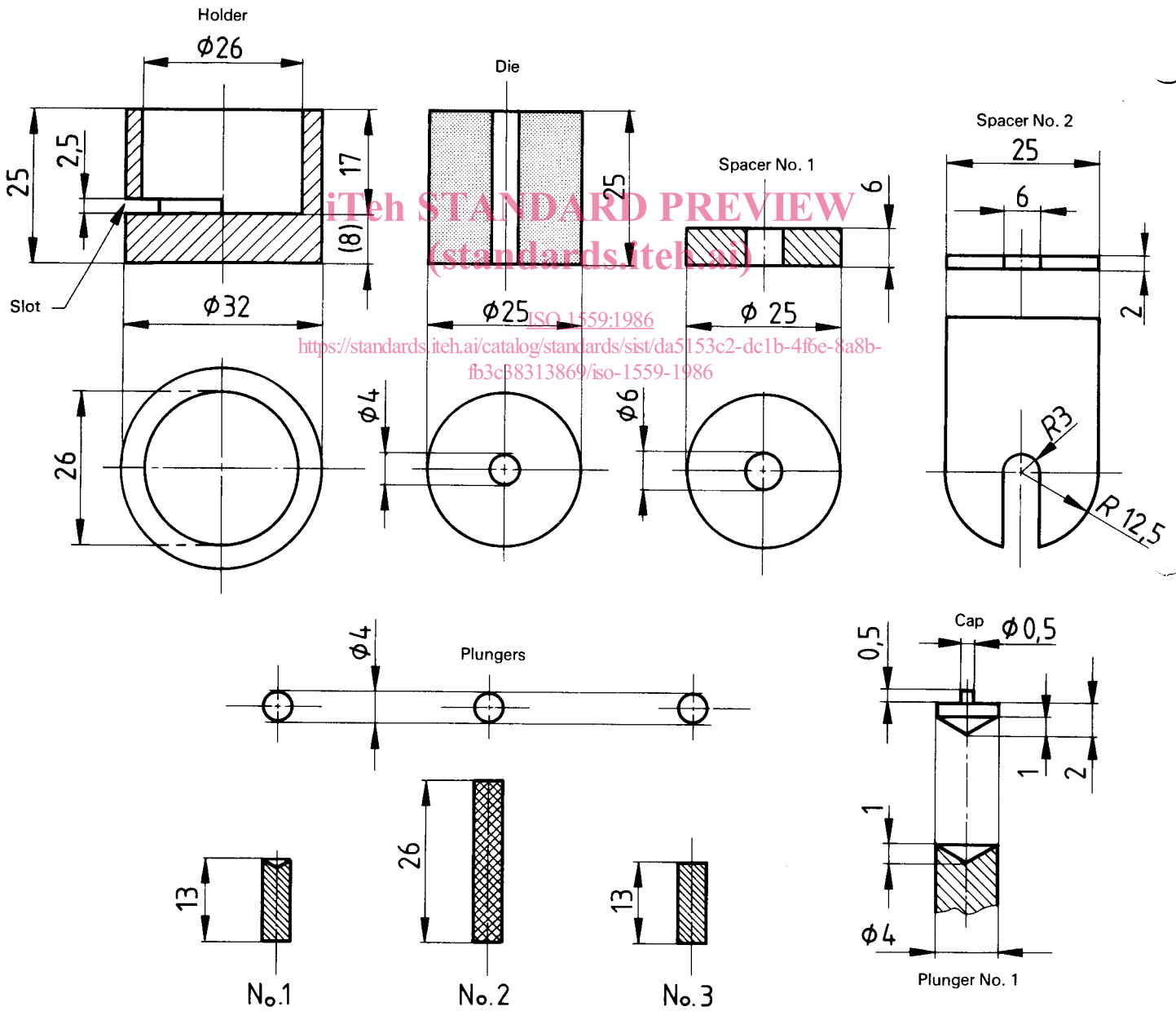
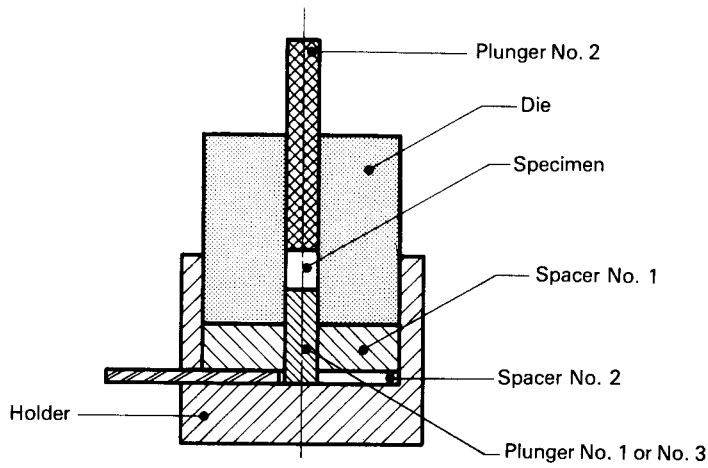

Figure – Mould for dental amalgam specimens

**iTeh STANDARD PREVIEW**  
**(standards.iteh.ai)**

[ISO 1559:1986](#)

<https://standards.iteh.ai/catalog/standards/sist/da5153c2-dc1b-4f6e-8a8b-fb3c38313869/iso-1559-1986>

**iTeh STANDARD PREVIEW**  
**(standards.iteh.ai)**

[ISO 1559:1986](#)

<https://standards.iteh.ai/catalog/standards/sist/da5153c2-dc1b-4f6e-8a8b-fb3c38313869/iso-1559-1986>