

**SLOVENSKI STANDARD
SIST EN ISO 2360:2017****01-november-2017****Nadomešča:****SIST EN ISO 2360:2004**

**Neprevodne prevleke na nemagnetnih električno prevodnih osnovnih kovinah -
Merjenje debeline prevleke - Metoda vrtničnih tokov, občutljiva za spremembe
amplitude (ISO 2360:2017)**Non-conductive coatings on non-magnetic electrically conductive base metals -
Measurement of coating thickness - Amplitude-sensitive eddy-current method (ISO
2360:2017)**iTeh STANDARD PREVIEW****(standards.iteh.ai)**Nichtleitende Überzüge auf nichtmagnetischen metallischen Grundwerkstoffen - Messen
der Schichtdicke - Wirbelstromverfahren (ISO 2360:2017)[SIST EN ISO 2360:2017](https://standards.iteh.ai/catalog/standards/sist/df71adce-1d35-42d4-9c80-41e98c544935/sist-en-iso-2360-2017)[https://standards.iteh.ai/catalog/standards/sist/df71adce-1d35-42d4-9c80-](https://standards.iteh.ai/catalog/standards/sist/df71adce-1d35-42d4-9c80-41e98c544935/sist-en-iso-2360-2017)Revêtements non conducteurs sur matériaux de base non magnétiques conducteurs de
l'électricité - Mesurage de l'épaisseur de revêtement - Méthode par courants de Foucault
sensible aux variations d'amplitude (ISO 2360:2017)**Ta slovenski standard je istoveten z: EN ISO 2360:2017****ICS:**

25.220.20 Površinska obdelava Surface treatment

SIST EN ISO 2360:2017**en**

iTeh STANDARD PREVIEW
(standards.iteh.ai)

[SIST EN ISO 2360:2017](https://standards.iteh.ai/catalog/standards/sist/df71adce-1d35-42d4-9c80-b4ae8e540925/sist-en-iso-2360-2017)

<https://standards.iteh.ai/catalog/standards/sist/df71adce-1d35-42d4-9c80-b4ae8e540925/sist-en-iso-2360-2017>

EUROPEAN STANDARD

EN ISO 2360

NORME EUROPÉENNE

EUROPÄISCHE NORM

August 2017

ICS 25.220.20

Supersedes EN ISO 2360:2003

English Version

Non-conductive coatings on non-magnetic electrically conductive base metals - Measurement of coating thickness - Amplitude-sensitive eddy-current method (ISO 2360:2017)

Revêtements non conducteurs sur matériaux de base
non magnétiques conducteurs de l'électricité -
Mesurage de l'épaisseur de revêtement - Méthode par
courants de Foucault sensible aux variations
d'amplitude (ISO 2360:2017)

Nichtleitende Überzüge auf nichtmagnetischen
metallischen Grundwerkstoffen - Messen der
Schichtdicke - Wirbelstromverfahren (ISO 2360:2017)

This European Standard was approved by CEN on 8 July 2017.

CEN members are bound to comply with the CEN/CENELEC Internal Regulations which stipulate the conditions for giving this European Standard the status of a national standard without any alteration. Up-to-date lists and bibliographical references concerning such national standards may be obtained on application to the CEN-CENELEC Management Centre or to any CEN member.

This European Standard exists in three official versions (English, French, German). A version in any other language made by translation under the responsibility of a CEN member into its own language and notified to the CEN-CENELEC Management Centre has the same status as the official versions.

CEN members are the national standards bodies of Austria, Belgium, Bulgaria, Croatia, Cyprus, Czech Republic, Denmark, Estonia, Finland, Former Yugoslav Republic of Macedonia, France, Germany, Greece, Hungary, Iceland, Ireland, Italy, Latvia, Lithuania, Luxembourg, Malta, Netherlands, Norway, Poland, Portugal, Romania, Serbia, Slovakia, Slovenia, Spain, Sweden, Switzerland, Turkey and United Kingdom.



EUROPEAN COMMITTEE FOR STANDARDIZATION
COMITÉ EUROPÉEN DE NORMALISATION
EUROPÄISCHES KOMITEE FÜR NORMUNG

CEN-CENELEC Management Centre: Avenue Marnix 17, B-1000 Brussels

Contents	Page
European foreword.....	3

iTeh STANDARD PREVIEW
(standards.iteh.ai)

[SIST EN ISO 2360:2017](https://standards.iteh.ai/catalog/standards/sist/df71adce-1d35-42d4-9c80-b4ae8e540925/sist-en-iso-2360-2017)
[https://standards.iteh.ai/catalog/standards/sist/df71adce-1d35-42d4-9c80-
b4ae8e540925/sist-en-iso-2360-2017](https://standards.iteh.ai/catalog/standards/sist/df71adce-1d35-42d4-9c80-b4ae8e540925/sist-en-iso-2360-2017)

European foreword

This document (EN ISO 2360:2017) has been prepared by Technical Committee ISO/TC 107 “Metallic and other inorganic coatings” in collaboration with Technical Committee CEN/TC 262 “Metallic and other inorganic coatings, including for corrosion protection and corrosion testing of metals and alloys” the secretariat of which is held by BSI.

This European Standard shall be given the status of a national standard, either by publication of an identical text or by endorsement, at the latest by February 2018, and conflicting national standards shall be withdrawn at the latest by February 2018.

Attention is drawn to the possibility that some of the elements of this document may be the subject of patent rights. CEN shall not be held responsible for identifying any or all such patent rights.

This document supersedes EN ISO 2360:2003.

According to the CEN-CENELEC Internal Regulations, the national standards organizations of the following countries are bound to implement this European Standard: Austria, Belgium, Bulgaria, Croatia, Cyprus, Czech Republic, Denmark, Estonia, Finland, Former Yugoslav Republic of Macedonia, France, Germany, Greece, Hungary, Iceland, Ireland, Italy, Latvia, Lithuania, Luxembourg, Malta, Netherlands, Norway, Poland, Portugal, Romania, Serbia, Slovakia, Slovenia, Spain, Sweden, Switzerland, Turkey and the United Kingdom.

PREVIEW

(standards.iteh.ai)

Endorsement notice

The text of ISO 2360:2017 has been approved by CEN as EN ISO 2360:2017 without any modification.

SIST EN ISO 2360:2017
<https://standards.iteh.ai/catalog/standards/sist/d171adce-1d55-42d4-9c80-b4ae8e540925/sist-en-iso-2360-2017>

iTeh STANDARD PREVIEW
(standards.iteh.ai)

[SIST EN ISO 2360:2017](https://standards.iteh.ai/catalog/standards/sist/df71adce-1d35-42d4-9c80-b4ae8e540925/sist-en-iso-2360-2017)

<https://standards.iteh.ai/catalog/standards/sist/df71adce-1d35-42d4-9c80-b4ae8e540925/sist-en-iso-2360-2017>

INTERNATIONAL
STANDARDISO
2360Fourth edition
2017-07

**Non-conductive coatings on non-
magnetic electrically conductive base
metals — Measurement of coating
thickness — Amplitude-sensitive
eddy-current method**

*Revêtements non conducteurs sur matériaux de base non
magnétiques conducteurs de l'électricité — Mesurage de l'épaisseur
de revêtement — Méthode par courants de Foucault sensible aux
variations d'amplitude*

[SIST EN ISO 2360:2017](https://standards.iteh.ai/catalog/standards/sist/df71adce-1d35-42d4-9c80-b4ae8e540925/sist-en-iso-2360-2017)

[https://standards.iteh.ai/catalog/standards/sist/df71adce-1d35-42d4-9c80-
b4ae8e540925/sist-en-iso-2360-2017](https://standards.iteh.ai/catalog/standards/sist/df71adce-1d35-42d4-9c80-b4ae8e540925/sist-en-iso-2360-2017)

Reference number
ISO 2360:2017(E)

© ISO 2017

iTeh STANDARD PREVIEW
(standards.iteh.ai)

SIST EN ISO 2360:2017

<https://standards.iteh.ai/catalog/standards/sist/df71adce-1d35-42d4-9c80-b4ae8e540925/sist-en-iso-2360-2017>



COPYRIGHT PROTECTED DOCUMENT

© ISO 2017, Published in Switzerland

All rights reserved. Unless otherwise specified, no part of this publication may be reproduced or utilized otherwise in any form or by any means, electronic or mechanical, including photocopying, or posting on the internet or an intranet, without prior written permission. Permission can be requested from either ISO at the address below or ISO's member body in the country of the requester.

ISO copyright office
Ch. de Blandonnet 8 • CP 401
CH-1214 Vernier, Geneva, Switzerland
Tel. +41 22 749 01 11
Fax +41 22 749 09 47
copyright@iso.org
www.iso.org

Contents

	Page
Foreword	iv
1 Scope	1
2 Normative references	1
3 Terms and definitions	1
4 Principle of measurement	2
5 Factors affecting measurement uncertainty	3
5.1 Basic influence of the coating thickness	3
5.2 Electrical properties of the base metal	3
5.3 Geometry: Base metal thickness	4
5.4 Geometry: Edge effects	4
5.5 Geometry: Surface curvature	4
5.6 Surface roughness	4
5.7 Cleanliness: Lift-off effect	5
5.8 Probe pressure	5
5.9 Probe tilt	5
5.10 Temperature effects	5
5.11 Intermediate coatings	6
5.12 External electromagnetic fields	6
6 Calibration and adjustment of the instrument	6
6.1 General	6
6.2 Thickness reference standards	6
6.3 Methods of adjustment	7
7 Measurement procedure and evaluation	8
7.1 General	8
7.2 Number of measurements and evaluation	8
8 Uncertainty of the results	8
8.1 General remarks	8
8.2 Uncertainty of the calibration of the instrument	9
8.3 Stochastic errors	10
8.4 Uncertainties caused by factors summarized in Clause 5	10
8.5 Combined uncertainty, expanded uncertainty and final result	11
9 Precision	11
9.1 General	11
9.2 Repeatability (r)	11
9.3 Reproducibility limit (R)	12
10 Test report	12
Annex A (informative) Eddy-current generation in a metallic conductor	14
Annex B (informative) Basics of the determination of the uncertainty of a measurement of the used measurement method corresponding to ISO/IEC Guide 98-3	18
Annex C (informative) Basic performance requirements for coating thickness gauges which are based on the amplitude-sensitive eddy-current method described in this document	20
Annex D (informative) Examples for the experimental estimation of factors affecting the measurement accuracy	22
Annex E (informative) Table of the student factor	27
Annex F (informative) Example of uncertainty estimation (see Clause 8)	28
Annex G (informative) Details on precision	30
Bibliography	34

ISO 2360:2017(E)

Foreword

ISO (the International Organization for Standardization) is a worldwide federation of national standards bodies (ISO member bodies). The work of preparing International Standards is normally carried out through ISO technical committees. Each member body interested in a subject for which a technical committee has been established has the right to be represented on that committee. International organizations, governmental and non-governmental, in liaison with ISO, also take part in the work. ISO collaborates closely with the International Electrotechnical Commission (IEC) on all matters of electrotechnical standardization.

The procedures used to develop this document and those intended for its further maintenance are described in the ISO/IEC Directives, Part 1. In particular the different approval criteria needed for the different types of ISO documents should be noted. This document was drafted in accordance with the editorial rules of the ISO/IEC Directives, Part 2 (see www.iso.org/directives).

Attention is drawn to the possibility that some of the elements of this document may be the subject of patent rights. ISO shall not be held responsible for identifying any or all such patent rights. Details of any patent rights identified during the development of the document will be in the Introduction and/or on the ISO list of patent declarations received (see www.iso.org/patents).

Any trade name used in this document is information given for the convenience of users and does not constitute an endorsement.

For an explanation on the voluntary nature of standards, the meaning of ISO specific terms and expressions related to conformity assessment, as well as information about ISO's adherence to the World Trade Organization (WTO) principles in the Technical Barriers to Trade (TBT) see the following URL: www.iso.org/iso/foreword.html. (standards.iteh.ai)

This document was prepared by Technical Committee ISO/TC 107, *Metallic and other inorganic coatings*.

This fourth edition cancels and replaces the third edition (ISO 2360:2003), which has been technically revised.

Non-conductive coatings on non-magnetic electrically conductive base metals — Measurement of coating thickness — Amplitude-sensitive eddy-current method

1 Scope

This document specifies a method for non-destructive measurements of the thickness of non-conductive coatings on non-magnetic electrically conductive base metals, using amplitude-sensitive eddy-current instruments.

In this document, the term “coating” is used for materials such as, for example, paints and varnishes, electroplated coatings, enamel coatings, plastic coatings, claddings and powder coatings. This method is particularly applicable to measurements of the thickness of most oxide coatings produced by anodizing, but is not applicable to all conversion coatings, some of which are too thin to be measured by this method (see [Clause 6](#)).

This method can also be used to measure non-magnetic metallic coatings on non-conductive base materials. However, the phase-sensitive eddy-current method specified in ISO 21968 is particularly usable to this application and can provide thickness results with a higher accuracy (see [Annex A](#)).

This method is not applicable to measure non-magnetic metallic coatings on conductive base metals. The phase-sensitive eddy-current method specified in ISO 21968 is particularly useful for this application. However, in the special case of very thin coatings with a very small conductivity, the amplitude-sensitive eddy-current method can also be used for this application (see [Annex A](#)).

Although the method can be used for measurements of the thickness of coatings on magnetic base metals, its use for this application is not recommended. In such cases, the magnetic method specified in ISO 2178 can be used. Only in case of very thick coatings above approximately 1 mm, the amplitude-sensitive eddy-current method can also be used for this application (see [Annex A](#)).

2 Normative references

The following documents are referred to in the text in such a way that some or all of their content constitutes requirements of this document. For dated references, only the edition cited applies. For undated references, the latest edition of the referenced document (including any amendments) applies.

ISO 2064, *Metallic and other inorganic coatings — Definitions and conventions concerning the measurement of thickness*

ISO 4618, *Paints and varnishes — Terms and definitions*

ISO/IEC Guide 98-3, *Uncertainty of measurement — Part 3: Guide to the expression of uncertainty in measurement (GUM:1995)*

3 Terms and definitions

For the purposes of this document, the terms and definitions given in ISO 2064 and ISO 4618 and the following apply.

ISO and IEC maintain terminological databases for use in standardization at the following addresses:

- IEC Electropedia: available at <http://www.electropedia.org/>
- ISO Online browsing platform: available at <http://www.iso.org/obp>

ISO 2360:2017(E)

3.1 adjustment of a measuring system

set of operations carried out on a measuring system so that it provides prescribed indications corresponding to given values of a quantity to be measured

Note 1 to entry: Adjustment of a measuring system can include zero adjustment, offset adjustment, and span adjustment (sometimes called gain adjustment).

Note 2 to entry: Adjustment of a measuring system should not be confused with calibration, which is a prerequisite for adjustment.

Note 3 to entry: After an adjustment of a measuring system, the measuring system must usually be recalibrated.

Note 4 to entry: Colloquially, the term “calibration” is frequently, but falsely, used instead of the term “adjustment”. In the same way, the terms “verification” and “checking” are often used instead of the correct term “calibration”.

[SOURCE: ISO/IEC Guide 99:2007, 3.11 (also known as “VIM”)]

3.2 calibration

operation that, under specified conditions, in a first step, establishes a relation between the quantity values with measurement uncertainties provided by measurement standards and corresponding indications with associated measurement uncertainties and, in a second step, uses this information to establish a relation for obtaining a measurement result from an indication

Note 1 to entry: A calibration may be expressed by a statement, calibration function, calibration diagram, calibration curve, or calibration table. In some cases, it may consist of an additive or multiplicative correction of the indication with associated measurement uncertainty.

Note 2 to entry: Calibration should not be confused with adjustment of a measuring system, often mistakenly called “self-calibration”, nor with verification of calibration.

Note 3 to entry: Often, the first step alone in the above definition is perceived as being calibration.

[SOURCE: ISO/IEC Guide 99:2007, 2.39 (also known as “VIM”)]

4 Principle of measurement

Eddy-current instruments work on the principle that a high frequency electromagnetic field generated by the probe system of the instrument will produce eddy-currents in the base metal beneath the coating on which the probe is placed (see [Figure 1](#)). These induced currents cause a change of the electromagnetic field surrounding the probe coil and therefore result in a change of the amplitude of the probe coil impedance. The induced eddy-current density is a function of the distance between the generating coil and the base metal surface. Consequently, this impedance change can be used as a measure of the thickness of the coating on the conductor by means of a calibration with reference standards (see also [Annex A](#)).

In order to measure a change of the coil impedance amplitude, the test coil is usually part of an oscillator [circuit](#) with a resonant frequency determined by the coil inductance and resistance. A change of the coil impedance amplitude results in a shift of the resonant frequency. Consequently, the measured resonant frequency is a measure of the coating thickness. The values are either pre-processed by digital means or are directly displayed on a usefully scaled gauge.

The probe and measuring system/display may be integrated into a single instrument.

NOTE 1 [Annex C](#) describes the basic performance requirements of the equipment.

NOTE 2 Factors affecting measurement accuracy are discussed in [Clause 5](#).

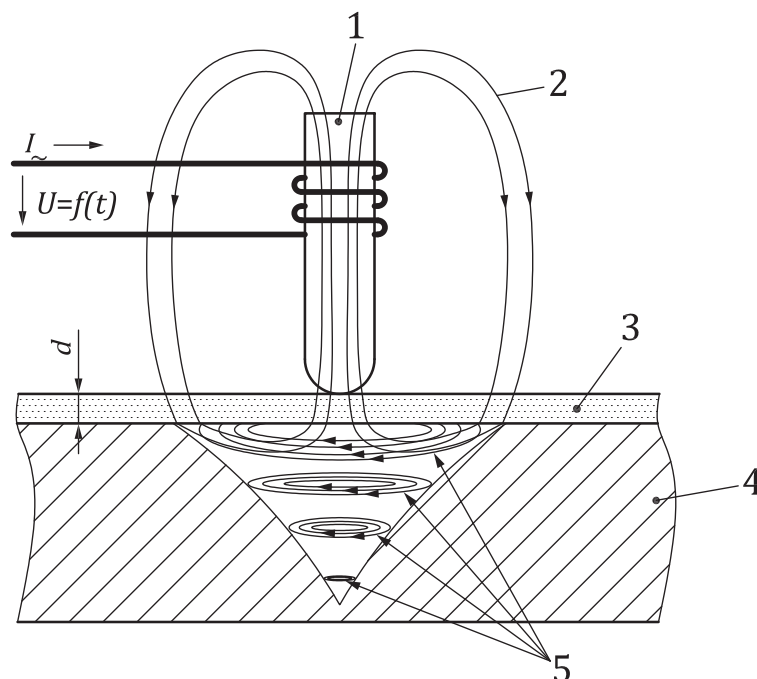
**Key**

- | | | | |
|---|--------------------------------------|----------|----------------------|
| 1 | ferrite core of the probe | 5 | induced eddy-current |
| 2 | high frequency electromagnetic field | I_e | exciting current |
| 3 | non-conductive coating | t | coating thickness |
| 4 | base metal | $U=f(t)$ | measurement signal |

SIST EN ISO 2360:2017
Figure 1 — Amplitude-sensitive eddy-current method
<https://standards.iteh.ai/catalog/standards/sist/d171adcc-1d35-42d4-9c80-b4ae8e540925/sist-en-iso-2360-2017>

5 Factors affecting measurement uncertainty

5.1 Basic influence of the coating thickness

The sensitivity of a probe, i.e. the measurement effect, decreases with increasing thickness within the measurement range of the probe. In the lower measurement range, this measurement uncertainty (in absolute terms) is constant, independent of the coating thickness. The absolute value of this uncertainty depends on the properties of the probe system and the sample materials, e.g. the homogeneity of the base metal conductivity, the base metal roughness and the sample surface roughness. In the upper measurement range, the uncertainty becomes approximately a constant fraction of the coating thickness.

5.2 Electrical properties of the base metal

The conductivity of the base metal determines the induced eddy-current density for a given probe system and frequency. Consequently, the base metal conductivity causes the measurement effect for this method. The relationship between coating thickness and the measured value depends strongly on the conductivity of the base metal. Consequently, calibration procedures and measurements shall be made on the same material. Different materials with different conductivities as well as local fluctuations of the conductivity or variations between different samples can cause (more or less) errors in the thickness reading.

NOTE There are instruments and probes available that are capable of automatically compensating the base metal conductivity influence thus avoiding the resulting thickness error.