**Prevailing torque type all-metal hexagon
nuts with flange, style 2 — Product
grades A and B**

*Écrous hexagonaux à embase, autofreinés, tout métal, style 2 —
Grades A et B*

iTeh STANDARD PREVIEW
(standards.iteh.ai)

[ISO 7044:2012](https://standards.iteh.ai/catalog/standards/sist/82b8a60b-0206-437d-bdbc-c0a9e6ee2d0c/iso-7044-2012)

[https://standards.iteh.ai/catalog/standards/sist/82b8a60b-0206-437d-bdbc-
c0a9e6ee2d0c/iso-7044-2012](https://standards.iteh.ai/catalog/standards/sist/82b8a60b-0206-437d-bdbc-c0a9e6ee2d0c/iso-7044-2012)



iTeh STANDARD PREVIEW (standards.iteh.ai)

ISO 7044:2012

<https://standards.iteh.ai/catalog/standards/sist/82b8a60b-0206-437d-bdbc-c0a9e6ee2d0c/iso-7044-2012>



COPYRIGHT PROTECTED DOCUMENT

© ISO 2012

All rights reserved. Unless otherwise specified, no part of this publication may be reproduced or utilized in any form or by any means, electronic or mechanical, including photocopying and microfilm, without permission in writing from either ISO at the address below or ISO's member body in the country of the requester.

ISO copyright office
Case postale 56 • CH-1211 Geneva 20
Tel. + 41 22 749 01 11
Fax + 41 22 749 09 47
E-mail copyright@iso.org
Web www.iso.org

Published in Switzerland

Contents		Page
Foreword		iv
1	Scope	1
2	Normative references	1
3	Dimensions	1
4	Requirements and reference International Standards	4
5	Designation	4
Annex A (informative) Gauging of hexagon nuts with flange		5
Bibliography		7

iTeh STANDARD PREVIEW
(standards.iteh.ai)

[ISO 7044:2012](https://standards.iteh.ai/catalog/standards/sist/82b8a60b-0206-437d-bdbc-c0a9e6ee2d0c/iso-7044-2012)

<https://standards.iteh.ai/catalog/standards/sist/82b8a60b-0206-437d-bdbc-c0a9e6ee2d0c/iso-7044-2012>

Foreword

ISO (the International Organization for Standardization) is a worldwide federation of national standards bodies (ISO member bodies). The work of preparing International Standards is normally carried out through ISO technical committees. Each member body interested in a subject for which a technical committee has been established has the right to be represented on that committee. International organizations, governmental and non-governmental, in liaison with ISO, also take part in the work. ISO collaborates closely with the International Electrotechnical Commission (IEC) on all matters of electrotechnical standardization.

International Standards are drafted in accordance with the rules given in the ISO/IEC Directives, Part 2.

The main task of technical committees is to prepare International Standards. Draft International Standards adopted by the technical committees are circulated to the member bodies for voting. Publication as an International Standard requires approval by at least 75 % of the member bodies casting a vote.

Attention is drawn to the possibility that some of the elements of this document may be the subject of patent rights. ISO shall not be held responsible for identifying any or all such patent rights.

ISO 7044 was prepared by Technical Committee ISO/TC 2, *Fasteners*, Subcommittee SC 12, *Fasteners with metric internal thread*.

This third edition cancels and replaces the second edition (ISO 7044:1997), of which it constitutes a minor revision.

iTeh STANDARD PREVIEW (standards.iteh.ai)

[ISO 7044:2012](https://standards.iteh.ai/catalog/standards/sist/82b8a60b-0206-437d-bdbc-c0a9e6ee2d0c/iso-7044-2012)

<https://standards.iteh.ai/catalog/standards/sist/82b8a60b-0206-437d-bdbc-c0a9e6ee2d0c/iso-7044-2012>

Prevailing torque type all-metal hexagon nuts with flange, style 2 — Product grades A and B

1 Scope

This International Standard specifies the characteristics of prevailing torque type all-metal hexagon nuts with flange (style 2) and threads M5 to M20 inclusive, in product grade A for threads up to and including M16 and product grade B for threads above M16, and with property classes 8, 9, 10 and 12.

NOTE The dimensions of the nuts correspond to those given in ISO 4161 plus prevailing torque feature.

If other specifications are required, they can be selected from existing International Standards, for example ISO 261, ISO 724, ISO 898-2, ISO 965-2, ISO 2320 and ISO 4759-1.

2 Normative references

The following referenced documents are indispensable for the application of this document. For dated references, only the edition cited applies. For undated references, the latest edition of the referenced document (including any amendments) applies.

ISO 225, *Fasteners — Bolts, screws, studs and nuts — Symbols and descriptions of dimensions*

ISO 261, *ISO general purpose metric screw threads — General plan*

ISO 724, *ISO general-purpose metric screw threads — Basic dimensions*

ISO 898-2, *Mechanical properties of fasteners made of carbon steel and alloy steel — Part 2: Nuts with specified property classes — Coarse thread and fine pitch thread*

ISO 965-2, *ISO general purpose metric screw threads — Tolerances — Part 2: Limits of sizes for general purpose external and internal screw threads — Medium quality*

ISO 2320, *Prevailing torque type steel nuts — Mechanical and performance properties*

ISO 3269, *Fasteners — Acceptance inspection*

ISO 4042, *Fasteners — Electroplated coatings*

ISO 4759-1, *Tolerances for fasteners — Part 1: Bolts, screws, studs and nuts — Product grades A, B and C*

ISO 6157-2, *Fasteners — Surface discontinuities — Part 2: Nuts*

ISO 8992, *Fasteners — General requirements for bolts, screws, studs and nuts*

ISO 10683, *Fasteners — Non-electrolytically applied zinc flake coatings*

3 Dimensions

See Figure 1 and Table 1.

Symbols and descriptions of dimensions are specified in ISO 225.

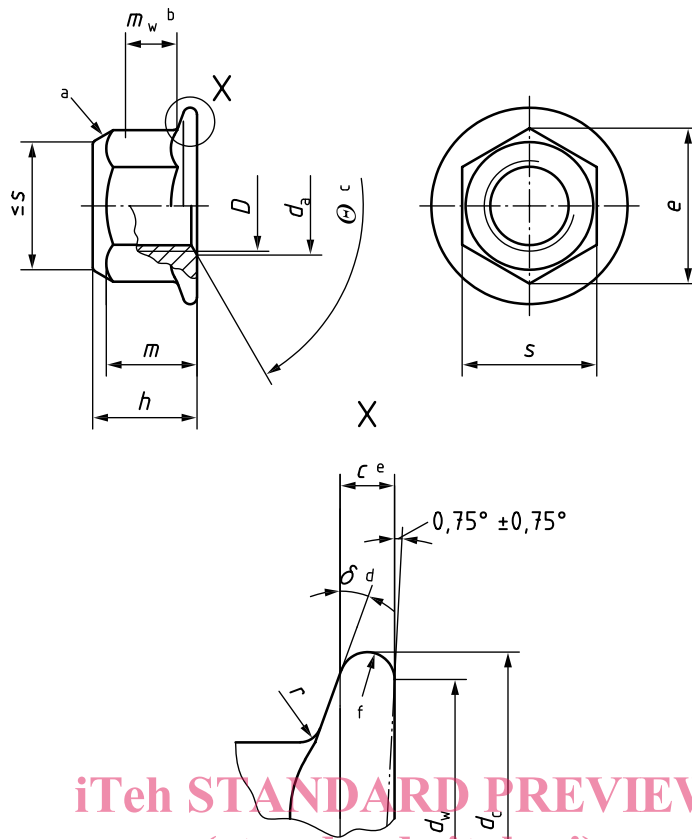

iTeh STANDARD PREVIEW
(standards.iteh.ai)

- a Prevailing torque element, shape is at the discretion of the manufacturer.
- b m_w is the wrenching height; see note to Table 1. [ISO 7044:2012](https://standards.iteh.ai/catalog/standards/sist/82b8a60b-0206-437d-bdbc-c0a9e6ee2d0c/iso-7044-2012)
- c $\theta = 90^\circ$ to 120° . <https://standards.iteh.ai/catalog/standards/sist/82b8a60b-0206-437d-bdbc-c0a9e6ee2d0c/iso-7044-2012>
- d $\delta = 15^\circ$ to 25° .
- e c is measured at $d_{w,min}$.
- f Contour of the edge is at the discretion of the manufacturer.

Figure 1

Table 1 — Dimensions

Dimensions in millimetres

Thread <i>D</i>		M5	M6	M8	M10	M12	(M14) ^a	M16	M20
<i>p</i> ^b		0,8	1	1,25	1,5	1,75	2	2	2,5
<i>c</i>	min.	1,0	1,1	1,2	1,5	1,8	2,1	2,4	3,0
	max.	5,75	6,75	8,75	10,80	13,00	15,10	17,30	21,60
<i>d_a</i>	min.	5,00	6,00	8,00	10,00	12,00	14,00	16,00	20,00
	max.	11,8	14,2	17,9	21,8	26,0	29,9	34,5	42,8
<i>d_c</i>	min.	9,8	12,2	15,8	19,6	23,8	27,6	31,9	39,9
<i>e</i>	min.	8,79	11,05	14,38	16,64	20,03	23,36	26,75	32,95
<i>h</i>	max.	6,20	7,30	9,40	11,40	13,80	15,90	18,30	22,40
	min.	5,70	6,80	8,74	10,34	12,57	14,80	17,20	20,30
<i>m^c</i>	min.	4,70	5,70	7,64	9,64	11,57	13,30	15,30	18,70
<i>m_w</i>	min.	2,5	3,1	4,6	5,6	6,8	7,7	8,9	10,7
<i>s</i>	max.	8,00	10,00	13,00	15,00	18,00	21,00	24,00	30,00
	min.	7,78	9,78	12,73	14,73	17,73	20,67	23,67	29,16
<i>r^d</i>	max.	0,3	0,4	0,5	0,6	0,7	0,9	1,0	1,2

NOTE If the product passes the gauging given in Annex A, the requirements for dimensions *e*, *c* and *m_w* are satisfied.

^a The size in parentheses should be avoided if possible.

^b *P* is the pitch of the thread.

^c *m* is the minimum thread height.

^d Radius, *r*, applies both at the corners and the flats of the hexagon.

ISO 7044:2012

<https://standards.iteh.ai/catalog/standards/sist/82b8a60b-0206-437d-bdbc-c0a9e6ee2d0c/iso-7044-2012>

4 Requirements and reference International Standards

See Table 2.

Table 2 — Requirements and reference International Standards

Material		Steel
General requirements	International Standard	ISO 8992
Thread	Tolerance class	6H
	International Standards	ISO 261, ISO 724, ISO 965-2
Mechanical and performance properties	Property class	8, 9, 10, 12
	International Standard	ISO 898-2, ISO 2320
Tolerance	Product grade	For $D \leq 16$ mm: A For $D > 16$ mm: B
	International Standard	ISO 4759-1
Finish — Coating		As processed Requirements for electroplating are specified in ISO 4042. Requirements for non-electrolytically applied zinc flake coatings are specified in ISO 10683. Additional requirements or other finishes or coatings shall be agreed between the supplier and the purchaser.
Surface integrity		Limits for surface discontinuities are specified in ISO 6157-2.
Acceptability		For acceptance procedure, see ISO 3269.

5 Designation

EXAMPLE A prevailing torque type all-metal hexagon nut with flange, thread M12 and of property class 8 is designated as follows:

Prevailing torque type hexagon nut with flange ISO 7044 - M12 - 8

Annex A (informative)

Gauging of hexagon nuts with flange

A.1 Recommended method for gauging of hexagon

See Figure A.1 and Table A.1.

The nut shall be gauged using two plain ring gauges, A and B, to demonstrate the coincidental acceptability of hexagon height, wrenching height, corner fill and width across corners. Gauge A shall be placed over the hexagon and shall be seated on the flange. Gauge B shall be placed on the top of the nut normal to the nut axis. The two gauges shall not be in contact.

A.2 Recommended method for gauging flange thickness

See Figure A.1 and Table A.1.

Gauge C is a flat feeler or ring gauge. It is used to prove that the flange thickness at the junction of the gauge with the hexagon portion is equal to or greater than specified values. The acceptance criterion is that gauge C fits under gauge A without contact when the nut is seated on a flat plate.

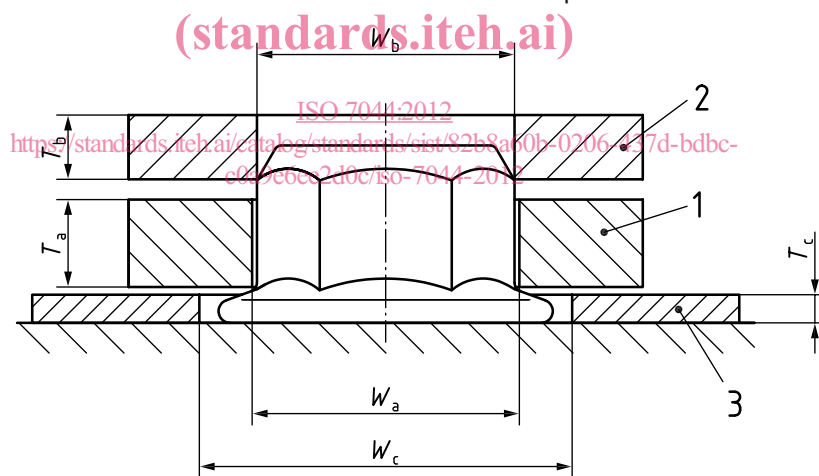

Key

- 1 gauge A
- 2 gauge B
- 3 gauge C

NOTE $W_{a,min} = e_{theoretical}$
 $W_{b,max} = e_{min} - 0,01 \text{ mm}$
 $T_{a,max} = m_{w,min}$

Figure A.1