**Hexagon regular nuts (style 1) —
Product grade C**

Écrous hexagonaux normaux (style 1) — Grade C

**iTeh STANDARD PREVIEW
(standards.iteh.ai)**

[ISO 4034:2012](https://standards.iteh.ai/catalog/standards/sist/9aa54815-b262-4608-9605-b29f51d409ce/iso-4034-2012)

[https://standards.iteh.ai/catalog/standards/sist/9aa54815-b262-4608-9605-
b29f51d409ce/iso-4034-2012](https://standards.iteh.ai/catalog/standards/sist/9aa54815-b262-4608-9605-b29f51d409ce/iso-4034-2012)



iTeh STANDARD PREVIEW
(standards.iteh.ai)

ISO 4034:2012
<https://standards.iteh.ai/catalog/standards/sist/9aa54815-b262-4608-9605-b29f51d409ce/iso-4034-2012>



COPYRIGHT PROTECTED DOCUMENT

© ISO 2012

All rights reserved. Unless otherwise specified, no part of this publication may be reproduced or utilized in any form or by any means, electronic or mechanical, including photocopying and microfilm, without permission in writing from either ISO at the address below or ISO's member body in the country of the requester.

ISO copyright office
Case postale 56 • CH-1211 Geneva 20
Tel. + 41 22 749 01 11
Fax + 41 22 749 09 47
E-mail copyright@iso.org
Web www.iso.org

Published in Switzerland

Contents		Page
Foreword		iv
Introduction		v
1	Scope	1
2	Normative references	1
3	Dimensions	1
4	Requirements and reference International Standards	3
5	Designation	3
Bibliography		4

iTeh STANDARD PREVIEW
(standards.iteh.ai)

[ISO 4034:2012](https://standards.iteh.ai/catalog/standards/sist/9aa54815-b262-4608-9605-b29f51d409ce/iso-4034-2012)

<https://standards.iteh.ai/catalog/standards/sist/9aa54815-b262-4608-9605-b29f51d409ce/iso-4034-2012>

Foreword

ISO (the International Organization for Standardization) is a worldwide federation of national standards bodies (ISO member bodies). The work of preparing International Standards is normally carried out through ISO technical committees. Each member body interested in a subject for which a technical committee has been established has the right to be represented on that committee. International organizations, governmental and non-governmental, in liaison with ISO, also take part in the work. ISO collaborates closely with the International Electrotechnical Commission (IEC) on all matters of electrotechnical standardization.

International Standards are drafted in accordance with the rules given in the ISO/IEC Directives, Part 2.

The main task of technical committees is to prepare International Standards. Draft International Standards adopted by the technical committees are circulated to the member bodies for voting. Publication as an International Standard requires approval by at least 75 % of the member bodies casting a vote.

Attention is drawn to the possibility that some of the elements of this document may be the subject of patent rights. ISO shall not be held responsible for identifying any or all such patent rights.

ISO 4034 was prepared by Technical Committee ISO/TC 2, *Fasteners*, Subcommittee SC 12, *Fasteners with metric internal thread*.

This fourth edition cancels and replaces the third edition (ISO 4034:1999), of which it constitutes a minor revision.

iTeh STANDARD PREVIEW (standards.iteh.ai)

[ISO 4034:2012](https://standards.iteh.ai/catalog/standards/sist/9aa54815-b262-4608-9605-b29f51d409ce/iso-4034-2012)

<https://standards.iteh.ai/catalog/standards/sist/9aa54815-b262-4608-9605-b29f51d409ce/iso-4034-2012>

Introduction

This International Standard belongs to a complete group of product standards developed by ISO on external hexagon drive fasteners. It comprises the following:

- a) hexagon head bolts (ISO 4014, ISO 4015, ISO 4016 and ISO 8765);
- b) hexagon head screws (ISO 4017, ISO 4018 and ISO 8676);
- c) hexagon nuts (ISO 4032, ISO 4033, ISO 4034, ISO 4035, ISO 4036, ISO 7040, ISO 7041, ISO 7042, ISO 7719, ISO 7720, ISO 8673, ISO 8674, ISO 8675, ISO 10511, ISO 10512 and ISO 10513);
- d) hexagon bolts with flange (ISO 4162, ISO 15071 and ISO 15072);
- e) hexagon nuts with flange (ISO 4161, ISO 7043, ISO 7044, ISO 10663, ISO 12125, ISO 12126 and ISO 21670).

iTeh STANDARD PREVIEW (standards.iteh.ai)

[ISO 4034:2012](https://standards.iteh.ai/catalog/standards/sist/9aa54815-b262-4608-9605-b29f51d409ce/iso-4034-2012)

<https://standards.iteh.ai/catalog/standards/sist/9aa54815-b262-4608-9605-b29f51d409ce/iso-4034-2012>

iTeh STANDARD PREVIEW
(standards.iteh.ai)

ISO 4034:2012

<https://standards.iteh.ai/catalog/standards/sist/9aa54815-b262-4608-9605-b29f51d409ce/iso-4034-2012>

Hexagon regular nuts (style 1) — Product grade C

1 Scope

This International Standard specifies the characteristics of hexagon regular nuts (style 1) with threads from M5 up to and including M64 and product grade C.

If, in special cases, specifications other than those listed in this International Standard are required, they can be selected from existing International Standards, for example ISO 724, ISO 898-2, ISO 965-1 and ISO 4759-1.

2 Normative references

The following documents, in whole or in part, are normatively referenced in this document and are indispensable to its application. For dated references, only the edition cited applies. For undated references, the latest edition of the referenced document (including any amendments) applies.

ISO 225, *Fasteners — Bolts, screws, studs and nuts — Symbols and descriptions of dimensions*

ISO 724, *ISO general-purpose metric screw threads — Basic dimensions*

ISO 898-2, *Mechanical properties of fasteners made of carbon steel and alloy steel — Part 2: Nuts with specified property classes — Coarse thread and fine pitch thread*

ISO 965-1, *ISO general-purpose metric screw threads — Tolerances — Part 1: Principles and basic data*

ISO 3269, *Fasteners — Acceptance inspection*

ISO 4042, *Fasteners — Electroplated coatings*

ISO 4759-1, *Tolerances for fasteners — Part 1: Bolts, screws, studs and nuts — Product grades A, B and C*

ISO 8992, *Fasteners — General requirements for bolts, screws, studs and nuts*

ISO 10683, *Fasteners — Non-electrolytically applied zinc flake coatings*

ISO 10684, *Fasteners — Hot dip galvanized coatings*

3 Dimensions

See Figure 1 and Tables 1 and 2.

Symbols and descriptions of dimensions are specified in ISO 225.

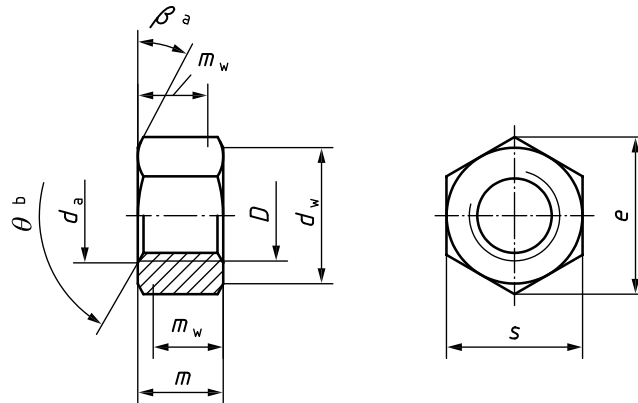

- a $\beta = 15^\circ$ to 30° .
- b $\theta = 90^\circ$ to 120° .

Figure 1

Table 1 — Preferred threads

Dimensions in millimetres

Thread <i>D</i>		M5	M6	M8	M10	M12	M16	M20
<i>p</i> ^a		0,8	1	1,25	1,5	1,75	2	2,5
<i>d_w</i>	min.	6,70	8,70	11,50	14,50	16,50	22,00	27,70
<i>e</i>	min.	8,63	10,89	14,20	17,59	19,85	26,17	32,95
<i>m</i>	max.	5,60	6,40	7,90	9,50	12,20	15,90	19,00
	min.	4,40	4,90	6,40	8,00	10,40	14,10	16,90
<i>m_w</i>	min.	3,50	3,70	5,10	6,40	8,30	11,30	13,50
<i>s</i>	nom. = max.	8,00	10,00	13,00	16,00	18,00	24,00	30,00
	min.	7,64	9,64	12,57	15,57	17,57	23,16	29,16
Thread		M24	M30	M36	M42	M48	M56	M64
<i>p</i> ^a		3	3,5	4	4,5	5	5,5	6
<i>d_w</i>	min.	33,30	42,80	51,10	60,00	69,50	78,70	88,20
<i>e</i>	min.	39,55	50,85	60,79	71,30	82,60	93,56	104,86
<i>m</i>	max.	22,30	26,40	31,90	34,90	38,90	45,90	52,40
	min.	20,20	24,30	29,40	32,40	36,40	43,40	49,40
<i>m_w</i>	min.	16,20	19,40	23,20	25,90	29,10	34,70	39,50
<i>s</i>	nom. = max.	36,00	46,00	55,00	65,00	75,00	85,00	95,00
	min.	35,00	45,00	53,80	63,10	73,10	82,80	92,80

^a *P* is the pitch of the thread.

Table 2 — Non-preferred threads

Dimensions in millimetres

Thread <i>D</i>		M14	M18	M22	M27	M33	M39	M45	M52	M60
p^a		2	2,5	2,5	3	3,5	4	4,5	5	5,5
d_w	min.	19,20	24,90	31,40	38,00	46,60	55,90	64,70	74,20	83,40
e	min.	22,78	29,56	37,29	45,20	55,37	66,44	76,95	88,25	99,21
m	max.	13,90	16,90	20,20	24,70	29,50	34,30	36,90	42,90	48,90
	min.	12,10	15,10	18,10	22,60	27,40	31,80	34,40	40,40	46,40
m_w	min.	9,70	12,10	14,50	18,10	21,90	25,40	27,50	32,30	37,10
s	nom. = max.	21,00	27,00	34,00	41,00	50,00	60,00	70,00	80,00	90,00
	min.	20,16	26,16	33,00	40,00	49,00	58,80	68,10	78,10	87,80
^a	P is the pitch of the thread.									

4 Requirements and reference International Standards

See Table 3.

Table 3 — Requirements and reference International Standards

Material	Steel
General requirements	International Standard ISO 8992
Thread	Tolerance class 7H
	International Standards ISO 724, ISO 965-1
Mechanical properties	Property class M5 < D ≤ M39: 5 D > M39: as agreed
	International Standard D ≤ M39: ISO 898-2 D > M39: as agreed (specified in ISO 898-2:2012, Annex A)
Tolerance	Product grade C
	International Standard ISO 4759-1
Finish — Coating	As processed Requirements for electroplating are specified in ISO 4042. Requirements for non-electrolytically applied zinc flake coatings are specified in ISO 10683. Requirements for hot dip galvanized coatings are specified in ISO 10684. Additional requirements or other finishes or coatings shall be agreed between the supplier and the purchaser.
Acceptability	Acceptance inspection is specified in ISO 3269.

5 Designation

EXAMPLE A hexagon regular nut (style 1) with thread M12 and property class 5 is designated as follows:

Hexagon regular nut ISO 4034 - M12 - 5