



# Standard Test Methods for Sampling and Testing Untreated Paper Used for Electrical Insulation<sup>1</sup>

This standard is issued under the fixed designation D 202; the number immediately following the designation indicates the year of original adoption or, in the case of revision, the year of last revision. A number in parentheses indicates the year of last reapproval. A superscript epsilon ( $\epsilon$ ) indicates an editorial change since the last revision or reapproval.

*This standard has been approved for use by agencies of the Department of Defense.*

<sup>ε1</sup>Note—Editorial changes made to footnotes 13-15, and Section 1 September 2002.

## 1. Scope Scope\*

1.1 These test methods cover procedures for sampling and testing untreated paper to be used as an electrical insulator or as a constituent of a composite material used for electrical insulating purposes.

1.1.1 Untreated papers are thin, fibrous sheets normally laid down from a water suspension of pulped fibers (usually cellulose), which may contain various amounts of nonfibrous ingredients, and which are calendared, if required, to obtain desired thickness and density. Nevertheless, these test methods are applicable, generally although not invariably, to papers formed by other means, to papers modified (during or after formation) by additions, and to papers given subsequent mechanical treatments such as creping.

1.1.2 As an electrical insulating and dielectric material, paper is considered “untreated” until it is subjected to a manufacturing process such as drying, impregnation, or varnish treatment.

1.1.3 The test methods given herein were developed specifically for papers having a thickness of 0.75 mm (0.030 in.) or less. A number of these test methods are also suitable for use on other materials such as pulps or boards. Refer to Test Methods D 3376 or Methods D 3394 to determine which tests are applicable to pulps or electrical insulating boards. In the paper industry, some products in thicknesses of less than 0.75 mm are termed “paperboard”. Such products are included within the scope of these methods.

1.1.4 These test methods are applicable to flexible fibrous-mat materials formed from suspensions of fiber in fluids other than water. These mats may have thicknesses approaching 2 mm, and may contain fibers that are natural, synthetic, organic, or inorganic; fillers that are natural, synthetic, organic, or inorganic; and flexible polymeric binder materials.

1.2 The procedures appear in the following sections:

Procedure	Sections	ASTM or TAPPI Reference (Modified)
Absorption (Rise of Water)	78 to 83	...
Acidity-Alkalinity-pH	45 to 54	E 70
Air Resistance	98 to 101	D 726
Aqueous Extract Conductivity	55 to 64	...
Ash Content	40 to 44	D 586
Bursting Strength	102 to 107	D 774
Chlorides (Water-Extractable)	165 to 183	...
Conditioning	15	D 6054
Conducting Paths	138 to 151	...
Density, Apparent	29 to 33	...
Dielectric Strength	152 to 157	D 149
Dimensions of Sheet, Rolls and Cores	16 to 24	D 374
Dissipation Factor and Permittivity	158 to 164	D 150
Edge-Tearing Resistance	126 to 130	D 827
Fiber Analysis	74 to 77	D 1030
Folding Endurance	108 to 110	T 423 and D2176
Grammage	25 to 28	D 646
Permittivity	158 to 164	D 150
Heat Stability in Air	131 to 137	D 827
Impregnation Time	84 to 91	...

<sup>1</sup> These test methods are under the jurisdiction of ASTM Committee D09 on Electrical and Electronic Insulating Materials and are the direct responsibility of Subcommittee D09.19 on Dielectric Sheet and Roll Products.

Current edition approved March 10, 1997. Published March 1998. Originally published as D202-24T. Last previous edition D202-92.

Current edition approved May 1, 2008. Published June 2008. Originally approved in 1924. Last previous edition approved in 2002 as D 202 – 97(2002)<sup>ε1</sup>.

\*A Summary of Changes section appears at the end of this standard.

Internal-Tearing Resistance	121 to 125	D 689 or T414
Moisture Content	34 to 39	D 644 and D3277
Particulate Copper	193 to 202	...
Particulate Iron	184 to 192	...
Reagents	4	D 1193
Reports	14	E 29
Sampling	6 to 13	D 3636
Silver Tarnishing by Paper and Paperboard	203 to 206	T 444
Solvent-Soluble Matter	65 to 73	...
Surface Friction	92 to 97	D 528 and T455
Tensile Properties	111 to 120	D 76, E4
Thickness (see Dimensions)	16 to 24	D 374

1.3 The tests for Holes and Felt Hair Inclusions and the Stain Test for Fine Pores, have been removed from this compilation of test methods. These test methods were specific to grades of capacitor paper formerly covered by Specification D 1930, which has been withdrawn.

NOTE 1—This compilation of test methods is closely related to IEC Publication 60554-2. Not all of the individual methods included herein are included in IEC 60554-2, nor are all of the methods in IEC 60554-2 included in this standard. The individual procedures as described in the two standards are in general sufficiently close to each other that it is reasonable to expect that test results obtained by most of the procedures specified in either standard will not differ significantly. However, before assuming that a procedure in these test methods is exactly equivalent to an IEC 60554-2 procedure, the written procedures should be compared closely, and if it seems advisable, test results by the two procedures should be compared.

#### 1.4

1.4 The values stated in SI units are to be regarded as standard. The values given in parentheses are mathematical conversions to SI units that are provided for information only and are not considered standard.

1.5 This standard does not purport to address all of the safety concerns, if any, associated with its use. It is the responsibility of the user of this standard to establish appropriate safety and health practices and determine the applicability of regulatory limitations prior to use. See 43.2.1, 71.1, 143.1, 148.1 and 156.1 for specific hazards.

## 2. Referenced Documents

### 2.1 ASTM Standards:<sup>2</sup>

- D 76 Specification for Tensile Testing Machines for Textiles
- D 149 Test Method for Dielectric Breakdown Voltage and Dielectric Strength of Solid Electrical Insulating Materials at Commercial Power Frequencies
- D 150 Test Methods for AC Loss Characteristics and Permittivity (Dielectric Constant) of Solid Electrical Insulating Materials<sup>3</sup>
- Insulation
- D 374 Test Methods for Thickness of Solid Electrical Insulation
- D 528 Test Method for Machine Direction of Paper and Paperboard
- D 586 Test Method for Ash in Paper<sup>4</sup>
- Test Method for Ash in Pulp, Paper, and Paper Products
- D 644 Test Method for Moisture Content of Paper and Paperboard by Oven Drying
- D 646 Test Method for Grammage of Paper and Paperboard (Weight/Mass Per Unit Area)
- D 689 Test Method for Internal Tearing Resistance of Paper
- D 726 Test Method for Resistance of Nonporous Paper to Passage of Air
- D 774/D 774M Test Method for Bursting Strength of Paper
- D 827 ~~Test Method for Edge-Tearing Resistance of Paper~~ Discontinued 1981; Method of Test for Edge Tearing Strength of Paper
- D 1030 Test Method for Fiber Analysis of Paper and Paperboard
- D 1193 Specification for Reagent Water
- D 1389 ~~Test Method for Proof-Voltage Testing of Thin Solid Insulating Materials<sup>3</sup>~~
- ~~D 1677~~ Methods for Sampling and Testing Untreated Mica Paper Used for Electrical Insulation<sup>3</sup> Test Method for Proof-Voltage Testing of Thin Solid Electrical Insulating Materials
- D 1711 Terminology Relating to Electrical Insulation
- D 2176 Test Method for Folding Endurance of Paper by the M.I.T. Tester
- D 2413 ~~Test Methods for Preparation and Electrical Testing of Insulating Paper and Board Impregnated with a Liquid Dielectric<sup>3</sup>~~
- ~~D 2753~~ Specification for Electrolytic Capacitor Paper<sup>3</sup> Practice for Preparation of Insulating Paper and Board Impregnated with a Liquid Dielectric
- D 2865 Practice for Calibration of Standards and Equipment for Electrical Insulating Materials Testing
- D 3277 Test Methods for Moisture Content of Oil-Impregnated Cellulosic Insulation
- D 3376 Test Methods of Sampling and Testing Pulp to be Used in the Manufacture of Electrical Insulation

<sup>2</sup> For referenced ASTM standards, visit the ASTM website, [www.astm.org](http://www.astm.org), or contact ASTM Customer Service at [service@astm.org](mailto:service@astm.org). For Annual Book of ASTM Standards, Vol 07-01 volume information, refer to the standard's Document Summary page on the ASTM website.

D 3394 Test Methods for Sampling and Testing Electrical Insulating Board  
 D 3636 Practice for Sampling and Judging Quality of Solid Electrical Insulating Materials  
 D 6054 Practice for Conditioning Electrical Insulating Materials for Testing  
 E 4 Practices for Force Verification of Testing Machines  
 E 29 Practice for Using Significant Digits in Test Data to Determine Conformance with Specifications  
 E 70 Test Method for pH of Aqueous Solutions ~~with~~With the Glass Electrode

2.2 *TAPPI Standards:*

~~T 413 Ash in Paper and Paperboard~~<sup>3</sup>  
 T 414 Internal Tearing Resistance of Paper  
 T 423 Folding Endurance of Paper (Schopper Type Test)  
 T 444 Silver Tarnishing by Paper and Paperboard  
 T 455 Identification of Wire Side of Paper  
 T 460 Air Resistance of Paper (Gurley Method)  
 T 470~~Edge Tearing Resistance of Paper~~ Edge Tearing Resistance of Paper  
 T 536 Resistance of Paper to Passage of Air (High Pressure Gurley Method)

2.3 *IEC Standard:*

IEC 60554-2 Specification for cellulosic papers for electrical purposes—Part 2: Methods of test<sup>4</sup>

### 3. Terminology

3.1 *Definitions:*

3.1.1 For definitions pertaining to sampling refer to Terminology D 1711 or to Practice D 3636.

3.1.2 For definitions pertaining to dissipation factor and permittivity refer to Terminology D 1711 or to Test Methods D 150.

3.2 *Definitions of Terms Specific to This Standard:*

3.2.1 *air resistance, of paper, n*—a paper property which quantifies impediment to the transverse passage of air through the paper under specific conditions of test, and reported as either time for a specified volume per area of test or volume for a specified time per area of test.

3.2.1.1 *Discussion*—It is expressed in terms of time (seconds) required for passage of a specified volume of air through a known area of paper, or, as the volume of air passing through the paper in a given length of time.

3.2.2 *ash content of paper, n*—the solid residue remaining after combustion of the paper under specified conditions, expressed as a percentage of the dry mass of the original specimen.

3.2.3 *basis weight of paper*—see *grammage of paper*.

3.2.4 *bursting strength of paper, n*—the hydrostatic pressure required to produce rupture of a circular area of the material under specified test procedures.

3.2.5 *coverage of paper, n*—the reciprocal of grammage (or basis weight).

3.2.6 *elongation of paper, n*—the maximum tensile strain developed in the test specimen before break in a tension test under prescribed conditions, calculated as the ratio of the increase in length of the test specimen to the original test span, and expressed as a percentage.

3.2.6.1 *Discussion*—It is calculated as the ratio of the increase in length of the test specimen to the original test span, and is expressed as a percentage.

3.2.7 *folding endurance of paper, n*—the resistance to fatigue resulting from repeated folding under specified conditions of test, expressed as the number of double folds required to rupture a specimen, or as the logarithm of that number.

3.2.7.1 *Discussion*—The level is expressed as the number of double folds required to rupture a specimen. Sometimes the level is expressed as the logarithm of the number.

3.2.8 *grammage of paper, n*—the mass per unit area of paper, expressed as grams per square metre.

3.2.8.1 *Discussion*—Grammage is sometimes called weight or basis weight of paper. These terms are most frequently used when non-metric units are used, and the area is that of the paper in one of the several standard reams of papers defined within the paper industry.

3.2.9 *impregnation time of paper, n*—the time in seconds required for a liquid of specified composition and viscosity to penetrate completely from one face of a sheet of paper to the other under certain prescribed conditions.

3.2.10 *internal tearing resistance of paper, n*—the force required to continue a previously-initiated tear across a specified distance in a single thickness of paper, expressed as the average force per sheet to tear one or more sheets together.

3.2.10.1 *Discussion*—It is indicated on the specified apparatus and reported as the average force per sheet to tear one or more sheets together across a specified distance.

<sup>2</sup> Annual Book of ASTM Standards, Vol 10.01.

<sup>3</sup> Available from Technical Association of the Pulp and Paper Industry (TAPPI), 15 Technology Parkway South, Norcross, GA 30092, <http://www.tappi.org>.

<sup>4</sup> Annual Book of ASTM Standards, Vol 15.09.

<sup>4</sup> Available from Global Engineering Documents, 15 Inverness Way, East Englewood, CO 80112-5704, <http://www.global.ihs.com>.

3.2.11 *loss on ignition of inorganic fiber paper, n*—the volatile and combustible fraction of a paper, expressed as a percentage of the original dry mass lost upon ignition, using a specified procedure.

3.2.11.1 *Discussion*—It is expressed as a percentage of the original dry weight lost upon ignition, and is usually used instead of ash content when dealing with papers which are principally composed of inorganic fibers.

3.2.12 *solvent-soluble material in paper, n*— the mass of material that can be extracted from a dry specimen by a specified solvent under prescribed conditions, expressed as a percentage of the original dry mass.

3.2.13 *kinetic surface friction of paper, n*— the ratio of the force parallel to the surfaces of two pieces of paper in contact with each other to the force normal to the surfaces required to continue previously-initiated movement relative to each other at constant speed.

3.2.13.1 *Discussion*—The test may be made using a paper-covered block on a paper-covered inclined plane, in which case the result is expressed in degrees of angle of inclination of the plane which will cause the block to continue an initiated movement.

3.2.14 *tensile energy absorption of paper (TEA), n*—the work performed when a paper specimen is stressed to break in tension under prescribed conditions, as measured by the integral of the tensile stress over the range of tensile strain from zero to the strain corresponding to maximum stress, expressed as energy (work) per unit of original surface area of the test specimen.

3.2.14.1 *Discussion*—The TEA is expressed as energy (work) per unit of original surface area (length  $\times$  width) of the test specimen.

3.2.15 *tensile strength of paper, n*—the maximum tensile stress developed in a test specimen in a tension test carried to break under prescribed conditions, expressed for thin papers as force per unit original width of the test specimen.

3.2.15.1 *Discussion*—Tensile stress is the force per unit of original cross-sectional area, but in thin materials such as paper it is commonly expressed in terms of force per unit of original width.

3.2.16 *thickness of an electrical insulating material, n*—the perpendicular distance between the two surfaces of interest, determined in accordance with a standard method.

3.2.16.1 *Discussion*—The thickness of papers under 0.05 mm (0.002 in.) in thickness, is often defined as one tenth that of a stack of ten sheets in certain paper specifications.

3.2.17 *water extract conductivity of paper, n*—the apparent volume conductivity at 60 Hz of a specimen of water that has been used to dissolve water-soluble impurities from a specimen of paper under prescribed conditions.

## 4. Reagents

4.1 *Purity of Reagents*—Use reagent grade chemicals in all tests. Unless otherwise indicated, it is intended that all reagents conform to the specifications of the Committee on Analytical Reagents of the American Chemical Society, where such specifications are available.<sup>5</sup> Other grades are acceptable, provided it is first ascertained that the reagent is of sufficiently high purity to permit its use without lessening the accuracy of the determination.

4.2 *Purity of Water*—Except where otherwise indicated, use reagent water, Type III, of Specification D 1193.

## 5. Precision and Bias

5.1 For individual test methods that follow, where no precision and bias section is included and where the procedure is contained in another standard to which reference is made, refer to that standard for information relative to precision and bias for that test method.

## SAMPLING

### 6. Scope

6.1 This test method covers the procedure for judging lot acceptability of electrical insulating papers. It is designed for the purpose of determining acceptability of all or that portion of a shipment to a customer identified by a manufacturer's lot number. It is not intended to cover internal paper mill quality control plans. This test method is intended for use in conjunction with product specifications for electrical insulating papers.

### 7. Summary of Test Method

7.1 After Acceptable Quality Levels (AQLs) are agreed upon for each of the various specification properties, sampling plans are selected and the basis for acceptance or rejection of a lot of material is established.

### 8. Significance and Use

8.1 In the buyer-seller relationship it is necessary that an understanding exists as to the expected nominal characteristics of the product, and the magnitude of permissible departure from the nominal values. Also, it is necessary that an agreement be reached as to how many units of a lot can fall outside of the specification limits without rejection of the lot. It is this latter subject that is addressed by this test method.

<sup>5</sup> Discontinued 1981. See Annual Book of ASTM Standards, Vol 15.09.

<sup>5</sup> "Reagent Chemicals, American Chemical Society PO Box 182426, Columbus, OH 43218-2426." For suggestions on the testing of reagents not listed by the American Chemical Society, see "Reagent Chemicals and Standards," by Joseph Rosin, D. Van Nostrand Co., Inc., New York, NY, and the "United States Pharmacopeia."

## 9. Establishing AQLs

9.1 AQLs for each critical major and minor property are as mutually agreed upon between the manufacturer and the customer. If needed, establish group AQLs for given groups of properties; these too are mutually agreed upon between the manufacturer and the purchaser.

## 10. Selection of Samples

10.1 A number of paper properties are listed in Table 1, together with the appropriate number of test specimens and test measurements for each property. Use these values for guidance in determining sample sizes.

10.2 From Table 2 select a sampling plan appropriate to the lot size and the agreed-upon AQL. Alternatively, refer to Practice D 3636 for selection of a sampling plan. Refer to Practice D 3636 for further information relative to the principles and practices of sampling methods.

10.3 Inasmuch as several properties of paper (notably moisture content and aqueous extract conductivity) may change with time, define a reasonable maximum time between receiving a lot of paper and testing it for such properties, either in the material specification or by agreement between the seller and the purchaser.

10.4 For purposes of sampling for lot acceptance or rejection, select the number of units of product from each lot in the shipment in accordance with sampling plans selected from 10.2. Select units of product at random so as to be representative of the lot. Take care to avoid selection of all units of product from the top or bottom, one side or the other, or from any specific location in the lot.

10.5 If more than one lot sample size is used, first determine those properties measured from the smaller sample, after which this sample may be included as part of the larger sample.

### 10.6 Selecting Test Unit from Unit of Product:

10.6.1 For units of product consisting of rolls 380 mm (15 in.) or more in width, take a test unit at least 0.5 m<sup>2</sup> (5 ft<sup>2</sup>) in area, cut across the entire width of the roll.

10.6.2 Cut test specimens from this area such that they represent the entire width of the roll.

10.6.3 If the paper is available in rolls less than 380 mm in width, take a test unit at least 1.25 m (4 ft) in length and cut test specimens so as to be representative of the full width of the roll.

10.6.4 When the unit of product is defined as a sheet, take the test unit from the sheet so that the entire width and length of the sheet are represented.

10.6.5 Where the unit is defined as a skid, pallet, box, carton, case, package, bundle, or ream and contains paper in the following forms:

10.6.5.1 *Sheet Form*—Take the test unit in such a way that each test specimen is cut at random from the sheet and each sheet is taken at random throughout the unit of product in order that the test unit is representative of the unit of product (wherever applicable). Exclude the first 12 mm (½ in.) of paper from the top or bottom (or ends) from the sampling.

10.6.5.2 *Roll, Pad, or Bobbin Form*—Select the test unit at random from the rolls that make up the unit of product. (Do not include the first few turns of each roll as part of the test unit.)

## 11. Identification of Lot Sample Pieces

11.1 Mark each unit of product of the sample so that it can be identified at any time.

**TABLE 1 Number of Test Specimens per Test Unit; Number of Test Measurements per Test Specimen**

Property	Unit of Product—Roll, Pad, Bobbin, or Sheet		Unit of Product—Skid, Pallet, Box, Carton, Case, Package, Bundle, or Ream	
	Number of Test Specimens per Test Unit	Minimum Number of Test Measurements per Test Specimen	Number of Test Specimens per Test Unit	Minimum Number of Test Measurements per Test Specimen
Aqueous extract conductivity, acidity-alkalinity-pH, ash, moisture, solvent-soluble matter, chlorides, fiber analysis, surface friction	2	1	2	1
Basis weight, bursting strength, folding endurance, tensile properties, absorption	10	1	10	1
Thickness, dielectric strength <sup>A</sup>	1	5 <sup>A</sup>	5	1
Holes and felt hair inclusions, dissipation factor, density, dry coverage, core dimensions, sheet squareness	1	1	1	1
Conducting paths	5	1	5	1
Tearing strength	5	1	5	1
Air resistance <sup>A</sup>	1 <sup>A</sup>	10 <sup>A</sup>	10	1
Impregnation time	6	1	6	1
Heat stability:				
If folds or edge tear are used	10	1	10	1
If internal tear is used	5	1	5	1
Roll width, sheet dimensions	1	2	1	2

<sup>A</sup> Indicates exception to number of specimens and test called for by the test method.

**TABLE 2 Sampling Plans**

Lot Sample Size	Acceptance Number	Rejection Number	Lot Tolerance Percent Defective ( $P_d$ )
AQL = 2.0 % (1.5 to 2.5) <sup>A</sup>			
15	1	2	24
20	1	2	18
30	1	2	12.5
35	2	3	14.5
40	2	3	12.8
50	2	3	10.5
AQL = 4.0 % (2.6 to 5.0) <sup>A</sup>			
7	1	2	45
10	1	2	34
20	2	3	24
30	3	4	21
35	3	4	18
40	3	4	16
50	3	4	13
AQL = 8.0 % (5.1 to 10.0) <sup>A</sup>			
5	1	2	58
10	2	3	45
15	2	3	32
20	3	4	30
25	3	4	25

<sup>A</sup> Refers to the range of AQL's covered.

## 12. Lot Disposition

12.1 If the lot sample fails to meet the requirements for acceptability, the entire lot is subject to rejection.

## 13. Waiver of Requirements

13.1 The customer may agree to waive requirements with respect to the sampling plans, conducting of tests, applicable property specified limits, or lot rejection.

## REPORTS

### 14. Report

14.1 At the completion of testing, report the test results of the paper properties with identifying units on a report form that includes the following:

14.1.1 Identification of the paper sampled and tested by lot number, type, grade, etc.,

14.1.2 Dates of testing,

14.1.3 Location of the testing laboratory and the person responsible for the testing,

14.1.4 Remarks indicating test method or procedure used and the deviation, if any, from the standard test procedures, and

14.1.5 Indication of the variance in test measurements such as range, standard deviation,  $\sigma$ , etc.

14.2 Report the test results either as calculated or observed values rounded to the nearest unit in the last right-hand place of figures used in the material specification to express the tolerances. (See the rounding Method of Practice E 29).

## CONDITIONING

### 15. Conditioning

15.1 Condition samples in air at  $50 \pm 2$  % relative humidity at a temperature of  $23 \pm 2$  °C ( $73.4 \pm 3.6$  °F). Hold the samples in the conditioned air for not less than 4 h prior to the tests, and support them so as to allow a free circulation around each sample. (See Practice D 6054).

15.2 Make the following physical tests in the conditioned atmosphere: thickness, basis weight, tensile strength, stretch under tension, internal tearing resistance, bursting strength, folding endurance, absorption, air resistance, impregnation time, dimensions, surface friction, and edge-tearing resistance.

15.3 For work of such precision that the hysteresis in the equilibrium moisture content may lead to appreciable error, approach the moisture content equilibrium under standard conditions from a drier state, following the preconditioning provisions in Practice D 6054.

## DIMENSIONS OF SHEETS, ROLLS, AND CORES

### 16. Scope

16.1 These test methods cover procedures for the determination of dimensions of sheets of electrical insulating paper; rolls of

electrical insulating paper; and cores upon which rolls of paper are wound.

16.2 The length of any sheet is the dimension measured in the machine direction of the paper, and the width of the sheet is the dimension measured in the cross-machine direction. The thickness of any sheet is as defined in ~~3.1-18~~ Terminology D 1711.

## 17. Summary of Test Method

### 17.1 Thickness measurements:

17.1.1 Three types of micrometers may be used for these measurements; machinist's micrometer with ratchet, dead-weight dial micrometer, or motor-operated micrometer.

17.1.2 Measurements are made in prescribed manners, using the micrometer designated for a particular case. The use of a machinist's micrometer is not recommended except for screening or rough measurements to be later confirmed by the more accurate instruments designated herein.

17.2 *Sheet Length and Width, and Roll and Core Dimensions*—Steel scales, vernier calipers, or go-no-go gages are used with conventional techniques to determine the width, length, and squareness of sheets, the width and diameter of rolls, and the inside and outside diameters of cores.

## 18. Significance and Use

18.1 Accurate determination of thickness is important both for acceptance tests and for design purpose. The number of layers of paper required for a certain overall thickness of insulation depends on this dimension. Since apparent density is a function of weight per unit area and thickness, the latter must be known in order to calculate apparent density. Thickness enters into the calculation of dielectric strength, resistivity, and other electrical properties.

18.2 Essentially all paper is purchased with the other dimensions of the sheet or roll specified, with tolerances on these dimensions. Compliance with these requirements is usually necessary for trouble-free use of the paper in manufacturing operations.

18.3 The dimensions of rolls and of the roll cores determine the weight that must be handled, and if the roll will physically fit on the payoff stand of the equipment on which it will be further processed.

## 19. Apparatus

### 19.1 Thickness:

19.1.1 Determine the thickness using any one of the following apparatus:

19.1.1.1 *Method A—Machinist's Micrometer* with ratchet or equivalent, as described in the Apparatus Section of Test Methods D 374.

19.1.1.2 *Method C—Dead-Weight Dial Micrometer*, as described in the Apparatus Section of Test Methods D 374. This apparatus is not to be used for papers under 0.05 mm (0.002 in.) in nominal thickness.

19.1.1.3 *Method D—Motor-Operated Micrometer*, conforming to the following requirements. The apparatus shall be a dead-weight (not spring-) actuated, dial-type, motor-operated micrometer. It shall conform to the apparatus described in the Apparatus Section (Method B) of Test Methods D 374, except that the capacity shall exceed 0.8 mm (0.03 in.). Design the motor-operating mechanism that controls the lowering of the presser foot to ensure that the loading on the specimen created by the falling presser foot is below the loading created by a free-falling presser foot dropped from a height of 0.008 mm (0.0003 in.) above the specimen surface.

NOTE 2—For example, any free-falling body dropped from a height of 0.008 mm will attain a maximum theoretical velocity of approximately 12 mm/s (0.5 in./s). A presser foot dropping at a controlled velocity of 0.8 to 1.5 mm/s (0.03 to 0.06 in./s) will create a loading equivalent to the loading produced by a free-falling pressor foot dropped from heights of 0.000028 to 0.000119 mm (0.000001 to 0.000005 in.).

19.1.2 Calibrate micrometers in accordance with the Calibration Section of Test Methods D 374.

### 19.2 Other Measurements:

19.2.1 *Scale*—A machinist's precision steel scale of suitable length graduated to read within the accuracy specified for the sheet or roll size tolerances. A similar scale of suitable length is also required to measure diagonals of sheets.

19.2.2 *Calipers*—A machinist's vernier caliper of suitable size graduated to read within the degree of accuracy specified for the inside diameter tolerances of the core.

19.2.3 The measuring scales and calipers shall be graduated so that half of the specified tolerance can be read directly, that is, if the tolerance is 1.0 mm (or  $\frac{1}{32}$  in.) then the scale shall be graduated to at least 0.5 mm (or  $\frac{1}{64}$  in.)

19.2.4 *Gages*—A set of two gages ("go" and "no-go") for each size core. Each gage in a set shall have a diameter within  $\pm 0.005$  mm (0.0002 in.) of the specified maximum or minimum diameter.

## 20. Sampling

20.1 Sample in accordance with Sections 6 to 13.

## 21. Test Specimens

21.1 Take test specimens of sheets from the original samples, conditioned flat in accordance with Section 15.

21.2 For papers over 0.051 mm (0.002 in.) in nominal thickness use a single sheet as a test specimen for thickness measurements.

21.3 For papers 0.051 mm (0.002 in.) and under in nominal thickness, the specimen for thickness measurements may be a single sheet or a stack of ten sheets as mutually agreed upon between the purchaser and the supplier.

NOTE 3—In selecting the options given in 21.2 and 21.3, several factors are hereby given for consideration: (1) Greater reliability of micrometer measurements is achieved when measurements are made on stack specimens. (2) The thickness of a ten-sheet stack of paper does not necessarily bear a constant relationship to the thickness of a single sheet. (3) Variations in a single-sheet thickness are largely hidden in stack measurements. (4) Differences between measurements are greater on single-sheet specimens than on stack specimens.

21.4 Use a single sheet as the test specimen for length, width, and squareness of sheets.

21.5 For paper in roll form, use the entire roll as a specimen. It is not necessary to condition this specimen prior to dimension measurements.

## 22. Procedure

### 22.1 Thickness:

#### 22.1.1 Requirements Applicable to all Methods:

22.1.1.1 The procedure for using any micrometer requires the presser foot and anvil surfaces be clean during measurements, that proper calibration operations are performed, including the construction of a calibration curve if necessary; and that dial-type micrometers be mounted on a solid level surface free of excessive vibration.

22.1.1.2 When the width of the sample permits, make all measurements with edges of the presser foot and the anvil at least 6 mm (0.25 in.) away from the edges of the specimen.

22.1.1.3 Take a specified number of measurements (mutually agreed upon between the purchaser and the supplier) at regular intervals across the entire width of each specimen, preferably in a line that is at right angles to the machine direction of the paper. In all cases make at least five such measurements. Apply the deviations for the parts of the scale corresponding to the paper thickness measured as corrections to the thickness reading.

22.1.1.4 When using multiple-sheet test specimens, do not place the presser foot closer than 20 mm (0.75 in.) from any folded edge of the stack.

22.1.2 *Method A*—Determine the thickness in accordance with the Procedure Section of Test Methods D 374.

#### 22.1.3 *Method C*:

22.1.3.1 Place the specimen between the contact surfaces and lower the presser foot onto the specimen at a location outside of the area to be measured. This will indicate the approximate thickness so that the conditions set forth herein can be maintained.

22.1.3.2 Raise the presser foot, move the specimen to the measurement position, and lower the presser foot to 0.0075 mm (0.0003 in.) above the thickness obtained on the first determination; then let the presser foot drop.

22.1.3.3 For each succeeding measurement raise the presser foot, move the specimen to the next measurement location, and lower the presser foot to 0.0075 mm above the thickness obtained on the first determination before letting the presser foot drop.

22.1.3.4 An alternative technique is to lower the presser foot at some velocity less than 13 mm/s (0.5 in./s) onto the surface of the paper specimen.

22.1.3.5 When making thickness measurements, maintain the presser foot dead weight loading on the test specimen for at least 2 s, but not more than 4 s before taking the reading.

NOTE 4—The procedure described in 22.1.3 minimizes small errors present when the presser foot is lowered slowly onto the specimen.

NOTE 5—When measuring the thickness of noticeably compressible papers, the purchaser and the supplier may wish to fix the exact time, within the above limits, that the pressure is applied to the test specimen.

22.1.4 *Method D*—Using the motor-operated micrometer, follow the procedures described in 22.1.3. Place the specimens between the presser foot and the anvil and obtain thickness readings. When making thickness measurements, maintain the deadweight loading on the test specimen for at least 2 s but not more than 4 s before taking a reading.

NOTE 6—When measuring the thickness of noticeably compressible papers, the purchaser and the supplier may wish to fix the exact time, within the above limits, that the proper pressure is applied to the test specimen as well as the exact velocity of the fall of the presser foot.

22.2 *Length and Width of Sheets*—Measure the length and width of the specimen to the nearest appropriate unit. Make two measurements in each dimension.

22.3 *Squareness of Sheets*—Measure the lengths of both diagonals of the sheet.

### 22.4 Roll Dimensions:

22.4.1 Measure the width of the specimen to the nearest appropriate unit. Make at least two measurements.

22.4.2 Measure the outside diameter of the specimen at least two points on each end of the roll.

### 22.5 Core Dimensions:

22.5.1 Measure the inside core diameter at each end with go-no-go gages to determine whether the core meets the minimum and maximum specified diameters. Measure cores having diameters outside of the specified limits at least two points on each end with an inside feeler gage or the vernier calipers.

22.5.2 Measure the outside core diameter at least two points on each end with the vernier calipers.

## 23. Calculation and Report

23.1 Report in accordance with Section 14, and include the following information, as applicable:



### 23.1.1 Thickness:

23.1.1.1 Report the average, the minimum, and the maximum of the individual readings for single-sheet specimens.

23.1.1.2 For multiple-sheet test specimens, divide the micrometer readings by the number of sheets in the specimen stack and use the resulting quotient as the individual “single sheet” thickness. In all cases where multiple-sheet stacks are used report the number of sheets in the stack.

23.1.2 *Sheet Size*, reported as the average of the measurements in each dimension.

23.1.3 *Squareness*, reported as the difference in the lengths of the diagonals divided by the shorter length.

### 23.1.4 Roll Dimensions:

23.1.4.1 *Roll Width*, reported as the average of the measurements for each specimen and,

23.1.4.2 *Roll Diameter*, reported as the average of the measurements for each specimen.

### 23.1.5 Core Dimensions:

23.1.5.1 Number of cores that were within the limits of the go-no-go gages and the number that exceeded the limits of the go-no-go gages,

23.1.5.2 Measured inside diameters of cores not within the limits for inside diameter (if specified) and,

23.1.5.3 Average outside diameter of cores (if specified).

## 24. Precision and Bias

24.1 *Precision*—This test method has been in use for many years, but no statement for precision has been made, and no activity is planned to develop such a statement.

24.2 *Bias*—A statement of bias cannot be made because of the lack of a standard reference material.

## GRAMMAGE (WEIGHT PER UNIT AREA) AND DRY COVERAGE

### 25. Scope

25.1 This test method covers the determination of the weight (or mass) per unit area of paper.

25.2 The weight per unit area is reported in any of several units, such as grams per square metre, pounds per square foot (or per 1000 square feet), or pounds per ream. For most paper products these are the more customary units. Test Method D 646 provides conversion factors for calculating results in these units.

### 26. Summary of Test Method

26.1 The area of several sheets of paper is determined from linear measurements and the mass (commonly called “weight”) is determined by weighing. The grammage is calculated from the ratio of the mass to the area.

### 27. Significance and Use

27.1 Knowledge of the grammage is useful in the selection of materials for economical design purposes, product specification, and routine area calculations.

### 28. Procedure

28.1 *Grammage*—Determine the grammage in accordance with Test Method D 646, except sample the material in accordance with Sections 6 to 13 of these test methods. Report the results in grams per square metre, or as otherwise specified.

28.2 *Dry Coverage*—Proceed as in 28.1, cutting the specimen to the prescribed dimensions after conditioning in accordance with Section 15, and then drying the specimens to constant weight using the techniques described in Test Method D 644. Calculate the coverage as square metres per gram of oven-dry weight.

NOTE 7—Commercially, coverage is expressed as square inches per pound of oven-dry weight. Multiply square metres per gram of oven-dry weight by  $703 \times 10^{-3}$  to convert to commercially used units.

## APPARENT DENSITY

### 29. Scope

29.1 This test method covers procedures for measuring and calculating the apparent density of paper. Two test methods for calculating and reporting the density are described.

29.2 See also the procedures given in Section 163, relating density to dissipation factor and permittivity.

### 30. Summary of Test Method

30.1 The volume and the weight of the test specimen are determined and used to calculate the density of the specimen in grams per cubic centimetre. Either the conditioned weight or the oven-dried weight of the specimen is used, as specified.

### 31. Significance and Use

31.1 The apparent density of untreated paper used for electrical insulating purposes describes the weight-to-volume ratio of the paper, the weight and volume being determined according to certain prescribed conditions. A knowledge of this property is useful

in the design of electrical insulating systems and in determining the economic aspects of paper use. Many physical and electrical properties of paper are related to apparent density.

### 32. Procedure

32.1 *Procedure A, Wet-Wet Density*—Prepare three rectangular test specimens, of such size that the width and length can be measured to within  $\pm 1\%$ . Condition the specimens in accordance with Section 15. Measure the thickness, length, and width in accordance with Sections 16 to 24. Determine the weight and calculate the density. The average density of the three specimens is the test result.

NOTE 8—If the dimensions are measured in inches, multiply the calculated volume in cubic inches by 16.387 to obtain cubic centimetres.

32.2 *Procedure B, Wet-Dry Density*—The technique for obtaining wet-dry apparent density is identical with that described in 32.1, except obtain the weight of the specimens after drying to a constant weight in an oven at  $105 \pm 3^\circ\text{C}$  as in Test Method D 644.

### 33. Precision and Bias

33.1 *Precision*—The precision of this test method has not been determined. However, it is dependent upon the precision with which the four separate measurements entering into the calculations are made, and upon the atmospheric conditions, particularly the relative humidity, in which the specimens are conditioned prior to test.

33.2 *Bias*—A statement of bias is not practicable because of lack of a standard reference material.

## MOISTURE CONTENT

### 34. Scope

34.1 This test method covers two procedures for determining the mass percent of moisture in paper. The oven-drying procedure is used for most applications, and the solvent-extraction procedure is for oil-impregnated samples.

### 35. Summary of Test Method

35.1 *Oven-Drying Procedure*—Specimens of paper are weighed initially and after oven drying to equilibrium weight. The moisture content is calculated as a percentage of the initial weight.

35.2 *Solvent-Extraction Procedure*—Water is extracted from the specimen using an organic solvent. The water content of the solvent is then determined using the Karl Fischer titration procedure.

### 36. Significance and Use

36.1 A knowledge of moisture content is necessary to calculate, to a dry basis, analytical results obtained from conditioned specimens. The moisture content affects cost when purchasing papers, and is important in the design of electrical insulating systems, since it affects properties such as shrinkage characteristics. Moisture content has a significant effect on many of the physical, electrical, and thermal aging properties of insulating papers, including runability on processing equipment.

36.2 For applications involving paper in manufacturing, fabricating, and converting operations, use the oven-drying procedure (Procedure A). This includes virtually all specification and quality control, and many research situations.

36.3 For paper impregnated with insulating fluid, or subjected to a drying operation, the solvent-extraction procedure (Procedure B) may be applicable. In most cases this will be in research or trouble-shooting applications.

### 37. Sampling and Preparation of Test Specimens

37.1 Sample in accordance with Sections 6 to 13 of these test methods.

37.2 Use procedures for sampling and specimen preparation such that exposure of the test material to the open air, and resultant changes in moisture content, are minimized.

37.3 Prepare test specimens as specified in Test Method D 644 or Test Method D 3277, as applicable.

### 38. Procedures

38.1 *Procedure A*—Determine the moisture content in accordance with Test Method D 644.

38.2 *Procedure B*—Determine the moisture content in accordance with Method D 3277, using Method A or Method B of that method, as applicable.

### 39. Report

39.1 Report the moisture content as a percentage of the initial weight of the specimen, or, in the case of oil-impregnated materials, in accordance with Test Method D 3277.

39.2 Report in accordance with Section 14, and the report section of Test Method D 644 or Test Method D 3277, as applicable.

## ASH CONTENT

### 40. Scope

40.1 This test method covers two procedures: *Procedure A* for the determination of the noncombustible portion of paper, usually

applied to cellulosic papers which have a small amount of residue after combustion; and *Procedure B* for the determination of loss on ignition of papers having high percentages of inorganic material and which do not entirely lose their physical integrity during ignition.

#### 41. Summary of Test Methods

41.1 *Procedure A*—The weighed, oven-dried specimen is ignited at a constant temperature in a covered crucible to constant weight. The weight of the noncombustible residue is determined and expressed as a percentage of the original oven-dried weight.

41.2 *Procedure B*—A gas burner is used to burn off volatile matter from an oven-dried specimen held in the burner flame. The weight loss during this procedure is determined and expressed as a percentage of the original weight.

#### 42. Significance and Use

42.1 The ash determination is a relatively simple and convenient method to detect the presence of inorganic fillers, coatings, pigments, or contaminants in paper. This test method is also useful to prepare specimens for the quantitative determination of inorganic constituents in paper. This procedure is suitable for control testing, research, and referee analysis. The specified ashing temperature is selected to minimize loss of those inorganic constituents that are volatile at higher ashing temperatures.

42.2 The loss-on-ignition procedure is useful as a quality control test for papers having high levels of inorganic materials in their structures. Do not use for papers having volatile or combustible contents greater than 75 %.

#### 43. Procedure

43.1 *Procedure A*—Determine the ash content in accordance with Test Method D 586, except use  $575 \pm 25$  °C as the ashing temperature.

43.2 *Procedure B*:

43.2.1 **Precaution** **Warning**—Perform this test in an exhausted fume hood. Avoid inhaling any of the products of combustion.

43.2.2 Cut a specimen approximately 100 by 150 mm (4 by 6 in.). Oven dry the specimen to constant weight at  $100 \pm 5$  °C. Record the oven dry weight ( $W_{od}$ ) to the nearest milligram.

43.2.3 Burn off the volatile matter over a Meker-type burner in such a manner as to avoid melting the inorganic fibers and thus entrapping volatiles. A properly ignited residue appears white with no trace of carbon residue.

43.2.4 After burning off the volatiles, cool the specimen and immediately weigh it to the nearest milligram. This is the ash weight ( $W_a$ ).

43.2.5 Calculate the percent loss on ignition:

$$\% \text{ loss on ignition} = (W_{od} - W_a) / W_{od} \times 100 \quad (1)$$

43.2.6 Report the loss on ignition to the nearest 0.1 %, in accordance with Section 14.

#### 44. Precision and Bias

44.1 For the precision and bias of Procedure A, refer to Test Method D 586.

44.2 The precision of Procedure B has not been determined, and no activity is planned to determine its precision.

44.3 Procedure B has no bias because the loss on ignition is defined in terms of this test method.

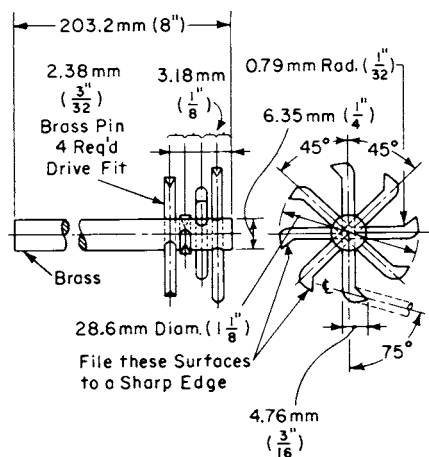

FIG. 1 Stirrer

### ACIDITY-ALKALINITY-pH

#### 45. Scope

45.1 This test method is designed to indicate the active and the total acidity or alkalinity of an aqueous extract of electrical

insulating papers. Since the aqueous extracts of most untreated papers used for electrical insulation are normally unbuffered and are readily affected by atmospheric conditions, this method embodies features to minimize error from this source.

#### 46. Summary of Test Method

46.1 This test method consists of a hot-water extraction of the specimen followed by a pH measurement or an alkalinity-acidity titration of the extract solution.

#### 47. Significance and Use

47.1 The pH determination measures the extent to which the paper alters the hydrogen-hydroxyl ionic equilibrium of pure water. The acidity-alkalinity determination measures the quantity of extracted ionic material that contributes to that equilibrium change. Such constituents may represent potential shortcomings, either initially, or after prolonged service, of electrical equipment using this paper. These tests are useful for routine acceptance testing, research work or in the evaluation of different materials.<sup>6</sup>

#### 48. Apparatus

48.1 *Bath*—A hot-water bath.

48.2 *Motor and Stirrer*—A motor with a stirrer constructed as shown in Fig. 1. Use an acid- and alkali-resistant stirrer. Chromium-plated brass is a suitable material.

48.3 *Thermometers*—Thermometers having a range from 50 to 100 °C and graduated in 1° intervals.

48.4 *Buret*—A 10-mL buret graduated to 0.05 mL.

48.5 *Electric Hot Plate*.

48.6 *Suction Filtering Apparatus*.

48.7 *pH Meter*—A pH meter conforming to the requirements prescribed in Test Method E 70.

#### 49. Reagents

49.1 *Purity of Water*—Use water in this test method that meets the requirements described in 4.2, and is free of carbon dioxide, and with a pH between 6.2 and 7.2 at 25 °C.

49.2 *Buffer Solution, Standard (for standardizing the glass electrode)*—Dry about 6 g of potassium acid phthalate for not less than 2 h at 120 °C. Cool in a desiccator. Add 5.0905 g of the salt to 500 mL of water at 25 °C. The pH of this buffer solution is 4.0 at 25 °C.

49.3 *Indicator Solution*—Add approximately 500 mg of neutral red to 300 mL of denatured ethanol. When it is thoroughly dissolved, dilute with ethanol to 500 mL in a volumetric flask. Stopper the flask and allow to age overnight at room temperature. Filter the aged liquid through a fritted glass filter using suction if necessary. Measure the pH of this solution and, if necessary, adjust to pH 7.0 by the addition of 0.10 N NaOH solution.

49.4 *Sodium Hydroxide, Standard Solution (0.005 N)*—Dissolve 0.2 g of sodium hydroxide (NaOH) in water and dilute to 1 L in a volumetric flask. To standardize, prepare 250 mL of a 0.005 N potassium acid phthalate solution by dissolving 0.2552 g of the dried salt in water and making up to the mark in a 250-mL volumetric flask at 20 °C. (Do not dry the salt at a temperature above 125 °C). Pipet 25 mL of this solution into a 250-mL flask. Add 25 mL of water. Immerse the pH electrode or if an indicator is used, add a few drops of indicator solution. Pass nitrogen through the solution for 10 min. Titrate in a closed system with the standard NaOH solution to pH 7 or to an orange shade. If preferred, the potassium acid phthalate solution may be heated to boiling and titrated immediately, taking care that the temperature does not fall below 80 °C during the titration. Run three specimens in the above way at each standardization of the NaOH solution. Determine a blank on the same volume of water and indicator and deduct from the titration obtained above. Calculate the normality of the NaOH solution as follows:

$$\text{Normality of NaOH solution} = (25 \times 0.005)/\text{mL} + \text{NaOH solution required} \quad (2)$$

NOTE 9—Good laboratory practice requires use of a freshly prepared and standardized NaOH solution.

49.5 *Sulfuric Acid, Standard (0.005 N)*—Prepare 0.005 N sulfuric acid (H<sub>2</sub>SO<sub>4</sub>) and determine the alkali equivalent of the acid as follows: Transfer 10 mL of the acid to a 250-mL Erlenmeyer flask and dilute with 100 mL of water. Titrate in a closed system or at the boiling point with the standard NaOH solution as described in 49.4 for the standardization of the NaOH solution. Determine a blank on the same volume of water and indicator solution and deduct from the titration obtained above. Calculate the NaOH equivalent of the acid as follows:

$$E = A/B \quad (3)$$

where:

$E$  = NaOH equivalent (in millilitres) to 1 mL of H<sub>2</sub>SO<sub>4</sub>,

$A$  = NaOH solution required (corrected), mL, and

<sup>6</sup> Annual Book of ASTM Standards, Vol 11.01.

<sup>6</sup> See *Paper and Paperboard—Characteristics, Nomenclature, and Significance of Tests*, ASTM STP 60-B, ASTM, 1963, pp. 59–61.