



SLOVENSKI STANDARD
SIST EN 1809:2014+A1:2016

01-maj-2016

Nadomešča:
SIST EN 1809:2014

Potapljaški pripomočki - Naprave za uravnavanje plovnosti - Funkcionalne in varnostne zahteve, preskusne metode

Diving equipment - Buoyancy compensators - Functional and safety requirements, test methods

Tauch-Zubehör - Tariermittel - Funktionelle und sicherheitstechnische Anforderungen, Prüfverfahren

Équipement de plongée - Bouée d'équilibrage - Exigences fonctionnelles et de sécurité, méthodes d'essai

<https://standards.iteh.ai/catalog/standards/sist/38623a08-ec6d-4fb2-87f5-0c2b0907883b/sist-en-1809-2014a1-2016>

Ta slovenski standard je istoveten z: EN 1809:2014+A1:2016

ICS:

97.220.40	Oprema za športe na prostem in vodne športe	Outdoor and water sports equipment
-----------	---	------------------------------------

SIST EN 1809:2014+A1:2016 **en,fr,de**

iTeh STANDARD PREVIEW
(standards.iteh.ai)

SIST EN 1809:2014+A1:2016

<https://standards.iteh.ai/catalog/standards/sist/38623a08-ec6d-4fb2-87f5-0c2b0907883b/sist-en-1809-2014a1-2016>

EUROPEAN STANDARD

EN 1809:2014+A1

NORME EUROPÉENNE

EUROPÄISCHE NORM

March 2016

ICS 97.220.40

Supersedes EN 1809:2014

English Version

Diving equipment - Buoyancy compensators - Functional and safety requirements, test methods

Équipement de plongée - Bouée d'équilibrage -
Exigences fonctionnelles et de sécurité, méthodes
d'essai

Tauch-Zubehör - Tariermittel - Funktionelle und
sicherheitstechnische Anforderungen, Prüfverfahren

This European Standard was approved by CEN on 14 May 2014 and includes Amendment 1 approved by CEN on 11 January 2016.

CEN members are bound to comply with the CEN/CENELEC Internal Regulations which stipulate the conditions for giving this European Standard the status of a national standard without any alteration. Up-to-date lists and bibliographical references concerning such national standards may be obtained on application to the CEN-CENELEC Management Centre or to any CEN member.

This European Standard exists in three official versions (English, French, German). A version in any other language made by translation under the responsibility of a CEN member into its own language and notified to the CEN-CENELEC Management Centre has the same status as the official versions.

CEN members are the national standards bodies of Austria, Belgium, Bulgaria, Croatia, Cyprus, Czech Republic, Denmark, Estonia, Finland, Former Yugoslav Republic of Macedonia, France, Germany, Greece, Hungary, Iceland, Ireland, Italy, Latvia, Lithuania, Luxembourg, Malta, Netherlands, Norway, Poland, Portugal, Romania, Slovakia, Slovenia, Spain, Sweden, Switzerland, Turkey and United Kingdom.



EUROPEAN COMMITTEE FOR STANDARDIZATION
COMITÉ EUROPÉEN DE NORMALISATION
EUROPÄISCHES KOMITEE FÜR NORMUNG

CEN-CENELEC Management Centre: Avenue Marnix 17, B-1000 Brussels

Contents	Page
European foreword.....	3
1 Scope	4
2 Normative references	4
3 Terms and definitions	4
4 Requirements	6
4.1 General	6
4.2 Mandatory features	6
4.3 Optional features	8
4.4 Long-term usability	9
4.5 Resistance to hydrostatic pressure	9
5 Test methods	9
5.1 General	9
5.2 Visual inspection	10
5.3 Wearing and environmental resistance tests	10
5.4 Hydrostatic pressure test	10
5.5 Buoyancy test	11
5.6 Inflator tests	11
5.7 Deflation device test	11
5.8 Pressure relief test	12
5.9 Drainage test	12
5.10 Test of oral inflation device	12
5.11 Test of auxiliary inflation devices	12
5.12 Flow capacity of medium pressure hose and connector	12
5.13 Practical performance test	14
6 Information supplied by the manufacturer	15
6.1 Marking	15
6.2 Instructions for use	16
Annex A (informative) Artificial sea water composition	17
Annex ZA (informative) Relationship between this European Standard and the Essential Requirements of Directive on personal protective equipment (PPE) 89/686/EEC	18
Bibliography	19

European foreword

This document (EN 1809:2014+A1:2016) has been prepared by Technical Committee CEN/TC 136 “Sports, playground and other recreational facilities and equipment”, the secretariat of which is held by DIN.

This European Standard shall be given the status of a national standard, either by publication of an identical text or by endorsement, at the latest by September 2016, and conflicting national standards shall be withdrawn at the latest by September 2016.

Attention is drawn to the possibility that some of the elements of this document may be the subject of patent rights. CEN [and/or CENELEC] shall not be held responsible for identifying any or all such patent rights.

This document includes Amendment 1 approved by CEN on 2016-01-11.

This document supersedes A1 EN 1809:2014 A1.

The start and finish of text introduced or altered by amendment is indicated in the text by tags A1 A1.

This document has been prepared under a mandate given to CEN by the European Commission and the European Free Trade Association and supports essential requirements of EU Directive on personal protective equipment (PPE) 89/686/EEC.

For relationship with EU Directive on personal protective equipment (PPE) 89/686/EEC, see informative Annex ZA, which is an integral part of this document.

In comparison with A1 ~~deleted text~~ A1 EN 1809:1997, the following significant changes A1 had A1 been made:

- a) updating of definitions;
- b) updating of test methods;
- c) introduction of pass/fail criteria for practical performance test;
- d) update of marking and instructions for use.

According to the CEN-CENELEC Internal Regulations, the national standards organizations of the following countries are bound to implement this European Standard: Austria, Belgium, Bulgaria, Croatia, Cyprus, Czech Republic, Denmark, Estonia, Finland, Former Yugoslav Republic of Macedonia, France, Germany, Greece, Hungary, Iceland, Ireland, Italy, Latvia, Lithuania, Luxembourg, Malta, Netherlands, Norway, Poland, Portugal, Romania, Slovakia, Slovenia, Spain, Sweden, Switzerland, Turkey and the United Kingdom.

EN 1809:2014+A1:2016 (E)**1 Scope**

This European Standard specifies functional, safety requirements and test methods applicable to inflatable type buoyancy compensating devices intended to provide divers with means for controlling buoyancy and if applicable, means for carrying the breathing equipment and/or carrying the weights.

This European Standard is not applicable to other kinds of personal equipment such as life preservers, personal flotation or rescue devices including combined buoyancy and rescue devices.

2 Normative references

The following documents, in whole or in part, are normatively referenced in this document and are indispensable for its application. For dated references, only the edition cited applies. For undated references, the latest edition of the referenced document (including any amendments) applies.

EN 250, *Respiratory equipment - Open-circuit self-contained compressed air diving apparatus - Requirements, testing and marking*

3 Terms and definitions

For the purposes of this document, the following terms and definitions apply.

3.1**buoyancy compensator****BC**

inflatable type device that provides the diver with a means for controlling buoyancy

iTeh STANDARD PREVIEW
(standards.iteh.ai)

3.2**buoyancy**

upward force exerted upon the immersed volume of a body

SIST EN 1809:2014+A1:2016

<https://standards.iteh.ai/en/standards/SIST-EN-1809-2014+A1-2016>

3.3**maximum buoyancy**

maximum upward force of a fully inflated BC

3.4**breathing apparatus**

system for providing the user with breathable gas

Note 1 to entry: The breathing apparatus may be, e.g. open circuit according to EN 250, re-breathers according to EN 14143 or umbilical supplied according to EN 15333-1 and EN 15333-2.

3.5**oral inflation device**

device that permits inflation of the BC by mouth

3.6**compressed gas inflation device**

device to inflate the BC with breathable gas mixture from the breathing apparatus or an independent source

3.7**deflation device**

device that permits deflation of the BC

Note 1 to entry: This device may be either manually or automatically operated.

3.8**pressure relief device**

device that automatically prevents over pressurisation of the BC

3.9**harness**

means by which the BC is secured to the user's body

3.10**carrying system**

carrying frame or holding device for breathing equipment with the possibility to mount the harness (if applicable)

3.11**auxiliary inflation device**

inflation device that is actuated to effect a rapid increase in buoyancy independent of the supply of breathable gas mixture from the breathing apparatus

iTeh STANDARD PREVIEW

3.12**cylinder**

container for breathable gas mixture under high pressure

[SIST EN 1809:2014+A1:2016](https://standards.iteh.ai/catalog/standards/sist/38623a08-ec6d-4fb2-87f5-0c2b0907883b/sist-en-1809-2014a1-2016)

3.13**breathable mixture**

breathing gas capable of supporting human life under appropriate diving conditions

<https://standards.iteh.ai/catalog/standards/sist/38623a08-ec6d-4fb2-87f5-0c2b0907883b/sist-en-1809-2014a1-2016>

3.14**rated pressure**

maximum rated pressure as indicated in the instructions for use of the BC as maximum working pressure for the inflation device

3.15**medium pressure**

pressure between the pressure reducer and the demand valve

3.16**bladder**

bag or bags containing the gas providing the buoyancy

EN 1809:2014+A1:2016 (E)**4 Requirements****4.1 General**

The BC shall not give evidence of any risk of injury of the diver, nor shall impair the operability of any of its components or that of a breathing apparatus.

The BC shall be equipped with several devices permitting respectively oral and compressed gas inflation, manual deflation, automatic pressure relief, drainage of entrapped water, and with a harness for securing it to the user's body.

Testing is in accordance with 5.2 and 5.13.

If the BC has more than one bladder, then each bladder, together with the associated inflation and deflation device, shall comply with the requirements of this standard.

4.2 Mandatory features**4.2.1 Oral inflation device**

Parts of the device that come into contact with the user's mouth shall be free of sharp edges and corners.

When tested in accordance with 5.13, the oral inflation device shall be assessed as readily accessible to the mouth and either hand in any stage of inflation of the BC. It shall be operable even when wearing protective gloves (three fingers, (6 ± 1) mm, double-lined).

The oral inflation device shall allow the BC to be easily inflated by mouth when tested in accordance with 5.13.

The oral inflation device shall withstand a pulling force of 150 N for (10 ± 1) s without damage and remain functional.

Testing is in accordance with 5.10.

4.2.2 Compressed gas inflation device

This comprises a medium pressure hose and a valve that shall be actuated subsequent to one positive, manual operation such as pressing a button, or by an automatic control system.

Gas supply shall be capable of simple isolation or able to be disconnected between the hose and the inflation device by a quick connect coupling. If a quick connection coupling is fitted, the preferred configuration for the male part of the inflation device is as shown in Figure 1, where only the relevant dimensions are specified. If the configuration of the connection used is different from the preferred one, it shall not be possible to connect the female connection to the preferred male connector. It shall be possible to isolate or disconnect the gas supply with either hand when wearing protective gloves (three fingers, $6 \text{ mm} \pm 1 \text{ mm}$, double-lined).

Testing is in accordance with 5.13.

Dimensions in millimetres

A1

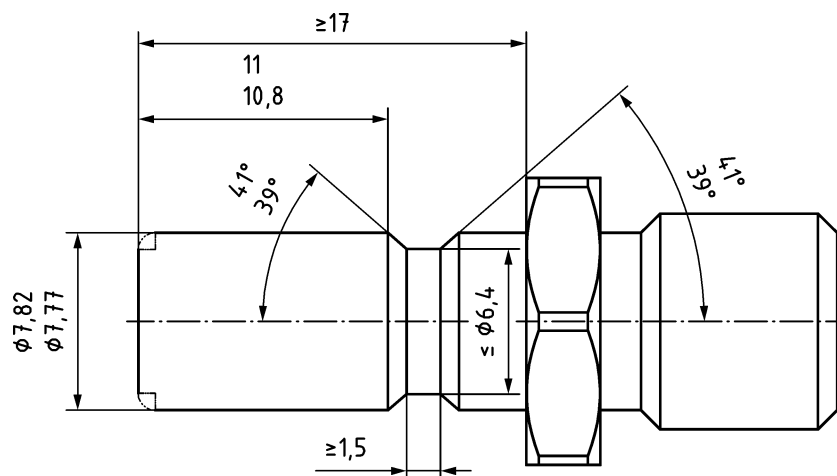

A1

Figure 1 — Quick release male connector

The inflation device shall remain functional with a medium pressure twice its rated working pressure or at least (20 ± 1) bar.

The inflation device shall withstand a medium pressure of at least 30 bar for 60 s.

Testing is in accordance with 5.6.2.

The medium pressure hoses assembly shall comply with the appropriate requirements of EN 250.

If the medium pressure hose is provided with a quick connect coupling, the hose connected to the male part of the quick connect coupling shall have a minimum air flow of 250 l/min STPD, when connected to a constant 10 bar supply.

Testing is in accordance with 5.12.

The maximum buoyancy, determined in accordance with 5.5, shall be built up at a rate greater than 15 N/s at a minimum medium pressure according to manufacturer's instructions and in no case higher than 6 bar.

Testing is in accordance with 5.6.1.

4.2.3 Deflation device

4.2.3.1 The BC shall have at least one manually operated deflation device.

Testing is in accordance with 5.13.

4.2.3.2 If deflation devices are manually operated, they shall be activated by one positive manual operation, such as pressing a button or pulling a cord. They shall be operable even when wearing protective gloves (three fingers, (6 ± 1) mm, double-lined). At least one device shall be readily accessible at any stage of operation of the BC.

Testing is in accordance with 5.13.

4.2.3.3 The flow capacity of at least one deflation device shall be greater than the maximum flow that may be achieved by any individual inflation device.

EN 1809:2014+A1:2016 (E)

Testing is in accordance with 5.7.1.

4.2.3.4 The deflation device shall allow a loss of buoyancy, at a rate greater than 20 N/s.

Testing is in accordance with 5.7.2.

4.2.3.5 If the manual deflation device is operated by means of a pulling system, it shall withstand a tensile force of 150 N for 10 s and remain functional when tested in accordance with 5.7.3.

4.2.4 Pressure relief device

The pressure relief device shall prevent damage to the BC through over-pressurization.

When tested in accordance with 5.8, the pressure inside the BC shall not exceed 50 % of its burst pressure.

The BC shall have a minimum burst pressure of 0,5 bar above atmospheric pressure.

4.2.5 Means for drainage of entrapped water

When tested in accordance with 5.9, the weight of entrapped water shall be less than 2 % of the maximum buoyancy of the BC and in any case not more than 0,8 kg.

4.2.6 Harness

This feature, which incorporates strapping or other means of attachment, shall perform its function of securing the BC to the body taking into account different body sizes. The means of attachment shall not interfere with the removal of the user's ballast weights when the BC is donned in accordance with the manufacturer's instructions.

Testing is in accordance with 5.13.

4.3 Optional features

[SIST EN 1809:2014+A1:2016
https://standards.iteh.ai/catalog/standards/sist/38623a08-ec6d-4fb2-87f5-0c2b0907883b/sist-en-1809-2014a1-2016](https://standards.iteh.ai/catalog/standards/sist/38623a08-ec6d-4fb2-87f5-0c2b0907883b/sist-en-1809-2014a1-2016)

4.3.1 Influence on mandatory features

If the BC is equipped with optional features, these shall be assessed as not compromising the effectiveness of the mandatory features during the practical performance test in accordance with 5.13.

4.3.2 Carrying system

If a breathing apparatus is attached to the BC, it shall not become loose, in or out of water, when tested in accordance with 5.13.

4.3.3 Body harness

If the BC is used as the body harness of a carrying system of a breathing apparatus, it shall comply with the appropriate requirements of EN 250.

4.3.4 Auxiliary breathing system

If the BC is provided with an open circuit demand auxiliary breathing system, the auxiliary breathing system shall comply with the appropriate requirements of EN 250.

The system shall use a different quick connector to that specified in 4.2.2.

4.3.5 Auxiliary inflation devices

4.3.5.1 If the BC is equipped with an auxiliary inflation device, this shall comply with the requirements of 4.3.5.2 to 4.3.5.5.

4.3.5.2 The auxiliary inflation device shall contain a breathable mixture.

4.3.5.3 The device actuating the release of gas shall be accessible and operable even when wearing protective gloves (three fingers, (6 ± 1) mm, double-lined).

Testing is in accordance with 5.13.

4.3.5.4 At atmospheric pressure, the BC shall inflate to its maximum buoyancy given in 5.5 at a rate greater than 50 N/s after operating the auxiliary device when tested in accordance with 5.11.

4.3.5.5 The auxiliary inflation device shall be fixed such that it cannot be loosened or actuated unintentionally, when tested in accordance with 5.13.

4.3.6 Ballasting integrated device

The ballast integrated device(s) shall not be detached unintentionally.

The part of the ballast that is proposed by the manufacturer as detachable in an emergency situation shall be easily accessible and quickly detached when wearing protective gloves (three fingers, (6 ± 1) mm, double-lined) at all inflation states of the bladder(s).

Testing is in accordance with 5.2 and 5.13.

4.4 Long-term usability

After submission to the high temperature, low temperature and sea water conditioning defined in 5.3.2 to 5.3.4 and then tested in accordance with 5.6, the BC sample shall remain in a serviceable condition; show no signs of physical damage such as tears, loose seams, broken or distorted hardware. The cylinder(s) (if any) shall show no dislocation as to impair the operability of the breathing apparatus.

Testing is in accordance with 5.2.

After submission to the wearing resistance test defined in 5.3.5 and the subsequent check of the mechanical inflation device for leakage, the maximum allowed leakage of air into the body of the BC shall be 0,5 l/min at room temperature.

On immersion, there shall be no constant bubbling indicating outside leakage.

4.5 Resistance to hydrostatic pressure

After submission to the hydrostatic pressure test defined in 5.4, the BC shall remain functional. The ingress of water in the BC during the test shall not exceed 1 l.

5 Test methods

5.1 General

5.1.1 Testing condition

If the same model of BC is in different sizes, one sample of each size shall be submitted to visual inspection and to buoyancy test in accordance with 5.2 and 5.5.

All buoyancy tests shall be conducted in fresh water, all other tests can be done in fresh or in sea water.

Except as otherwise indicated, the waist belt and shoulder belt shall be securely closed during testing.

Submission to all of the following tests shall occur after the BC sample has been tested in accordance with 5.3.