



Designation: D1439 – 03(Reapproved 2008)<sup>ε1</sup>

## Standard Test Methods for Sodium Carboxymethylcellulose<sup>1</sup>

This standard is issued under the fixed designation D1439; the number immediately following the designation indicates the year of original adoption or, in the case of revision, the year of last revision. A number in parentheses indicates the year of last reapproval. A superscript epsilon ( $\epsilon$ ) indicates an editorial change since the last revision or reapproval.

<sup>ε1</sup> NOTE—Editorial changes were made in Sections 11, 12, 15.5, and 31.1 in June 2008.

### 1. Scope

1.1 These test methods cover the testing of sodium carboxymethylcellulose.

1.2 The test procedures appear in the following order:

	Sections
Moisture	4 – 9
Degree of Etherification:	
Test Method A—Acid Wash	10 – 17
Test Method B—Nonaqueous Titration	10, 12, 18 – 23
Viscosity	24 – 30
Purity	31 – 38
Sodium Glycolate	39 – 47
Sodium Chloride	48 – 55
Density	56 – 62

1.3 The values stated in SI units are to be regarded as the standard. The values given in parentheses are for information only.

1.4 *This standard does not purport to address all of the safety concerns, if any, associated with its use. It is the responsibility of the user of this standard to establish appropriate safety and health practices and determine the applicability of regulatory limitations prior to use.* For specific hazard statements, see 15.1 and 20.

### 2. Referenced Documents

2.1 *ASTM Standards*:<sup>2</sup>

D1347 Test Methods for Methylcellulose (Withdrawn 2003)<sup>3</sup>

E1 Specification for ASTM Liquid-in-Glass Thermometers

### 3. Purity of Reagents

3.1 Reagent grade chemicals shall be used in all tests. Unless otherwise indicated, it is intended that all reagents shall

<sup>1</sup> These test methods are under the jurisdiction of ASTM Committee D01 on Paint and Related Coatings, Materials, and Applications and are the direct responsibility of Subcommittee D01.36 on Cellulose and Cellulose Derivatives.

Current edition approved June 1, 2008. Published June 2008. Originally approved in 1956. Last previous edition approved in 2003 as D1439 – 03. DOI: 10.1520/D1439-03R08E01.

<sup>2</sup> For referenced ASTM standards, visit the ASTM website, www.astm.org, or contact ASTM Customer Service at service@astm.org. For *Annual Book of ASTM Standards* volume information, refer to the standard's Document Summary page on the ASTM website.

<sup>3</sup> The last approved version of this historical standard is referenced on www.astm.org.

conform to the specifications of the Committee on Analytical Reagents of the American Chemical Society<sup>4</sup>, where such specifications are available. Other grades may be used, provided it is first ascertained that the reagent is of sufficiently high purity to permit its use without lessening the accuracy of the determination.

3.2 Unless otherwise indicated, references to water shall be understood to mean distilled water.

## MOISTURE

### 4. Scope

4.1 This test method covers the determination of the volatile content of sodium carboxymethylcellulose.

4.2 The results of this test are used for calculating the total solids in the sample; and, by common usage, all materials volatile at this test temperature are designated as moisture.

### 5. Significance and Use

5.1 Moisture analysis (along with purity) is used to calculate the amount of active polymer in the material and must be considered when determining the amount of sodium carboxymethylcellulose to use in various formulations.

### 6. Apparatus

6.1 *Oven*—Gravity convection oven, capable of maintaining a temperature of  $105 \pm 3^\circ\text{C}$ .

6.2 *Weighing Bottles*, low-form, 50-mm inside diameter by 30-mm height, or equivalent.

6.3 *Analytical Balance*.

### 7. Procedure

7.1 Weigh 3 to 5 g of the sample to the nearest 0.001 g in a tared and covered weighing bottle.

<sup>4</sup> *Reagent Chemicals, American Chemical Society Specifications*, American Chemical Society, Washington, DC. For suggestions on the testing of reagents not listed by the American Chemical Society, see *Analar Standards for Laboratory Chemicals*, BDH Ltd., Poole, Dorset, U.K., and the *United States Pharmacopeia and National Formulary*, U.S. Pharmacopeial Convention, Inc. (USPC), Rockville, MD.

7.2 Place the bottle in an oven at 105°C for 2 h with the cover removed. Cool the bottle in a desiccator, replace the cover, and weigh.

7.3 Replace the sample in the oven for 30 min, cool, and reweigh.

7.4 Continue this procedure to a mass loss of not more than 5 mg for 30 min drying time.

## 8. Calculation

8.1 Calculate the percent moisture,  $M$ , as follows:

$$M = (A/B) \times 100 \quad (1)$$

where:

$A$  = mass loss on heating, g, and

$B$  = sample used, g.

## 9. Precision and Bias

9.1 *Precision*—Statistical analysis of interlaboratory reproducibility test results on samples containing 2 to 10 % moisture indicates a precision of  $\pm 0.2$  % absolute at the 95 % confidence level.

9.2 *Bias*—No justifiable statement can be made on the bias of the procedure for measuring moisture because no suitable reference material exists.

## DEGREE OF ETHERIFICATION

### 10. Scope

10.1 These test methods cover the determination of the degree of etherification (D.E.) of sodium carboxymethylcellulose.

10.2 Two test methods are included as follows:

10.2.1 *Test Method A (Acid Wash)*, for crude grades of sodium carboxymethylcellulose with degrees of etherification up to 0.85. Above 0.85 degree of etherification, slightly low results may be obtained.

10.2.2 *Test Method B (Nonaqueous Titration)*, for purified grades of sodium carboxymethylcellulose of all degrees of etherification. It is not applicable to the crude grades.

### 11. Significance and Use

11.1 These test methods determine the amount of substituent groups added to the cellulose backbone. The level can greatly affect solution properties, rheology, viscosity, hygroscopicity, salt tolerance, and many other properties of the polymer.

*Test Method A—Acid Wash*

### 12. Summary of Test Method

12.1 The water-soluble sodium carboxymethylcellulose is converted to the insoluble acid form, purified by washing, dried, and then a weighed sample is reconverted to the sodium salt with a measured excess of sodium hydroxide.

### 13. Apparatus

13.1 *Stirrer*, air-driven.

13.2 *Buchner Funnel*, 75-mm, fitted with a 70-mm fine-texture, heavy-duty filter paper. A 60-mm medium-porosity, fritted glass funnel may also be used.

13.3 *Drying Oven*, maintained at 105°C.

## 14. Reagents

14.1 *Diphenylamine Reagent*—Dissolve 0.5 g of diphenylamine in 120 mL of sulfuric acid ( $H_2SO_4$ , 9 + 2). The reagent should be essentially water-white. It will give a deep blue coloration with traces of nitrate or other oxidizing agents.

14.2 *Ethyl Alcohol (95 volume %)*—Denatured ethyl alcohol conforming to either Formula 2B, 3A, or 30 of the U. S. Bureau of Internal Revenue.

14.3 *Ethyl Alcohol (80 % by volume)*—Dilute 840 mL of Formula 2B, 3A, or 30 denatured alcohol to 1 L with water.

14.4 *Hydrochloric Acid, Standard* (HCl, 0.3 to 0.5  $N$ ).

14.5 *Methanol*, anhydrous.

14.6 *Nitric Acid (sp gr 1.42)*—Concentrated nitric acid ( $HNO_3$ ).

14.7 *Sodium Hydroxide, Standard Solution (0.3 to 0.5  $N$ )*—Prepare and standardize a 0.3 to 0.5  $N$  solution of sodium hydroxide (NaOH).

14.8 *Sulfuric Acid (9 + 2)*—Carefully mix 9 volumes  $H_2SO_4$  with 2 volumes of water.

## 15. Procedure

15.1 Weigh approximately 4 g of the sample into a 250-mL beaker and add 75 mL of ethyl alcohol (95 %). Stir the mixture with an air-driven stirrer until a good slurry is obtained. Add 5 mL of  $HNO_3$ , while agitating, and continue agitation for 1 to 2 min. Heat the slurry and boil for 5 min. (**Warning**—Exercise care to avoid fire.) Remove the heat and continue agitation for 10 to 15 min.

15.2 Decant the supernatant liquid through the filter and transfer the precipitate to the filter with 50 to 100 mL of ethyl alcohol (95 %). Wash the precipitate with ethyl alcohol (80 %) that has been heated to 60°C, until all of the acid has been removed.

15.3 Test for the removal of acid and salts (ash) by mixing a drop of the acid carboxymethylcellulose slurry from the filter with a drop of diphenylamine reagent on a white spot plate. A blue color indicates the presence of nitrate and the necessity for further washing. If the first drop of reagent does not produce a blue color, further drops should be added until an excess of reagent is known to be present, noting the color after each drop. Four to six washings will usually suffice to give a negative test for nitrate.

15.4 Finally, wash the precipitate with a small amount of anhydrous methanol and draw air through it until the alcohol is completely removed. Transfer the precipitate to a glass or aluminum weighing dish provided with a cover. Heat the uncovered dish on a steam bath until the odor of alcohol can no longer be detected (in order to avoid fires due to methanol fumes in the oven), then dry the dish and contents, uncovered

for 3 h at 105°C. Place the cover on the dish and cool to room temperature in a desiccator.

15.5 The sulfate ash content of the sample at this point should be less than 0.5 % when determined on 0.5 g of the sample by the procedure given in the Ash as Sulfate section of Test Methods **D1347**. If the ash content is greater than 0.5 %, rewash the sample with ethyl alcohol (80 %). If necessary, repeat the procedure described in **15.1 – 15.4**.

15.6 Weigh, to the nearest 0.01 g, about 1 to 1.5 g of the dried acid carboxymethylcellulose (depending on the normality of the acid and base to be used) into a 500-mL Erlenmeyer flask. Add 100 mL of water and 25.00 mL of 0.3 to 0.5 *N* NaOH solution, while stirring. Heat the solution to boiling, and boil for 15 to 30 min.

15.7 Titrate the excess NaOH, while the solution is hot, with the 0.3 to 0.5 *N* HCl to a phenolphthalein end point.

## 16. Calculation

16.1 Calculate the degree of etherification, *G*, as follows:

$$A = (BC - DE)/F \quad (2)$$

$$G = 0.162A/(1 - 0.0584A) \quad (3)$$

where:

- A* = milliequivalents of acid consumed per gram of sample,
- B* = NaOH solution added, mL,
- C* = normality of the NaOH solution,
- D* = HCl required for titration of the excess NaOH, mL,
- E* = normality of the HCl,
- F* = acid carboxymethylcellulose used, g,
- 162 = gram molecular mass of the anhydroglucose unit of cellulose, and
- 58 = net increase in molecular mass of anhydroglucose unit for each carboxymethyl group substituted.

## 17. Precision and Bias

17.1 *Precision*—Statistical analysis of intralaboratory (repeatability) test results indicates a precision of ±0.04 D.E. units at the 95 % confidence level.

17.2 *Bias*—No justifiable statement can be made on the bias of the procedure for measuring degree of etherification because no suitable reference material exists.

### *Test Method B—Nonaqueous Titration*

## 18. Summary of Test Methods

18.1 This measurement is based upon a nonaqueous acid-base titration. The sample is refluxed with glacial acetic acid, and the resulting sodium acetate is titrated with a standard solution of perchloric acid in dioxane, to a potentiometric end point. Impurities containing alkaline sodium will also be titrated under these conditions. Sodium chloride does not interfere.

## 19. Apparatus

19.1 *pH Meter*, equipped with a standard glass electrode and a calomel electrode modified as follows:

19.1.1 Discard the aqueous potassium chloride solution, then rinse and fill with the calomel electrode solution as described in **20.2**.

19.1.2 Add a few crystals of potassium chloride and silver chloride or silver oxide to the electrode.

19.2 *Buret*, micro, 10-mL capacity.

## 20. Reagents

20.1 *Acetic Acid*, glacial.

20.2 *Calomel Electrode Solution*—Add 2 g of potassium chloride (KCl) and 2 g of silver chloride (AgCl) or silver oxide (Ag<sub>2</sub>O) to 100 mL of methanol and shake thoroughly to saturate. Use the supernatant liquid.

20.3 *1,4-Dioxane*.

20.4 *Perchloric Acid* (0.1 *N*)—Add 9 mL of concentrated perchloric acid (HClO<sub>4</sub>, 70 % to 1 L of dioxane, with stirring (**Warning**—The solution of perchloric acid in dioxane should never be heated or allowed to evaporate.). Store in an amber glass bottle. Any slight discoloration that appears on standing may be disregarded.

20.4.1 Standardize the solution as follows: Dry potassium acid phthalate for 2 h at 120°C. Weigh 2.5 g to the nearest 0.0001 g into a 250-mL volumetric flask. Add glacial acetic acid, shake to dissolve, and then make up to volume and mix thoroughly. Pipet 10 mL into a 100-mL beaker and add 50 mL of acetic acid. Place on a magnetic stirrer and insert the electrodes of the pH meter. Add nearly the required amount of HClO<sub>4</sub> from a buret, then decrease the increments to 0.05 mL as the end point is approached. Record the millilitres of titrant versus millivolts, and continue the titration a few millilitres beyond the end point. Plot the titration curve and read the volume of titrant at the inflection point. Calculate the normality, *N*, as follows:

$$N = (A \times 10 \times 1000)/(B \times 204.22 \times 250) \quad (4)$$

where:

- A* = potassium acid phthalate used, g,
- B* = HClO<sub>4</sub> added, mL,
- 204.22 = gram molecular mass of potassium acid phthalate,
- 10 = potassium acid phthalate solution added, mL, and
- 250 = glacial acetic acid used to dissolve potassium acid phthalate, mL.

20.5 *Potassium Acid Phthalate*, primary standard, National Institute of Standards and Technology Standard Sample No. 84.

## 21. Procedure

21.1 Weigh 0.2 g of the sample, to the nearest 0.0001 g, into a 250-mL Erlenmeyer flask with ground-glass joint. Add 75 mL of acetic acid, connect to a water-cooled condenser, and reflux gently on a hot plate for 2 h.

21.2 Cool, and transfer the solution to a 250-mL beaker with the aid of 50 mL of acetic acid. Place on the magnetic stirrer and titrate to a potentiometric end point with 0.1 *N* HClO<sub>4</sub> in accordance with **20.4**.

## 22. Calculation

22.1 Calculate the degree of etherification,  $H$ , as follows (Note 1):

$$M = (AN \times 100) / (G \times (100 - B)) \quad (5)$$

$$H = 0.162 M / (1.000 - (0.080 M)) \quad (6)$$

where:

- $M$  = milliequivalents of acid consumed per gram of sample,
- $A$  =  $\text{HClO}_4$  added, mL,
- $N$  = normality of  $\text{HClO}_4$ ,
- $G$  = sample used, g,
- $B$  = percent moisture, determined on a separate sample, in accordance with Sections 4 – 7,
- 162 = gram molecular mass of an anhydroglucose unit of cellulose, and
- 80 = net increase in molecular mass of an anhydroglucose unit for each sodium carboxymethyl group added.

NOTE 1—The result calculated in accordance with Section 18 includes the alkaline sodium from sodium glycolate; however, if the latter is less than 0.5 %, the interference is negligible.

## 23. Precision and Bias

23.1 *Precision*—Statistical analysis of interlaboratory test results indicates the precision of this test method as shown below:

Approximate D.E. Level	Precision, D.E. Units (95 % Confidence Level)
0.40	±0.010
0.80	±0.012
1.35	±0.038

23.2 *Bias*—No justifiable statement can be made on the bias of the procedure for measuring degree of etherification because no suitable reference material exists.

## VISCOSITY

### 24. Scope

24.1 This is an arbitrary test method for determining the viscosity of aqueous solutions of sodium carboxymethylcellulose in the viscosity range from 10 to 10 000 cP at 25°C.

24.2 The concentration to be used for the test should be agreed upon between the purchaser and the seller. It should be such that the viscosity of the solution will fall within the range of this test.

24.3 The results for the viscosity of sodium carboxymethylcellulose by this test method will not necessarily check with results from other types of instruments used for viscosity measurements.

24.4 The determinations are run on a calculated dry basis; that is, the amount of sodium carboxymethylcellulose required for the desired concentration on a dry basis is calculated from the known moisture content.

24.5 This test method is intended for referee purposes. The Brookfield spindles and speeds given in Table 1 are recommended for this purpose, but slight derivations from the table may occasionally be found convenient for individual application.

TABLE 1 Viscometer Spindles Required for Given Speeds

Viscosity Range, cP	Spindle No.	Speed, rpm	Scale	Factor
10 to 100	1	60	100	1
100 to 200	1	30	100	2
200 to 1000	2	30	100	10
1000 to 4000	3	30	100	40
4000 to 10000	4	30	100	200

## 25. Significance and Use

25.1 This test method determines the relative ability of the polymer to thicken water. This is the primary function of sodium carboxymethylcellulose.

## 26. Apparatus

26.1 *Viscometer*, Brookfield type.

26.2 *Container*—Glass jar, approximately 64-mm (2½-in.) in diameter and 152 mm (6 in.) deep, unconstricted at the top, capacity 340 g (12 oz).

26.3 *Analytical Balance*.

26.4 *Mechanical Stirrer*—Stirrer constructed of stainless steel (Fig. 1) attached to a variable speed motor capable of operating at 900 ± 100 rpm under varying load conditions.

26.5 *Water Bath*, constant-temperature, set at 25°C and capable of maintaining that temperature within ±0.2°C.

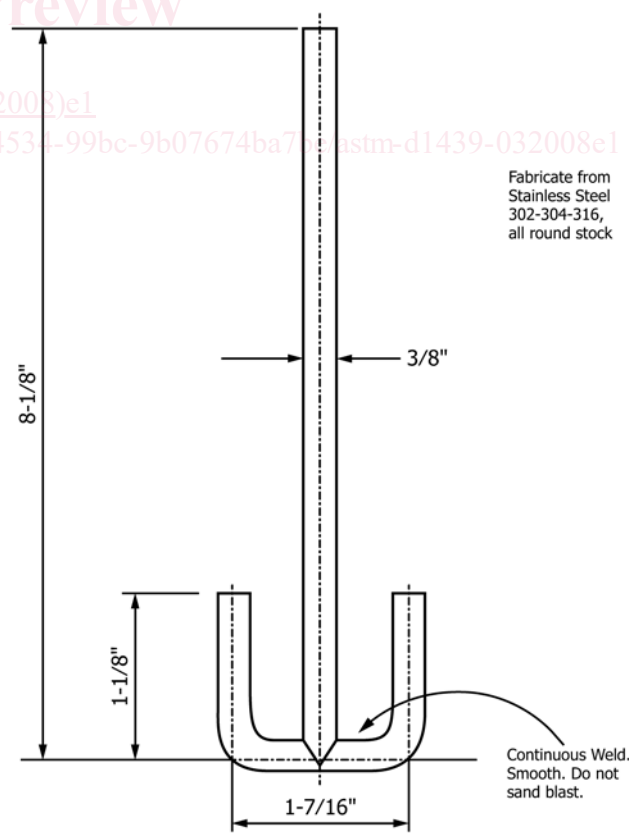

FIG. 1 Stirrer