

---

# International Standard



# 1609

---

INTERNATIONAL ORGANIZATION FOR STANDARDIZATION • МЕЖДУНАРОДНАЯ ОРГАНИЗАЦИЯ ПО СТАНДАРТИЗАЦИИ • ORGANISATION INTERNATIONALE DE NORMALISATION

---

## Vacuum technology — Flange dimensions

*Technique du vide — Dimensions des brides*

First edition — 1986-03-15

**iTeh STANDARD PREVIEW**  
**(standards.iteh.ai)**

[ISO 1609:1986](https://standards.iteh.ai/catalog/standards/sist/79a915be-59ce-4010-946c-98087a6171c2/iso-1609-1986)

<https://standards.iteh.ai/catalog/standards/sist/79a915be-59ce-4010-946c-98087a6171c2/iso-1609-1986>

---

UDC 621.643.412-168

Ref. No. ISO 1609-1986 (E)

Descriptors : vacuum technology, flanges, flange collars, dimensions.

## Foreword

ISO (the International Organization for Standardization) is a worldwide federation of national standards bodies (ISO member bodies). The work of preparing International Standards is normally carried out through ISO technical committees. Each member body interested in a subject for which a technical committee has been established has the right to be represented on that committee. International organizations, governmental and non-governmental, in liaison with ISO, also take part in the work.

Draft International Standards adopted by the technical committees are circulated to the member bodies for approval before their acceptance as International Standards by the ISO Council. They are approved in accordance with ISO procedures requiring at least 75 % approval by the member bodies voting.

International Standard ISO 1609 was prepared by Technical Committee ISO/TC 112, *Vacuum technology*.

Users should note that all International Standards undergo revision from time to time and that any reference made herein to any other International Standard implies its latest edition, unless otherwise stated.

# Vacuum technology — Flange dimensions

## 1 Scope and field of application

This International Standard specifies the dimensions for flanges and collars used in vacuum technology.

The dimensions ensure interchangeability between bolted, clamped and rotatable flanges,

a) whether the assembly be homogeneous (for example, bolted flanges or clamped flanges) or heterogeneous (for example, bolted flanges assembled with clamped flanges either by means of bolts or clamps or by means of bolts and rotatable flanges);

b) whether the sealing rings used with the flanges be elastomer O-rings or metal sealing rings, provided that they are compatible with the linear sealing loads given in annex A.

## 2 References

ISO 3, *Preferred numbers — Series of preferred numbers.*

ISO 273, *Fasteners — Clearance holes for bolts and screws.*

ISO 286, *ISO system of limits and fits.*<sup>1)</sup>

ISO 887, *Plain washers for metric bolts, screws and nuts — General plan.*

ISO 1127, *Stainless steel tubes — Dimensions, tolerances and conventional masses per unit length.*

ISO 2861/1, *Vacuum technology — Quick-release couplings — Dimensions — Part 1: Clamped type.*

ISO 4200, *Plain end steel tubes, welded and seamless — General tables of dimensions and masses per unit length.*

## 3 Dimensions

### 3.1 General

3.1.1 The dimensions of the flanges or collars shall conform to those specified in tables 1, 2 and 3 and shown in figures 1, 2 and 3. These dimensions are for finished products and do not include allowance for machining. Flanges or collars with nominal bores of 10 to 40 inclusive, given in tables 1, 2 and 3, accept the corresponding quick-release couplings specified in ISO 2861/1. Relevant dimensions and tolerances are specified in annex B.

3.1.2 The selection of materials shall be compatible with the requirements for flanges and collars used in vacuum technology and with the dimensions given in tables 1, 2 and 3.

3.1.3 In order to ensure the interchangeability of vacuum components, the flanges shall be aligned so that the bolt holes are spaced equidistantly about and off the symmetrical plane of the component.

1) At present at the stage of draft. (Revision of ISO/R 286-1962.)

**3.2 Nominal bore**

**3.2.1** The tables provide a series of values of nominal bores intended to identify the flanges or collars.

**3.2.2** These values follow the progression of the R10 series of preferred numbers (see ISO 3) from which only the term 12,5 has been eliminated.

**3.2.3** The values of nominal bore belonging to the R5 series of preferred numbers (see ISO 3) are as follows: 10, 16, 25, 40, 63, 100, 160, 250, 400, 630 and 1 000. They correspond to values intended to permit, in the long term, the adoption of a reduced series of nominal bores.

**3.2.4** The nominal bores 63 and 160 given in tables 1, 2 and 3 correspond to practical diameters of 70 mm (or 65 mm) and 153 mm respectively.

**3.3 Diameter of bolt holes, C**

The values for the diameter of bolt holes, *C*, are derived from the bolt diameters, *D*, in accordance with ISO 273 — medium series.

**3.4 Bolt diameter, D**

For a flange of given nominal bore, the bolt diameter, *D*, is the same for both bolted and rotatable flanges.

**3.5 Mating face**

**3.5.1 Definition**

The mating face of the flange is the area in the form of a ring, the surface finish and the flatness of which make the sealing of the joint possible.

**3.5.2 Limits**

The minimum mating face is defined by diameter *E* in table 1 and *S* in table 2, and by diameter *F* in tables 1 and 2.

**3.5.3 Profile**

The flange sealing face shall be flat and no part of the flange shall project in relation to this plane.

**3.6 Width of the collar onto which the clamp hooks, G**

The value for the width depends on the system of clamps used and should not be greater than 2,5 mm.

**3.7 Outside diameter of bolted and rotatable flanges, H**

The dimensions given for the outside diameter are compatible with the requirement that the bolt washers (ISO 887 — small series) shall not project beyond the outer circumference of the flange.

**3.8 Number of bolt holes, n**

The linear sealing loads tabulated in annex A for a given bolt stress are derived from the values of the number of bolt holes, *n*.

**3.9 Inner diameter for the contact area of clamps, U**

So as to take into account the diversity of the clamping systems which may be used, for example on collars with welding necks, the maximum inner diameter of the annulus reserved for contact with the clamps is defined by diameter *U*.

iTeh STANDARD PREVIEW  
(standards.iteh.ai)

ISO 1609-1986  
<https://standards.iteh.ai/catalog/standards/sist/79a915be-59ce-4010-946c-98087a6171c2/iso-1609-1986>

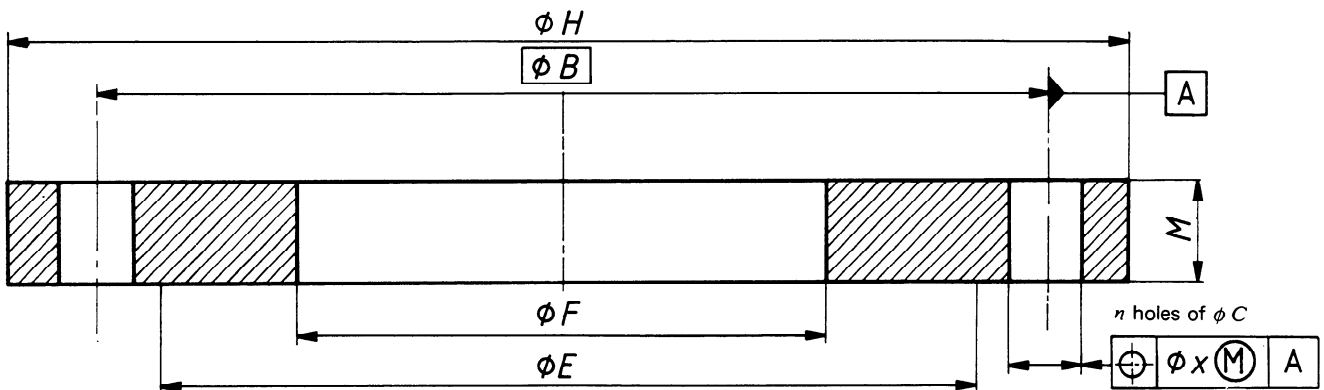

Figure 1 – Bolted flange

Table 1 – Dimensions of bolted flanges

Dimensions in millimetres

Nominal bore*	B	C H13	e	Bolts		E**	F**	H	M js16
				D	n				
10	40	6,6	0,6	6	4	30	12,2	55	8
16	45	6,6	0,6	6	4	35	17,2	60	8
20	50	6,6	0,6	6	4	40	22,2	65	8
25	55	6,6	0,6	6	4	45	26,2	70	8
32	70	9	1	8	4	55	34,2	90	8
40	80	9	1	8	4	65	41,2	100	12
50	90	9	1	8	4	75	52,2	110	12
63	110	9	1	8	4	95	70	130	12
80	125	9	1	8	8	110	83	145	12
100	145	9	1	8	8	130	102	165	12
125	175	11	1	10	8	155	127	200	16
160	200	11	1	10	8	180	153	225	16
200	260	11	1	10	12	240	213	285	16
250	310	11	1	10	12	290	261	335	16
320	395	14	2	12	12	370	318	425	20
400	480	14	2	12	16	450	400	510	20
500	580	14	2	12	16	550	501	610	20
630	720	14	2	12	20	690	651	750	24
800	890	14	2	12	24	860	800	920	24
1 000	1 090	14	2	12	32	1 060	1 000	1 120	24

\* See 3.2. It should be noted that the nominal bores recommended above 1 000 are: 1 250, 1 600, 2 000 and 2 500.

\*\* See 3.5.2.

Dimensions in millimetres

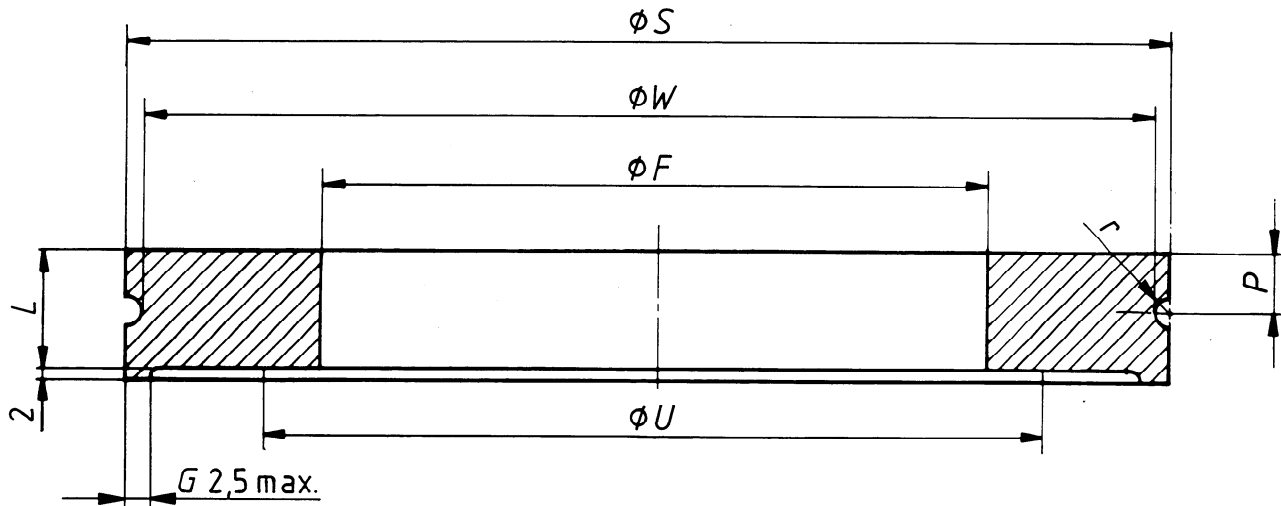

Figure 2 – Collar for clamped or rotatable flanges

Table 2 – Dimensions of collars for clamped or rotatable flanges

Dimensions in millimetres

Nominal bore*	F**	L js16	P H14	r B10	S** h11	U***	W h11
10	12,2	6	3	1	30	15	28
16	17,2	6	3	1	35	20	33
20	22,2	6	3	1	40	25	38
25	26,2	6	3	1	45	30	43
32	34,2	6	3	1	55	40	53
40	41,2	10	5	1,5	65	50	62
50	52,2	10	5	1,5	75	60	72
63	70	10	5	1,5	95	80	92
80	83	10	5	1,5	110	95	107
100	102	10	5	1,5	130	115	127
125	127	10	5	2,5	155	140	150
160	153	10	5	2,5	180	165	175
200	213	10	5	2,5	240	225	235
250	261	10	5	2,5	290	275	285
320	318	15	7,5	2,5	370	355	365
400	400	15	7,5	4	450	435	442
500	501	15	7,5	4	550	535	542
630	651	20	10	5	690	660	680

\* See 3.2. It should be noted that the nominal bores recommended above 630 are: 800, 1 000, 1 250, 1 600, 2 000 and 2 500.

\*\* See 3.5.2.

\*\*\* See 3.9.

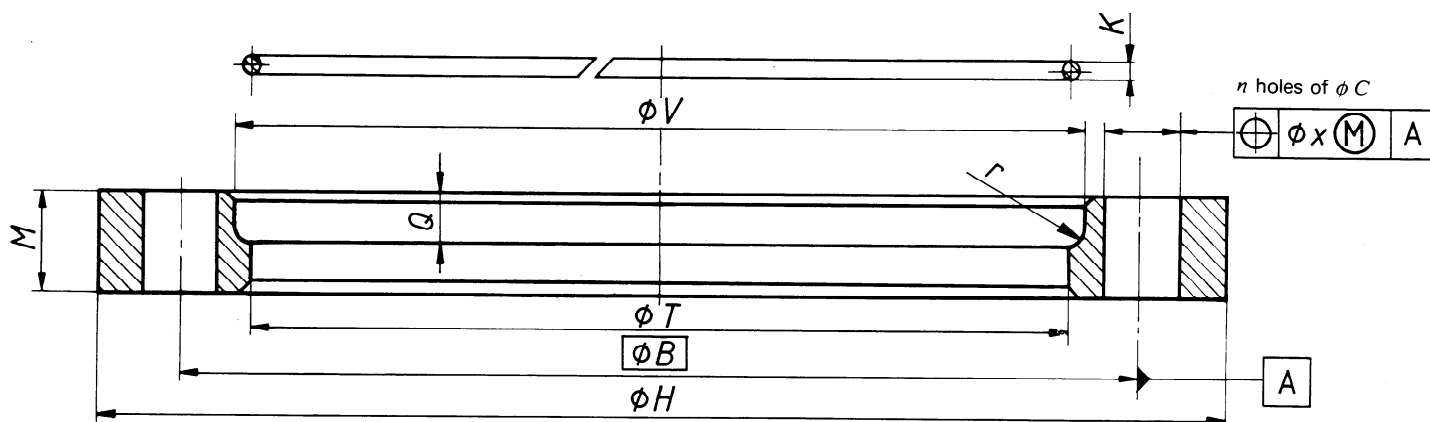

NOTE — The diameter of the retaining ring shall be compatible with dimension V.

Figure 3 — Rotatable flange with retaining ring

Table 3 — Dimensions of rotatable flanges with retaining rings

Dimensions in millimetres

Nominal bore*	B	C H13	x	Bolts		H	K**	M js16	Q***	T H11	V H14	r B10
				D	n							
10	40	6,6	0,6	6	4	55	2	8	3	30,1	32,1	1
16	45	6,6	0,6	6	4	60	2	8	3	35,1	37,1	1
20	50	6,6	0,6	6	4	65	2	8	3	40,1	42,1	1
	55	6,6	0,6	6	4	70	2	8	3	45,1	47,1	1
25	60	6,6	0,6	6	4	75	2	8	3	50,1	52,1	1
	65	6,6	0,6	6	4	80	2	8	3	55,5	57,5	1
32	70	9	1	8	4	90	2	8	3	60,5	62,5	1,5
	75	9	1	8	4	100	3	12	5,5	65,5	68,5	1,5
40	80	9	1	8	4	110	3	12	5,5	70,5	73,5	1,5
	85	9	1	8	4	120	3	12	5,5	75,5	78,5	1,5
50	90	9	1	8	4	130	3	12	5,5	80,5	83,5	1,5
	95	9	1	8	4	140	3	12	5,5	85,5	88,5	1,5
63	100	9	1	8	8	145	3	12	5,5	90,5	93,5	1,5
	105	9	1	8	8	155	3	12	5,5	95,5	98,5	1,5
80	110	9	1	8	8	165	3	12	5,5	100,5	103,5	1,5
	115	9	1	8	8	175	3	12	5,5	105,5	108,5	1,5
100	125	11	1	10	8	200	5	16	6,5	120,7	122,7	2,5
	130	11	1	10	8	210	5	16	6,5	125,7	127,7	2,5
160	145	11	1	10	8	225	5	16	6,5	135,7	137,7	2,5
	150	11	1	10	8	235	5	16	6,5	140,7	142,7	2,5
200	175	11	1	10	12	285	5	16	6,5	185,7	187,7	2,5
	180	11	1	10	12	295	5	16	6,5	190,7	192,7	2,5
250	200	11	1	10	12	335	5	16	6,5	220,7	222,7	2,5
	210	11	1	10	12	345	5	16	6,5	230,7	232,7	2,5
320	260	14	2	12	12	425	5	20	8,5	280,8	282,8	2,5
	270	14	2	12	12	435	5	20	8,5	290,8	292,8	2,5
400	310	14	2	12	16	510	8	20	10	340,8	342,8	4
	320	14	2	12	16	520	8	20	10	350,8	352,8	4
500	395	14	2	12	16	610	8	20	10	410,8	412,8	4
	400	14	2	12	16	620	8	20	10	420,8	422,8	4
630	580	14	2	12	16	610	8	20	10	550,8	552,8	4
	720	14	2	12	20	750	10	24	12	691	701	5

\* See 3.2. It should be noted that the nominal bores recommended above 630 are: 800, 1 000, 1 250, 1 600, 2 000 and 2 500.

\*\* In the absence of a standard for the drawn wire used for the rings, the following tolerances are suggested:  $\pm 0,02$  mm for  $K=2$  mm  
 $\pm 0,025$  mm for  $K=3$  and 5 mm  
 $\pm 0,03$  mm for  $K=8$  mm

\*\*\* In no case should the surface of the rotatable flange protrude past the collar face when assembled.

## Annex A

### Linear sealing loads

(This annex forms an integral part of the standard.)

The values given in table 4 have been calculated for each bolted flange under the following conditions of use:

$\sigma$  is the resulting linear load, in newtons per millimetre, exerted on a unit length of an elastomer O-ring by the uniform tightening of  $n$  bolts to a stress of 200 N/mm<sup>2</sup>, the mean diameter of the sealing ring, before compression, being equal to  $(d_1 + d_2)$  mm.

Hence

$$\sigma = \frac{200 ns}{\pi(d_1 + d_2)}$$

where

$s$  is the cross-sectional area of the core of the bolt, in square millimetres;

$d_1$  is the inside diameter of the sealing ring, in millimetres;

$d_2$  is the cross-sectional diameter of the sealing ring before compression, in millimetres.

iTeh STANDARD PREVIEW  
(standards.iteh.ai)

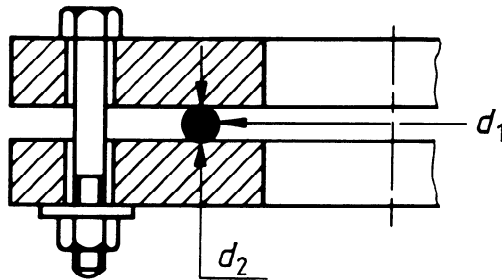

**Figure 4 – Detail of a bolt assembly with O-ring**

**Table 4 – Linear sealing loads**

Nominal bore mm	Typical values of $\sigma$ N/mm
10	185
16	154
20	132
25	116
32	177
40	146
50	124
63	96
80	164
100	138
125	184
160	157
200	174
250	143
320	162
400	179
500	146
630	150
800	144
1 000	156



## Annex B

### Bores for vacuum flanges and required outside tube diameters

(This annex forms an integral part of the standard.)

This annex gives both the bores for the vacuum flanges defined in this International Standard and the outside diameters for tubes to be used with these flanges.

**Table 5 – Bores for vacuum flanges**

Dimensions in millimetres

Nominal bore	$A^*$
10	10
16	16
20	21
25	24
32	34
40	41
50	51
63	70
80	83
100	102
125	127
160	153
200	213
250	261
320	318
400	400
500	501
630	651
800	800
1 000	1 000

\* Dimension  $A$  is given for guidance only and depends on the tube and the method of welding.

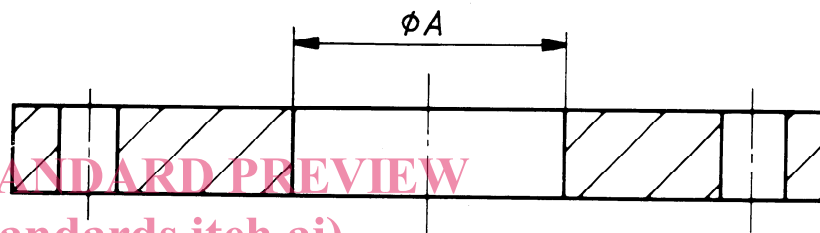

**Figure 5 – Bores for vacuum flanges**

ISO 1609:1986

<https://standards.iteh.ai/catalog/standards/sist/79a915be-59ce-4010-946c-98087a6171c2/iso-1609-1986>

**Table 6 – Flange recess**

Dimensions in millimetres

Nominal bore	$A_1^*$
10	12,2
16	17,2
20	22,2
25	26,2
32	34,2
40	41,2
50	52,2

\* Tolerance for  $A_1$ :  $^{+0,2}_0$  mm

This recess permits the use of centrally located sealing ring carriers.

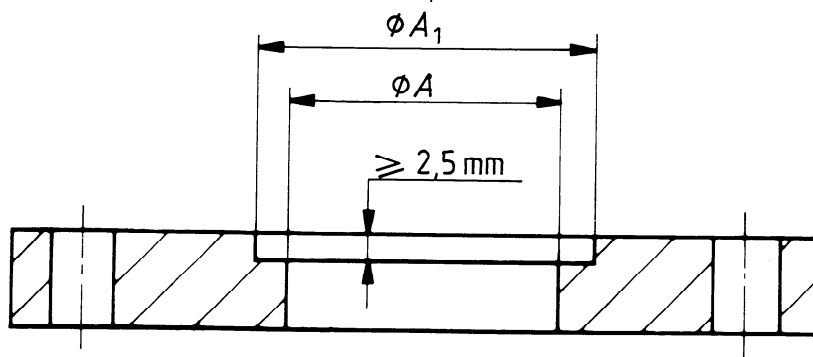

**Figure 6 – Bore for vacuum flanges with recess**