**Non-ducted portable air-cooled air
conditioners and air-to-air heat
pumps having a single exhaust duct —
Testing and rating for performance**

*Climatiseurs refroidis par air et pompes à chaleur portables
non raccordés à simple conduit — Essais et détermination des
caractéristiques des performances*

iTeh STANDARD PREVIEW
(standards.iteh.ai)

ISO 18326:2018

<https://standards.iteh.ai/catalog/standards/sist/78314326-64b3-4e57-bed4-5365fd6ab4b5/iso-18326-2018>



iTeh STANDARD PREVIEW
(standards.iteh.ai)

ISO 18326:2018

<https://standards.iteh.ai/catalog/standards/sist/78314326-64b3-4e57-bed4-5365fd6ab4b5/iso-18326-2018>



COPYRIGHT PROTECTED DOCUMENT

© ISO 2018

All rights reserved. Unless otherwise specified, or required in the context of its implementation, no part of this publication may be reproduced or utilized otherwise in any form or by any means, electronic or mechanical, including photocopying, or posting on the internet or an intranet, without prior written permission. Permission can be requested from either ISO at the address below or ISO's member body in the country of the requester.

ISO copyright office
CP 401 • Ch. de Blandonnet 8
CH-1214 Vernier, Geneva
Phone: +41 22 749 01 11
Fax: +41 22 749 09 47
Email: copyright@iso.org
Website: www.iso.org

Published in Switzerland

Contents

	Page
Foreword	v
Introduction	vi
1 Scope	1
2 Normative references	1
3 Terms and definitions	1
4 Symbols	5
5 Cooling tests	7
5.1 Cooling capacity test.....	7
5.1.1 General conditions.....	7
5.1.2 Condensate containers.....	7
5.1.3 Tests using supplementary water evaporation feature.....	7
5.1.4 Temperature conditions.....	8
5.1.5 Airflow conditions — Air quantity.....	9
5.1.6 Test conditions.....	9
5.2 Maximum cooling performance test.....	9
5.2.1 General conditions.....	9
5.2.2 Temperature conditions.....	9
5.2.3 Temperature conditions.....	10
5.2.4 Performance requirements.....	10
5.3 Condensate control and enclosure sweat performance test.....	11
5.3.1 General conditions.....	11
5.3.2 Temperature conditions.....	11
5.3.3 Airflow conditions.....	11
5.3.4 Test conditions.....	11
5.3.5 Performance requirements.....	11
6 Heating tests	12
6.1 Heating capacity tests.....	12
6.1.1 General conditions.....	12
6.1.2 Temperature conditions.....	13
6.1.3 Airflow conditions — Air quantity.....	13
6.1.4 Test conditions.....	13
6.2 Maximum heating performance test.....	14
6.2.1 General conditions.....	14
6.2.2 Temperature conditions.....	14
6.2.3 Airflow conditions.....	14
6.2.4 Test conditions.....	14
7 Test methods and uncertainties of measurements	15
7.1 Test methods.....	15
7.1.1 General.....	15
7.1.2 Calorimeter test method.....	15
7.1.3 Capacity tests.....	15
7.2 Uncertainties of measurement.....	15
7.3 Test tolerances for steady-state cooling and heating tests.....	15
7.3.1 Variation of individual observations.....	15
7.3.2 Variation of average observations.....	16
7.3.3 Sampling rate.....	16
7.3.4 Tolerances for capacity calculations.....	17
7.4 Test tolerances for performance tests.....	17
8 Test capacity results	17
8.1 Capacity results.....	17
8.1.1 General.....	17

8.1.2	Adjustments.....	17
8.1.3	Cooling capacity calculations.....	18
8.1.4	Heating capacity calculations.....	18
8.2	Data to be recorded.....	18
8.3	Test report.....	18
8.3.1	General information.....	18
8.3.2	Capacity tests.....	20
9	Marking provisions.....	20
9.1	Nameplate requirements.....	20
9.2	Nameplate information.....	20
10	Publication of ratings.....	21
10.1	Standard ratings.....	21
10.1.1	General.....	21
10.1.2	Units.....	21
10.1.3	EER and COP.....	21
10.1.4	Capacity rating and test voltage.....	21
10.2	Other ratings.....	21
Annex A	(normative) Test requirements.....	22
Annex B	(normative) Units with a supplementary water-tank — Determining the duration of supplementary water evaporation feature.....	26
Annex C	(informative) Airflow measurement.....	28
Annex D	(normative) Calorimeter test method.....	34
Annex E	(informative) Cooling condensate measurements.....	44
Annex F	(informative) Example of multiple point air sampling apparatus.....	45
Bibliography	47

<https://standards.iteh.ai/catalog/standards/sist/78314326-64b3-4e57-bed4-5365fd6ab4b5/iso-18326-2018>

Foreword

ISO (the International Organization for Standardization) is a worldwide federation of national standards bodies (ISO member bodies). The work of preparing International Standards is normally carried out through ISO technical committees. Each member body interested in a subject for which a technical committee has been established has the right to be represented on that committee. International organizations, governmental and non-governmental, in liaison with ISO, also take part in the work. ISO collaborates closely with the International Electrotechnical Commission (IEC) on all matters of electrotechnical standardization.

The procedures used to develop this document and those intended for its further maintenance are described in the ISO/IEC Directives, Part 1. In particular the different approval criteria needed for the different types of ISO documents should be noted. This document was drafted in accordance with the editorial rules of the ISO/IEC Directives, Part 2 (see www.iso.org/directives).

Attention is drawn to the possibility that some of the elements of this document may be the subject of patent rights. ISO shall not be held responsible for identifying any or all such patent rights. Details of any patent rights identified during the development of the document will be in the Introduction and/or on the ISO list of patent declarations received (see www.iso.org/patents).

Any trade name used in this document is information given for the convenience of users and does not constitute an endorsement.

For an explanation on the voluntary nature of standards, the meaning of ISO specific terms and expressions related to conformity assessment, as well as information about ISO's adherence to the World Trade Organization (WTO) principles in the Technical Barriers to Trade (TBT) see the following URL: www.iso.org/iso/foreword.html.

This document was prepared by Technical Committee ISO/TC 86, *Refrigeration and air-conditioning*, Subcommittee SC 6, *Testing and rating of air-conditioners and heat pumps*.

<https://standards.iteh.ai/catalog/standards/sist/78314326-64b3-4e57-bed4-5365fd6ab4b5/iso-18326-2018>

Introduction

Single duct portable air conditioners and heat pumps can be selected for their ease and rapidity of use, handling and installation, in particular when the use of other categories of air conditioners is not convenient or forbidden, for example in rented or holiday houses or in historical buildings where an external unit cannot be placed outdoors.

The operational mode and features of such appliances are quite different from those of the well-known non-ducted air conditioners and heat pumps largely diffused worldwide and covered by ISO 5151.

There are presently no internationally recognized standards for single duct portable air conditioners and heat pumps. The economic operators involved in the production and distribution of such products face significant problems in verifying and declaring performance and energy consumption data in an objective and internationally recognized way.

This being considered, ISO/TC 86/SC 6 decided to prepare a specific standard for single duct portable air conditioners and heat pumps.

During the discussion of its contents it was acknowledged that it is necessary to provide the users with information on the specific characteristics of single duct portable air conditioners and heat pumps, on their correct installation and on their use. This will be covered by a future Amendment to this document which is currently under discussion.

iTeh STANDARD PREVIEW (standards.iteh.ai)

[ISO 18326:2018](https://standards.iteh.ai/catalog/standards/sist/78314326-64b3-4e57-bed4-5365fd6ab4b5/iso-18326-2018)

<https://standards.iteh.ai/catalog/standards/sist/78314326-64b3-4e57-bed4-5365fd6ab4b5/iso-18326-2018>

Non-ducted portable air-cooled air conditioners and air-to-air heat pumps having a single exhaust duct — Testing and rating for performance

1 Scope

This document specifies the standard conditions for capacity and efficiency ratings of non-ducted portable air-cooled air conditioners having a single exhaust duct and non-ducted portable air-cooled heat pumps having a single exhaust duct. Such air conditioners and heat pumps may include an evaporatively cooled condenser cooled by air and the evaporation of:

- a) condensate collected from the evaporator;
- b) external supplementary water stored in a supplementary water tank; or
- c) both a) and b).

This document also specifies the test methods for determining the capacity and efficiency ratings.

This document applies to equipment that is factory-made, electrically driven and uses mechanical compression. This document is applicable to equipment utilizing one or more refrigeration systems.

This document is not applicable to the rating and testing of the following:

- i) Water-source heat pumps or water-cooled air conditioners;
- ii) Multi-split-system air conditioners and air-to-air heat pumps (see ISO 15042:2017 for the testing of such equipment);
- iii) Individual assemblies not constituting a complete refrigeration system;
- iv) Equipment using the absorption refrigeration cycle;
- v) Ducted equipment (see ISO 13253:2017 for the testing of such equipment);
- vi) Evaporative coolers or any other cooling systems that are not of the vapour compression type;
- vii) Dehumidifiers;
- viii) Spot coolers.

2 Normative references

The following documents are referred to in the text in such a way that some or all of their content constitutes requirements of this document. For dated references, only the edition cited applies. For undated references, the latest edition of the referenced document (including any amendments) applies.

ISO 817, *Refrigerants — Designation and safety classification*

3 Terms and definitions

For the purposes of this document, the following terms and definitions apply.

ISO and IEC maintain terminological databases for use in standardization at the following addresses:

— IEC Electropedia: available at <http://www.electropedia.org/>

— ISO Online browsing platform: available at <https://www.iso.org/obp>

**3.1
bypassed indoor airflow**

rate of flow of conditioned air directly from the indoor-side outlet to the indoor-side inlet of the equipment

Note 1 to entry: See [Figure 1](#).

**3.2
coefficient of performance
COP**

ratio of the heating capacity to the total power input to the device at any given set of rating conditions

Note 1 to entry: Where the COP is stated without an indication of units, it is understood that it is derived from watts/watt.

**3.3
conditioned space**

enclosed space, room or zone to which conditioned air is delivered

**3.4
dehumidifier**

encased assembly designed to remove moisture from its surrounding atmosphere using either an electrically operated refrigeration system or a desiccant type of material including a means to circulate air and a drain arrangement for collecting and storing and/or disposing of the condensate

**3.5
total power input**

P_t
average electrical power input to the equipment as measured during the test

Note 1 to entry: Total power input is expressed in units of watts.
<https://standards.iteh.ai/catalog/standards/sist/78314326-64b3-4e57-bed4-55651d0ab405/iso-18326-2018>

**3.6
ventilation airflow**

rate of flow of air introduced to the conditioned space through the equipment

**3.7
equalizer opening airflow**

rate of flow of air from the outdoor side through the equalizer opening in the partition wall of a calorimeter to the indoor side

Note 1 to entry: See [Figure 1](#).

**3.8
evaporatively cooled condenser**

heat exchanger that condenses refrigerant vapour by rejecting heat to a water and air mixture causing the water to evaporate and increase the enthalpy of air

Note 1 to entry: Desuperheating and sub-cooling of the refrigerant may also occur.

**3.9
exhaust airflow**

rate of flow of air from the indoor side through the equipment to the outdoor side

Note 1 to entry: See [Figure 1](#).

**3.10
full-load operation**

operation with the equipment and controls configured for the maximum continuous duty refrigeration capacity specified by the manufacturer and allowed by the unit controls

3.11**heating capacity**

amount of heat that the equipment can add to the conditioned space (but not including supplementary heat) in a defined interval of time

Note 1 to entry: Heating capacity is expressed in units of watts. Manually selectable supplementary heaters are disabled during capacity tests, but any automatic supplementary heaters are permitted to operate.

3.12**indoor compartment****indoor-side compartment**

testing room simulating the conditioned space (and containing the tested appliance)

Note 1 to entry: See [Figure 1](#).

3.13**indoor discharge airflow**

rate of flow of air from the outlet of the equipment into the conditioned space

Note 1 to entry: See [Figure 1](#).

3.14**indoor heat exchanger**

heat exchanger which is designed to remove heat from the indoor part of the building or to transfer heat to it

Note 1 to entry: In the case of an air conditioner or heat pump operating in the cooling mode, this is the evaporator. In the case of an air conditioner or heat pump operating in the heating mode, this is the condenser.

3.15**indoor intake airflow**

rate of flow of air into the equipment from the conditioned space

Note 1 to entry: See [Figure 1](#).

3.16**latent cooling capacity**

amount of latent heat that the equipment can remove from the conditioned space in a defined interval of time

Note 1 to entry: Latent cooling capacity is expressed in units of watts.

Note 2 to entry: "Latent cooling capacity" is also known as "room dehumidifying capacity".

3.17**leakage airflow**

rate of flow of air interchanged between the indoor side and outdoor side through the equipment as a result of its construction features and sealing techniques

Note 1 to entry: See [Figure 1](#).

3.18**non-ducted portable air-cooled air conditioner having a single exhaust duct**

encased assembly, designed primarily to provide free delivery of conditioned air to an enclosed space, room or zone which takes its source of air for cooling the condenser from the conditioned space, and discharges this air through a duct to the outdoor space

Note 1 to entry: Such air conditioners comprise a primary source of refrigeration for cooling and dehumidification. They can also include means for heating other than a heat pump, as well as means for circulating, cleaning, humidifying, ventilating or exhausting air.

3.19

non-ducted portable air-cooled heat pump having a single exhaust duct

encased assembly designed primarily to provide free delivery of conditioned air to an enclosed space, room or zone and includes a prime source of refrigeration for heating and which takes its source of air for the evaporator from the conditioned space, and discharges this air through a duct to the outdoor space

Note 1 to entry: Such heat pumps can be constructed to remove heat from the conditioned space and discharge it to a heat sink if cooling and dehumidification are desired from the same equipment. They can also include means for circulating, cleaning, humidifying, ventilating or exhausting air.

3.20

outdoor compartment

compartment where the exhaust air is rejected through the duct of single duct air conditioner

3.21

outdoor exhaust airflow

discharge rate of flow of air from the equipment through the exhaust duct

Note 1 to entry: See [Figure 1](#).

3.22

outdoor heat exchanger

heat exchanger that is designed to transfer heat to the outdoor ambient environment or to remove heat from it

Note 1 to entry: In the case of an air conditioner or heat pump operating in the cooling mode, this is the condenser. In the case of an air conditioner or heat pump operating in the heating mode, this is the evaporator.

3.23

rated frequency

frequency shown on the nameplate of the equipment

3.24

rated voltage

voltage shown on the nameplate of the equipment

3.25

sensible cooling capacity

amount of sensible heat that the equipment can remove from the conditioned space in a defined interval of time

Note 1 to entry: Sensible cooling capacity is expressed in units of watts.

3.26

sensible heat ratio

SHR

ratio of the sensible cooling capacity to the total cooling capacity

3.27

spot cooler

encased assembly air conditioner that lies wholly within a conditioned space and that draws air for both the evaporator and condenser from the conditioned space and expels both of these back into the conditioned space

Note 1 to entry: A spot cooler is usually portable.

3.28

standard air

dry air at 20 °C and at a standard barometric pressure of 101,325 kPa, having a mass density of 1,204 kg/m³

3.29**supplementary water tank**

tank designed as an integral part of the unit to contain external supplementary water which is fed to the evaporatively cooled condenser

3.30**total cooling capacity**

amount of sensible and latent heat that the equipment can remove from the conditioned space in a defined interval of time

Note 1 to entry: Total cooling capacity is expressed in units of watts.

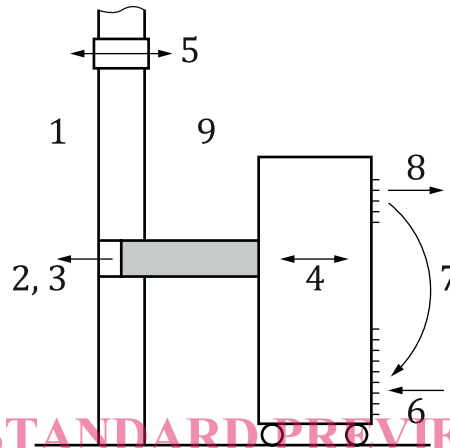

iTeh STANDARD PREVIEW
(standards.iteh.ai)

Key

- 1 outdoor compartment (3.20)
- 2 outdoor exhaust airflow (3.21)
- 3 exhaust airflow (3.9)
- 4 leakage airflow (3.17)
- 5 equalizer opening airflow (3.7)
- 6 indoor intake airflow (3.15)
- 7 bypassed indoor airflow (3.1)
- 8 indoor discharge airflow (3.13)
- 9 indoor compartment (3.12)

Figure 1 — Airflow diagram illustrating the airflow definitions

4 Symbols

Symbol	Description	Unit
A_l	coefficient, heat leakage	J/(s·K)
A_n	area, nozzle	m ²
C_d	nozzle discharge coefficient	a
c_{pa}	specific heat of air, moist air	J/(kg·K)
c_{pw}	specific heat of water	J/(kg·K)
D_n	nozzle throat diameter	m
D_t	outside diameter of refrigerant tube	m
f	factor, dependent on temperature, for R_e	—
h_{w1}	specific enthalpy of water or steam supplied to indoor side compartment	J/kg
h_{w2}	specific enthalpy of condensed moisture leaving indoor side compartment	J/kg

Symbol	Description	Unit
h_{w3}	specific enthalpy of condensed moisture leaving outdoor-side compartment	J/kg
h_{w4}	specific enthalpy of the water supplied to the outdoor side test chamber	J/kg
h_{w5}	specific enthalpy of the condensed water (in the case of H1 test condition) and the frost, respectively (in the case of H2 or H3 test conditions) in the test unit	J/kg
K_1	latent heat of vaporization of water ($2\,460 \times 10^3$ J/kg at 15 °C)	J/kg
Re	Reynolds number	—
p_a	barometric pressure	kPa
p_c	test chamber equalization pressure	Pa
p_n	absolute pressure at nozzle throat	Pa
p_v	velocity pressure at nozzle throat or static pressure difference across nozzle	Pa
ϕ_{ci}	heat removed from indoor-side compartment	W
ϕ_c	heat removed by cooling coil in outdoor-side compartment	W
ϕ_{lp}	heat leakage into indoor-side compartment through partition separating indoor side from outdoor side	W
ϕ_{li}	heat leakage into indoor-side compartment through walls, floor and ceiling	W
ϕ_{lci}	latent cooling capacity (indoor-side data)	W
ϕ_{sc}	sensible cooling capacity	W
ϕ_{sci}	sensible cooling capacity (indoor-side data)	W
ϕ_{ho}	heating capacity, outdoor-side compartment	W
ϕ_{tci}	total cooling capacity (indoor-side data)	W
ϕ_{tco}	total cooling capacity (outdoor-side data)	W
ϕ_{thi}	total heating capacity (indoor-side data)	W
ϕ_{tho}	total heating capacity (outdoor-side data)	W
ΣP_{ic}	other power input to the indoor-side compartment (e.g. illumination, electrical and thermal power input to the compensating device, heat balance of the humidification device)	W
ΣP_{oc}	sum of all total power input to the outdoor-side compartment, not including power to the equipment under test	W
P_t	total power input to equipment	W
q_m	air-mass flow rate	kg/s
q_{mo}	airflow, outdoor, measured	m ³ /s
q_v	air-volume flow rate	m ³ /s
q_{wo}	water mass flow supplied to the outside compartment for maintaining the test conditions	kg/s
q_{wc}	rate at which water vapour is condensed by the equipment	g/s
t_a	temperature, ambient	°C
v_a	velocity of air, at nozzle	m/s
v_n	specific volume of dry air portion of mixture at nozzle	m ³ /kg
v'_n	specific volume of air-water vapour mixture at nozzle	m ³ /kg
μ	kinematic viscosity of air	kg/m·s
W_{i1}	specific humidity of air entering indoor side ^b	kg/kg ^b
W_{i2}	specific humidity of air leaving indoor side ^b	kg/kg ^b

Symbol	Description	Unit
W_n	specific humidity at nozzle inlet ^b	kg/kg ^b
W_r	water vapour (rate) condensed by the equipment	kg/s

^a Dimensionless value.

^b The mass of dry air. The mass, kg, of the denominator in this unit is based on dry air (DA). For units practically used in the air conditioning field, gkg, (DA)h is very often used for the denominator. Example J/kg(DA), m³/kg (DA), kg/kg(DA).

NOTE All parameters are in relation to the unit being tested unless specified otherwise.

5 Cooling tests

5.1 Cooling capacity test

5.1.1 General conditions

5.1.1.1 All equipment within the scope of this document shall have the cooling capacities and energy efficiency ratios determined in accordance with the provisions of this document and rated at the cooling test conditions specified in [Table 1](#). All tests shall be carried out in accordance with the requirements of [Annex A](#) and the test methods specified in [Clause 7](#). All tests shall be conducted with the equipment functioning at full-load operation, as defined in [3.10](#). The electrical input values used for rating purposes shall be measured during the cooling capacity test.

Units that evaporate condensate collected from the evaporator shall be allowed to do so during the capacity test (see [5.1.2](#)). Units that have a supplementary water tank intended to contain supplementary water that is fed to the evaporatively cooled condenser shall have capacity tests performed with and without this feature operating, subject to the requirements of [5.1.3](#) and [Annex B](#). If a unit automatically turns off once the supplementary water tank becomes empty, a capacity test with this feature operating is the only capacity test required. See [Table B.1](#) for a summary of these requirements.

If the manufacturer of equipment having a variable-speed compressor does not provide information on the full-load frequency and on how to achieve it during the cooling capacity test, the equipment shall be operated with its thermostat or controller set to its minimum allowable temperature setting.

5.1.2 Condensate containers

5.1.2.1 The duration of the cooling capacity test shall not be interrupted by a full condensate container triggering a cut-off switch. If necessary, condensate containers shall be modified to drain away excess condensate into a larger container in the test chamber before the volume that activates the cut-off switch is reached.

NOTE Many units have an in-built drain hose to facilitate this.

5.1.3 Tests using supplementary water evaporation feature

5.1.3.1 Performance and cooling capacity tests shall be performed using the supplementary water evaporation feature as per the manufacturer's instructions, if applicable. Water added to a unit's supplementary water tank shall be 35 °C ± 1 °C. All performance parameters for the standard rating test shall also be recorded for any cooling capacity tests that use the supplementary water evaporation feature. The test procedure includes determining the duration of time that the supplementary water tank can operate at standard cooling rating conditions. These procedures are specified in [Annex B](#).

NOTE Some units are fitted with a supplementary water evaporation feature designed to provide additional water for the evaporatively cooled condenser and/or compressor. They generally require the user to fill a supplementary water tank and manually select an operational mode via the unit's control panel or remote control that turns this supplementary water evaporation feature on. This operational mode can override other thermostat and fan settings and is designed to achieve higher cooling capacities and greater energy efficiency while this feature is active. When these units deactivate their supplementary water evaporation feature (for instance, when they detect that there is insufficient water in the supplementary water tank), they can automatically revert to cooling without the aid of the supplementary water evaporation feature, or they can switch themselves off.

5.1.4 Temperature conditions

The temperature conditions stated in Table 1 shall be considered standard rating conditions for the determination of cooling capacity.

If the unit is rated for operation at two frequencies or, in some cases, if the equipment has a dual-rated voltage, then the cooling capacity test shall be conducted at each frequency and voltage in accordance with the conditions of Tables 1 and 2.

Table 1 — Cooling capacity rating conditions

Parameter	Standard rating conditions
Temperature of air entering indoor-side:	
— dry-bulb	35 °C
— wet-bulb	24 °C
Temperature of air entering outdoor-side:	
— dry-bulb	35 °C
— wet-bulb	24 °C
Test frequency ^a	Rated frequency
Test voltage	See Table 2

^a Equipment with dual-rated frequencies shall be tested at each frequency.

NOTE The measured performance of single duct, portable air conditioners and heat pumps is sensitive to even a small difference in the enthalpy of the air entering the indoor chamber from the outdoor chamber. Therefore, it is desirable to have the indoor and outdoor chamber temperatures as close as possible during the tests.

Table 2 — Voltages for capacity and performance tests

Rated (nameplate) voltage ^a V	Test voltage V
90 to 109	100
110 to 127	115
180 to 207	200
208 to 253	230
254 to 341	265
342 to 420	400
421 to 506	460
507 to 633	575

^a For equipment with dual-rated voltages such as 115/230 and 220/440, the test voltages would be 115 V and 230 V in the first example, and 230 V and 460 V in the second example. For equipment with an extended voltage range, such as 110 V to 120 V or 220 V to 240 V, the test voltage would be 115 V or 230 V, respectively. Where the extended voltage range spans two or more of the rated voltage ranges, the mean of the rated voltages shall be used to determine the test voltage from the table.

EXAMPLE For equipment with an extended voltage range of 200 V to 220 V, the test voltage would be 230 V, based on the mean voltage of 210 V.

5.1.5 Airflow conditions — Air quantity

Tests shall be conducted at standard rating conditions (see [Table 1](#)) with 0 Pa static pressure maintained at the air discharge of the equipment and with the refrigeration means in operation if required. All air quantities shall be expressed as litres per second (L/s) of standard air, as defined in [3.28](#).

Airflow measurements should be made in accordance with the provisions specified in [Annex C](#), as appropriate, as well as the provisions established in other appropriate appendices of this document.

NOTE Additional guidance for making airflow measurements can be found in ISO 3966 and ISO 5167-1.

5.1.6 Test conditions

5.1.6.1 General

Tests shall be conducted under the rating conditions with no changes made in fan speed or system resistance to correct for variations from the standard barometric pressure (see [3.28](#)).

5.1.6.2 Preconditions

The test room reconditioning apparatus and the equipment under test shall be operated until equilibrium conditions, as required by [7.3](#), are attained. Equilibrium conditions shall be maintained for not less than 1 h before capacity test data are recorded.

5.1.6.3 Testing requirements

The test shall provide for the determination of the sensible, latent and total cooling capacities as determined in the indoor-side compartment. See [5.1.1](#), [5.1.3](#) and [Annex B](#) for additional requirements associated with units that have a supplementary water tank.

5.1.6.4 Duration of test

The data shall be recorded at equal intervals as required by [7.3.3](#). The recording of the data shall continue for at least a 30 min period during which the tolerances specified in [7.3](#) shall be met. Many units exhibit pronounced cyclic behaviour in cooling mode. If a unit exhibits this type of cyclic behaviour, data shall be recorded and averaged over at least 120 min.

5.2 Maximum cooling performance test

5.2.1 General conditions

The test shall be conducted with the equipment functioning at full-load operation, as defined in [3.10](#). If the unit includes an in-built condensate collection and evaporation process, it shall be allowed to function (see [5.1.2](#)). Units with a supplementary water tank may require two tests, subject to the requirements of [Annex B](#). This feature shall be operated in accordance with manufacturer's instructions, if applicable.

The test voltages in [Table 2](#) shall be maintained at the specified percentages under running conditions. In addition, the test voltage shall be adjusted so that it is not less than 86 % of the rated voltage at the moment of restarting the equipment after the shutdown required by [5.2.4.2](#). The determination of cooling capacity and electrical power input is not required for this performance test. The unit shall be set up as specified in [Annex A](#).

5.2.2 Temperature conditions

The conditions, which shall be used during the maximum cooling test, are given in [Table 3](#). If applicable, water added to a supplementary water tank shall be at 35 °C ± 1 °C.