



Designation: D7400 – 08

Standard Test Methods for Downhole Seismic Testing¹

This standard is issued under the fixed designation D7400; the number immediately following the designation indicates the year of original adoption or, in the case of revision, the year of last revision. A number in parentheses indicates the year of last reappraisal. A superscript epsilon (ϵ) indicates an editorial change since the last revision or reappraisal.

1. Scope*

1.1 These test methods are limited to the determination of the interval velocities from arrival times and relative arrival times of compression (P) and vertically (SV) and horizontally (SH) polarized shear (S) seismic waves which are generated near surface and travel down to an array of vertically installed seismic sensors. A preferred method intended to obtain data for use on critical projects where the highest quality data is required is included. Also included is an optional method intended for use on projects which do not require measurements of a high degree of precision.

1.2 Various applications of the data will be addressed and acceptable procedures and equipment, such as seismic sources, receivers, and recording systems will be discussed. Other items addressed include source-to-receiver spacing, drilling, casing, grouting, a procedure for borehole installation, and conducting actual borehole and seismic cone tests. Data reduction and interpretation is limited to the identification of various seismic wave types, apparent velocity relation to true velocity, example computations, use of Snell's law of refraction, and assumptions.

1.3 There are several acceptable devices that can be used to generate a high-quality P or SV source wave or both and SH source waves. Several types of commercially available receivers and recording systems can also be used to conduct an acceptable downhole survey. Special consideration should be given to the types of receivers used and their configuration. Heavily-damped sensors should not be used so that spectral smearing, phase shifting, and latency response between sensors is avoided. These test methods primarily concern the actual test procedure, data interpretation, and specifications for equipment which will yield uniform test results.

1.4 All recorded and calculated values shall conform to the guide for significant digits and rounding established in Practice D6026.

¹ This test method is under the jurisdiction of ASTM Committee D18 on Soil and Rock and is the direct responsibility of Subcommittee D18.09 on Cyclic and Dynamic Properties of Soils.

Current edition approved June 1, 2008. Published July 2008. Originally approved in 2007. Last previous edition approved in 2007 as D7400 – 07. DOI: 10.1520/D7400-08.

1.4.1 The procedures used to specify how data are collected/recorded and calculated in these test methods are regarded as the industry standard. In addition, they are representative of the significant digits that should generally be retained. The procedures used do not consider material variation, purpose for obtaining the data, special purpose studies, or any considerations for the user's objectives; and it is common practice to increase or reduce significant digits of reported data to be commensurate with these considerations. It is beyond the scope of these test methods to consider significant digits used in analysis methods for engineering design.

1.4.2 Measurements made to more significant digits or better sensitivity than specified in these test methods shall not be regarded a nonconformance with this standard.

1.5 This standard is written using SI units. Inch-pound units are provided for convenience. The values stated in inch pound units may not be exact equivalents; therefore, they shall be used independently of the SI system. Combining values from the two systems may result in nonconformance with this standard.

1.5.1 The gravitational system of inch-pound units is used when dealing with inch-pound units. In this system, the pound (lbf) represents a unit of force (weight), while the unit for mass is slugs. The rationalized slug unit is not given, unless dynamic ($F = ma$) calculations are involved.

1.5.2 It is common practice in the engineering/construction profession to concurrently use pounds to represent both a unit of mass (lbm) and of force (lbf). This implicitly combines two separate systems of units; that is, the absolute system and the gravitational system. It is scientifically undesirable to combine the use of two separate sets of inch-pound units within a single standard. As stated, this standard includes the gravitational system of inch-pound units and does not use/present the slug unit for mass. However, the use of balances or scales recording pounds of mass (lbm) or recording density in lbm/ft³ shall not be regarded as nonconformance with this standard.

1.6 *This standard does not purport to address all of the safety concerns, if any, associated with its use. It is the responsibility of the user of this standard to establish appropriate safety and health practices and determine the applicability of regulatory limitations prior to use.*

*A Summary of Changes section appears at the end of this standard

2. Referenced Documents

2.1 *ASTM Standards*:²

D653 Terminology Relating to Soil, Rock, and Contained Fluids

D3740 Practice for Minimum Requirements for Agencies Engaged in Testing and/or Inspection of Soil and Rock as Used in Engineering Design and Construction

D4428/D4428M Test Methods for Crosshole Seismic Testing

D5778 Test Method for Electronic Friction Cone and Piezocone Penetration Testing of Soils

D6026 Practice for Using Significant Digits in Geotechnical Data

3. Terminology

3.1 *Definitions*:

3.1.1 For definitions of terms used in these test methods, see Terminology **D653**.

4. Summary of Test Method

4.1 The Downhole Seismic Test makes direct measurements of compression (P-) or shear (S-) wave velocities, or both, in a borehole advanced through soil or rock or in a cone penetration test sounding. It is similar in several respects to the Crosshole Seismic Test Method (Test Methods **D4428/D4428M**). A seismic source is used to generate a seismic wave train at the ground surface offset horizontally from the top of a cased borehole. Downhole receivers are used to detect the arrival of the seismic wave train. The downhole receiver(s) may be positioned at selected test depths in a borehole or advanced as part of the instrumentation package on an electronic cone penetrometer (Test Method **D5778**). The seismic source is connected to and triggers a data recording system that records the response of the downhole receiver(s), thus measuring the travel time of the wave train between the source and receiver(s). Measurements of the arrival times (travel time from source to sensor) of the generated P- and S- waves are then made so that the low strain ($<10^{-4}$ %) in-situ P-wave and S-wave velocities can be determined. The calculated seismic velocities are used to characterize the natural or man-made (or both) properties of the stratigraphic profile.

5. Significance and Use

5.1 The seismic downhole method provides a designer with information pertinent to the seismic wave velocities of the materials in question (1). The P-wave and S-wave velocities are directly related to the important geotechnical elastic constants of Poisson's ratio, shear modulus, bulk modulus, and Young's modulus. Accurate in-situ P-wave and S-wave velocity profiles are essential in geotechnical foundation designs. These parameters are used in both analyses of soil behavior under both static and dynamic loads where the elastic constants are input variables into the models defining the different states

of deformations such as elastic, elasto-plastic, and failure. Another important use of estimated shear wave velocities in geotechnical design is in the liquefaction assessment of soils.

5.2 A fundamental assumption inherent in the test methods is that a laterally homogeneous medium is being characterized. In a laterally homogeneous medium the source wave train trajectories adhere to Snell's law of refraction. Another assumption inherent in the test methods is that the stratigraphic medium to be characterized can have transverse isotropy. Transverse isotropy is a particularly simple form of anisotropy because velocities only vary with vertical incidence angle and not with azimuth. By placing and actuating the seismic source at offsets rotated 90° in plan view, it may be possible to evaluate the transverse anisotropy of the medium.

NOTE 1—The quality of the results produced by this standard is dependent on the competence of the personnel performing it, and the suitability of the equipment and facilities. Agencies that meet the criteria of Practice **D3740** are generally considered capable of competent and objective testing/sampling/inspection/etc. Users of this standard are cautioned that compliance with Practice **D3740** does not in itself assure reliable results. Reliable results depend on many factors; Practice **D3740** provides a means of evaluating some of those factors.

6. Apparatus

6.1 The basic data acquisition system consists of the following:

6.1.1 *Energy Sources*— These energy sources are chosen according to the needs of the survey, the primary consideration being whether P-wave or S-wave velocities are to be determined. The source should be rich in the type of energy required, that is, to produce good P-wave data, the energy source must transmit adequate energy to the medium in compression or volume change. Impulsive sources, such as explosives, hammers, or air guns, are all acceptable P-wave generators. To produce an identifiable S wave, the source should transmit energy to the ground with a particle motion perpendicular or transverse to the axis of the survey. Impulse or vibratory S-wave sources are acceptable, but the source must be repeatable and, although not mandatory, reversible.

6.1.1.1 *Shear Beam*—A shear beam is a common form of an SH-wave energy source. The beam can be metal or wood, and may be encased at the ends and bottom with a steel plate. Strike plates may optionally be provided at the beam ends. The bottom plate may optionally have cleats to penetrate the ground and to prevent sliding when struck. A commonly utilized shear beam has approximate dimensions of 2.4 m (8 ft) long by 150 mm (6 in.) wide. The center of the shear beam is placed on the ground at a horizontal offset ranging from 1 to 3 m (3 to 10 ft) from the receiver borehole (or cone insertion point). This horizontal offset should be selected carefully since borehole disturbance, rod noise, and refraction through layers with significantly different properties may impact the test results. Larger horizontal offsets of 4 to 6 m (12 to 20 ft) for the seismic source may be necessary to avoid response effects due to surface or near-surface features. In this case the possibility of raypath refraction must be taken into account. The ends of the beam should be positioned equidistant from the receiver borehole. The shear beam is typically then loaded by the axle load of vehicle wheels or the leveling jacks of the cone rig. The

² For referenced ASTM standards, visit the ASTM website, www.astm.org, or contact ASTM Customer Service at service@astm.org. For *Annual Book of ASTM Standards* volume information, refer to the standard's Document Summary page on the ASTM website.

ground should be level enough to provide good continuous contact along the whole length of the beam to ensure good coupling between the beam and the ground. Beam-to-ground coupling should be accomplished by scraping the ground level to a smooth, intact surface. Backfilling to create a flat spot will not provide good beam-ground coupling and should be avoided. The shear beam is typically struck on a strike plate at one end using a nominal 1- to 15-kg hammer to produce a seismic wave train. Striking the other end will create a seismic wave train that has the opposite polarity relative to the wave train produced at the first end. Fig. 1 shows a diagram of the typical shear beam configuration that will produce SH-wave trains. Fig. 2 shows an example of an impulse seismic source wave train that contains both P- and S-wave components. Although the shear beam of dimensions 2.4 m (8 ft) long by 150 mm (6 in.) wide is commonly utilized, it may be desirable to implement beams of shorter length so that SH-source more closely approximates a “point source” for tests less than 20 m (60 ft) in depth. The “point source” SH-wave beam allows for the accurate specification of the source Cartesian location (x, y, and z coordinates) which is required for the subsequent interval velocity calculation. For example, if a large SH-hammer beam is utilized, it becomes difficult to specify the exact location of the seismic source. In addition, it is preferable to initially excite a small area if complex stratigraphy exist and shorter SH-hammer beams mitigate problems arising from poor beam-ground coupling.

6.1.2 *Receivers*—In the downhole seismic test, the seismic receivers are installed vertically with depth within a borehole

or as part of the instrumentation in a cone penetrometer probe. The receivers intended for use in the downhole test shall be transducers having appropriate frequency and sensitivity characteristics to determine the seismic wave train arrival. Typical transducer examples include geophones, which measure particle velocity, and accelerometers, which measure particle acceleration. Both geophones and accelerometers are acceptable for downhole seismic testing. High precision, low noise (operational amplifier integrated into sensor) accelerometers are generally more accurate due to their desirable transient response times (that is, delay, rise and peak times (10)) and high bandwidths compared to geophones. Sensors with fast transient response times are advantageous when carrying out downhole seismic testing within hard rock stratigraphy and high energy ambient noise environments. The frequency response of the transducer should not vary more than 5 % over a range of frequencies from 0.5 to 2 times the predominant frequency of the site-specific S-wave train. The geophones should not be heavily damped to minimize spectral smearing. The receiver section should be housed in a single container (cylindrical shape preferred) so that multiple axis sensors (transducers) are located within 10 cm (4 in.) of each other. Provision must be made for the container to be held in firm contact with the sidewall of the borehole. Examples of acceptable methods include: air bladder, wedge, stiff spring, or mechanical expander. Using a wedge to hold the sensor in place can result in erroneous data if the sensor is supported at the bottom. If a wedge is used, it should be positioned near the center of the receiver container mass. The receiver packages

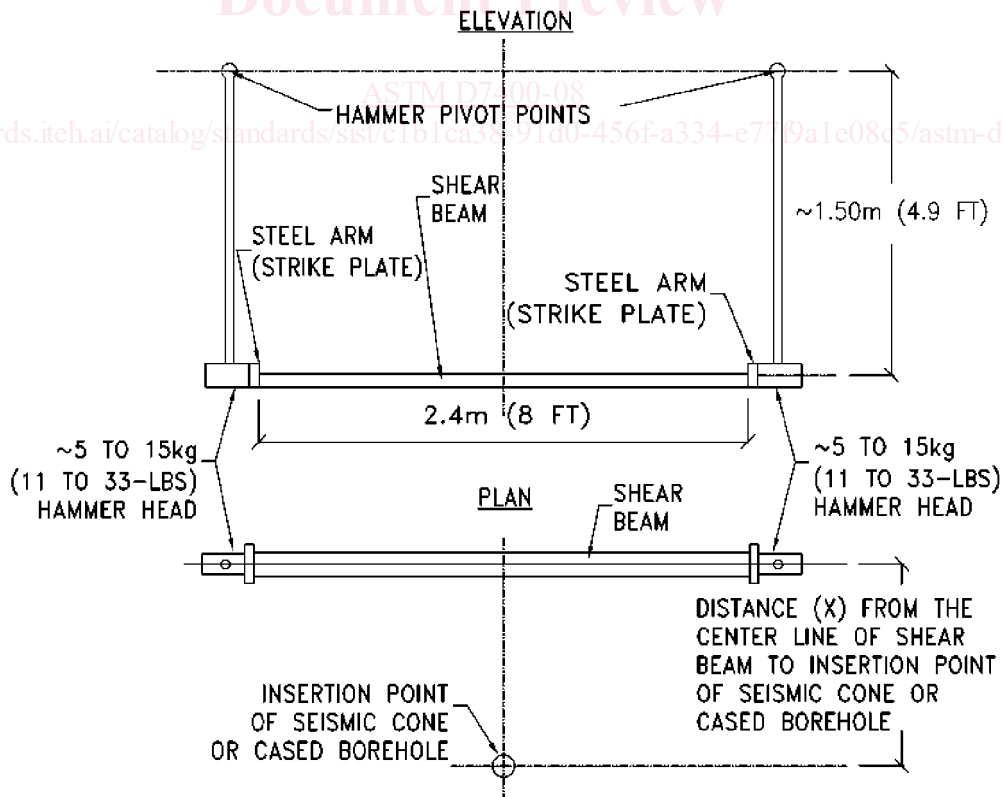

FIG. 1 Typical Downhole Shear Wave Source (Produces SH- Wave Train)

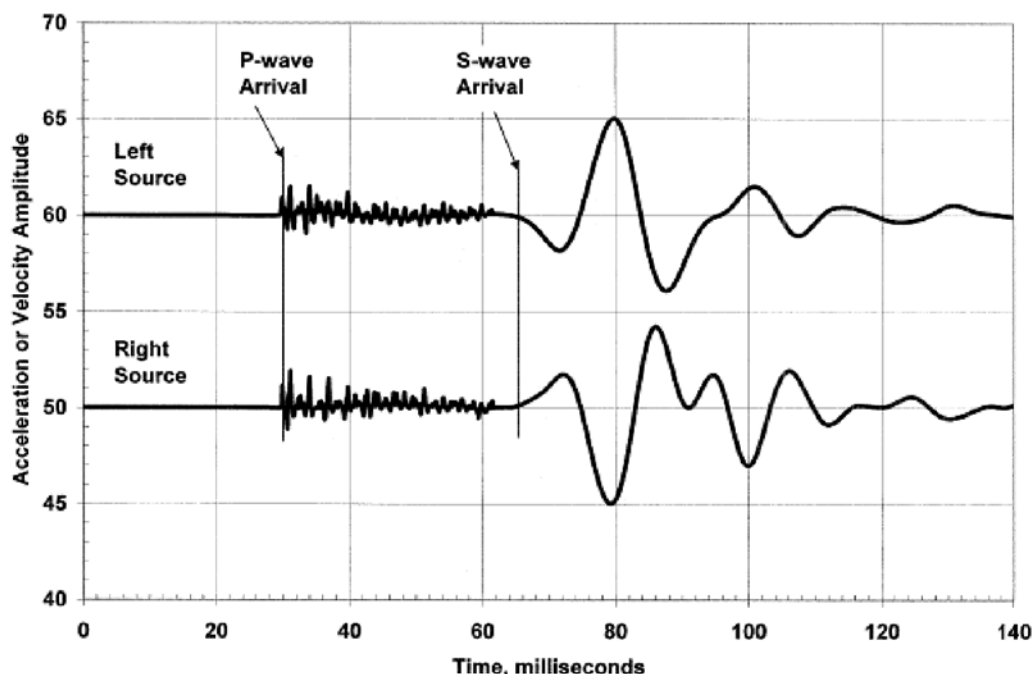

FIG. 2 Impulse Seismic Source (Produces P- and S-Wave Trains)

can also be grouted within the borehole (permanent array). When using the instrumented cone penetrometer probe, there is no borehole since the container is pushed directly through the soil so there is always firm contact. The diameter of the cone penetrometer at the location of the seismic instrumentation package (transducers) should be greater than that of the sections immediately below the instrumentation package to promote good coupling between the instrument and the surrounding soil.

6.1.2.1 Preferred Method— Each receiving unit will consist of at least three transducers combined orthogonally to form a triaxial array, that is, one vertical and two horizontal transducers mounted at right angles, one to the other. Two receiving units should be available for deployment, either as separate units operating independently or separated vertically in the same container.

6.1.2.2 Optional Method— A single uniaxial or biaxial receiver(s) may be used. Care should be taken to make sure the transducer is oriented in the direction most nearly parallel to the direction of the source for S-waves or radially for P-waves.

6.1.3 Recording System— The system shall consist of separate recording channels, one for each transducer being recorded, having identical phase characteristics and adjustable gain control. Appropriate anti-alias filtering should be applied to the sensor signals prior to analog-to-digital conversion. Only digital signal filtering will be acceptable for seismic signal enhancement. Analog filtering, active or passive, will not be acceptable because of inherent phase delays. Timing accuracy shall be demonstrated both immediately prior to and immediately after the conduct of the downhole test. Demonstrate accuracy by inducing and recording on the receiver channels an oscillating signal of 1000 Hz derived from a quartz-controlled oscillator, or a certified laboratory calibration obtained within the time frame recommended by the instrument manufacturer.

As an optional method, the true zero time should be determined by (1) a simultaneous display of the triggering mechanism along with at least one receiver, or (2) a laboratory calibration of the triggering mechanism which will determine the lapsed time between the trigger closure and development of that voltage required to initiate the sweep on an oscilloscope or seismograph. The triggering mechanism should be repeatable and accurate to <1 % of the approximate relative arrival time. For example, if it is assumed that there will be a maximum 400 ms interval velocity over a 1 m increment with a corresponding relative arrival time of 2.5 ms, then a triggering mechanism resolution and accuracy of 0.025 ms is required. Alternatively, timing accuracy may be demonstrated with an annual calibration by an accredited calibration agency. Permanent records of the seismic events should be made, or if digital seismographs are used with no permanent hard copy print records available on site, data should be recorded on suitable digital media and copied to a second digital storage device for backup before leaving the site.

7. Procedure

7.1 Borehole Preparation:

7.1.1 Preferred—The preferred method for preparing a borehole for downhole testing incorporates one borehole as illustrated in Fig. 3. A dry test hole is preferred to avoid signal noise caused by waves transmitted through the water column in a water-filled test hole.

7.1.1.1 Drill the borehole, with minimum sidewall disturbance, to a diameter not exceeding 175 mm (7.0 in.). After the drilling is completed, case the boring with 50 to 100 mm (2 to 4 in.) inside diameter PVC pipe or aluminum casing, taking into consideration the size of the downhole receivers. Before inserting the casing, close the bottom of the pipe with a cap

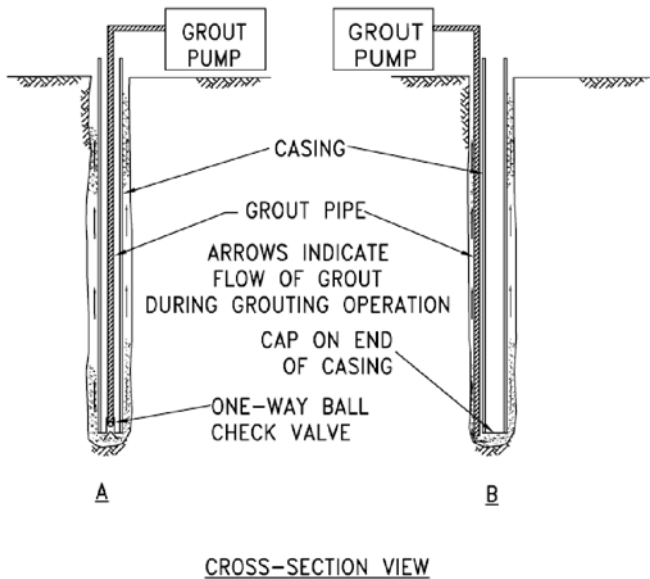

FIG. 3 Acceptable Grouting Techniques Schematic

which has a one-way ball-check valve capable of accommodating a 38 mm (1.5 in.) outside diameter grout pipe. Center the casing with spacers and insert it into the bottom of the borehole. Grout the casing in place by (1) inserting a 38 mm (1.5 in.) PVC pipe through the center of the casing, contacting the one-way valve fixed to the end cap (Fig. 3 side A), or (2) by a small diameter grout tube inserted to the bottom of the borehole between the casing and the borehole sidewall (Fig. 3 side B). Another acceptable method would be to fill the borehole with grout which would be displaced by end-capped fluid-filled casing. The grout mixture should be formulated to approximate closely the density of the surrounding in situ material after solidification. That portion of the boring that penetrates rock should be grouted with a conventional portland cement which will harden to a density of about 2.20 mg/m^3 (140 lb/ft^3). That portion of the boring in contact with soils, sands, or gravels should be grouted with a mixture simulating the average density of the medium (about 1.80 to 1.90 mg/m^3 (110 to 120 lb/ft^3)) by premixing 450 g (1 lb) of bentonite and 450 g (1 lb) of portland cement to 2.80 kg (6.25 lb) of water. Anchor the casing and pump the grout using a conventional, circulating pump capable of moving the grout through the grout pipe to the bottom of the casing upward from the bottom of the borehole (Fig. 3). Using this procedure, the annular space between the sidewall of the borehole and the casing will be filled from bottom to top in a uniform fashion displacing mud and debris with minimum sidewall disturbance. Keep the casing anchored and allow the grout to set before using the boreholes for downhole testing. If shrinkage occurs near the mouth of the borehole, additional grout should be added until the annular space is filled flush with the ground surface (4).

7.1.2 Optional—If the scope or intended use of a particular project does not warrant the time and expense which would be incurred by the preferred method, or if the specific project such as an investigation beneath a relatively small machine foundation is undertaken, this optional method may be used.

7.1.2.1 Borings may be used either with or without casing; however, if casing is used, grout should be injected between the casing and sidewall of the borehole to ensure good contact in the manner described in 7.1.1.1. Backfilling the annulus between the borehole and the casing with other suitable backfill material may be used but care should be taken to avoid bridging and resulting loss of coupling between the casing and the soil or rock.

7.2 Seismic Cone Penetration Deployment :

7.2.1 At the start of the cone penetration test, the body of the cone penetrometer should be rotated until the axis of the transducer is parallel to the long axis of the shear beam if a uniaxial configuration is implemented. If a biaxial (X and Y components) or triaxial sensor configuration (X, Y and Z components) is utilized, one of the horizontal components should be aligned parallel to the shear beam in order to maximize the SH-wave amplitude in one component direction. The cone penetrometer is pushed into the ground to the desired downhole test depth, monitoring the CPT instruments and inclination of the cone assembly during the push. The depth to the receivers should be recorded. Care should be exercised to avoid rotation of the sensors during the addition of subsequent rods.

7.3 Downhole Test:

7.3.1 Begin the downhole test by preparing the energy source at its desired location. Place the receiver(s) at the top of the receiver hole. If possible, orient the receiver unit bodies so that the axis of a horizontal transducer is parallel to the long axis of the shear beam. If two separate units are being used, lower or push the lower unit at a depth of 1.0 to 1.5 m (3 to 5 ft) below the upper unit which should be positioned so the transducers are essentially at the ground surface. Clamp the receiver(s) firmly into place. Check the recording equipment and verify timing. Monitor the output of the receivers without activating the energy source to evaluate the ambient seismic noise in the ground and to establish a basis for filtering the noise, if necessary.

7.3.2 Activate the energy source and display the receiver(s) trace(s) on the recording device. If both P- and S-wave sources are being used, tests should be conducted separately for better results. Adjust the amplifier gain and recording time such that the P-wave train or S-wave train, or both, are displayed in their entirety. If the recorder allows the test to be repeated and superimposed (stacked) on the earlier test, repeat the test 3 to 5 times (or more if needed to obtain a consistent and reproducible record) to improve the signal-to-noise ratio. Record, store the wave train digitally and print a hard copy of the wave train for all receivers. If the reversible polarity shear beam energy source is used, the trigger should be reset and the energy source activated at the opposite end of the beam and 7.3.2 is repeated.

7.3.2.1 Best results will be obtained by performing two separate tests: one optimized for P-wave recovery (fastest sweep/recorder rate, higher gain settings), and the second for S-wave recovery (slower sweep/recorder rate, lower gain settings). If enhancement equipment is being used, repeatedly

activate the energy source until optimum results are displayed. Do not over-range memory circuitry. A clipped signal is unacceptable.

7.3.3 Perform the next test by lowering the receiver(s) to a depth dictated by known stratification, but typically no greater than 1.5 m (5.0 ft), and no less than 0.5 m (2 ft) from the previous test locations in the borings and repeat the above procedure. Optionally, other test depth intervals may be used depending on the purpose and the site conditions. For tests performed in hard rock below 30 m (100 ft) depth below ground surface, the test interval may be increased to 3 m (10 ft). Continue with succeeding tests until the maximum borehole depth has been reached. As an alternate, tests can be conducted from the bottom of hole while retrieving the receiver. It may be advantageous to leave the receiver clamped during the entire retrieval process, stopping the retrieval at each test interval depth to conduct the test for that depth. This will reduce the rotation of the receiver and the time to clamp and unclamp at each depth. Fig. 4 shows a schematic of the cased borehole deployment. Figs. 5 and 6 show a schematic of the seismic cone deployment configuration.

8. Data Reduction and Interpretation

8.1 *Straight-Line Slant Distance* —Average seismic wave velocities will be computed by determining the straight-line distance, L , from the source to receivers. To do this, the following data are needed:

- E_S = elevation of the ground surface in contact with the energy source at the center of the energy source,
- E_G = elevation of the top of the geophone hole,
- D_G = depth of the geophone receiver,
- X = horizontal distance between the center of the energy source and the geophone borehole/sounding,

8.1.1 The following equation determines the straight-line slant distance, L_R , from source to geophone using the data of 8.1:

$$L_R = [(E_S - E_G + D_G)^2 + X^2]^{0.5} \quad (1)$$

The apparent average velocity is equal to L_R divided by the travel time.

8.2 Wave Train Identification:

8.2.1 Identify the P-wave train arrival time as the first departure of the static horizontal receiver trace after time $T = 0$. A P-wave arrival may not be apparent if an SH-rich energy source is used. Also, the P-wave train arrival may not necessarily be the first departure of the static horizontal receiver after time $T = 0$. This may be “rod noise” or other seismic wave phenomena. It may be preferable to initially estimate a velocity trend line from a vertical seismic profile (VSP) to assure that the correct responses have been identified. In general terms, the magnitude of the P- and S-wave responses will be dependent upon the source-sensor geometry and type of source implemented as illustrated in Fig. 7 (9). If both wave trains (P and S) are displayed simultaneously on the records, the S wave will be typically identified on the seismic signature by the following characteristics:

8.2.1.1 A sudden increase in amplitude, and

8.2.1.2 An abrupt change in frequency coinciding with the amplitude change.

8.2.1.3 If a reversible polarity seismic source is used, the S wave arrival will be determined as that point meeting the criteria of 8.2.1.1 and 8.2.1.2 and where a 180° polarity change is noted to have occurred.

8.2.2 The above characteristics are displayed in Fig. 2. Determine the arrival time for the P wave or S wave directly from the record as the lapsed time between time zero (activation of the seismic source) and the arrival of the respective wave trains at each of the receiver depths. If a polarized S-wave vibratory source is used, the arrival time of the S wave can be determined from the time lapsed between the start up of the seismic source monitor geophone and the first arrival of a seismic signal bearing the same characteristic frequency.

8.3 Data Tabulation:

8.3.1 The wave arrival time must be interpreted from the recorded wave trains for a given test depth. If reversible polarity shear waves are used, the shear wave arrival from one hammer strike event can usually be seen clearly as a mirror image of the hammer strike(s) at the opposite event as shown in Fig. 8. Up to three separate travel times are observed in the field and recorded are as follows:

8.3.1.1 Source to Receiver 1, T_{R1} ,

8.3.1.2 Source to Receiver 2 (if used), T_{R2} , and

8.3.1.3 Time difference between Receivers 1 and 2 (if both are used), T_{R2-R1} .

8.3.2 Tabulate the data in a manner similar to that shown in Fig. 9.

8.4 Data Reduction:

8.4.1 In materials where abrupt changes in density or elasticity occur, the ray travel path of the wave might not be a straight line (6). In such cases, Snell’s law of refraction must be used. Downhole tests conducted to deeper depths (below 20 m (60 ft)) are not heavily influenced by Snell’s Law. For sites where the upper material (10 m (30 ft)) is to be removed, it is not necessary to use Snell’s Law to perform these calculations.

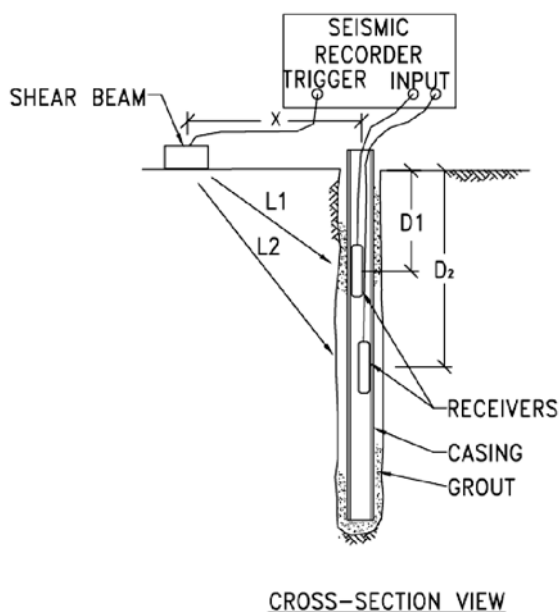

CROSS-SECTION VIEW

FIG. 4 Downhole Seismic Test in Cased Boring Schematic