



Designation: D2300 – 08

Standard Test Method for Gassing of Electrical Insulating Liquids Under Electrical Stress and Ionization (Modified Pirelli Method)¹

This standard is issued under the fixed designation D2300; the number immediately following the designation indicates the year of original adoption or, in the case of revision, the year of last revision. A number in parentheses indicates the year of last reapproval. A superscript epsilon (ϵ) indicates an editorial change since the last revision or reapproval.

1. Scope

1.1 This test method measures the rate at which gas is evolved or absorbed by insulating liquids when subjected to electrical stress of sufficient intensity to cause ionization in cells having specific geometries.

1.2 This test method is not concerned with bubbles arising from supersaturation of the insulating liquid.

1.3 *This standard does not purport to address all of the safety concerns, if any, associated with its use. It is the responsibility of whoever uses this standard to consult and establish appropriate safety and health practices and determine the applicability of regulatory limitations prior to use.* For specific precautions see 5.1.4 and 8.4.

2. Referenced Documents

2.1 *ASTM Standards:*²

D924 Test Method for Dissipation Factor (or Power Factor) and Relative Permittivity (Dielectric Constant) of Electrical Insulating Liquids

3. Summary of Test Method³

3.1 After being saturated with a gas (usually hydrogen), the insulating liquid is subjected to a radial electrical stress. The gas space above the insulating liquid film is ionized due to the electrical stresses and therefore the insulating liquid surface at the insulating liquid-gas interface is subjected to ionic bombardment. The evolving or absorbing of gas is calculated in

volume per unit of time from changes in pressure with time from two specimens run on the same sample.

3.2 This test method indicates whether insulating liquids are gas absorbing or gas evolving under the test conditions.

4. Significance and Use

4.1 For certain applications when insulating liquid is stressed at high voltage gradients, it is desirable to be able to determine the rate of gas evolution or gas absorption under specified test conditions. At present time correlation of such test results with equipment performance is limited.

4.2 In this test method, hydrogen (along with low molecular weight hydrocarbons) is generated by ionic bombardment of some insulating liquid molecules and absorbed by chemical reaction with other insulating liquid molecules. The value reported is the net effect of these two competing reactions. The aromatic molecules or unsaturated portions of molecules present in insulating liquids are largely responsible for the hydrogen-absorbing reactions. Both molecule type, as well as concentration, affects the gassing tendency result. Saturated molecules tend to be gas evolving. The relation between aromaticity and quantity of unsaturates of the insulating liquid and gassing tendency is an indirect one and cannot be used for a quantitative assessment of either in the insulating liquid.

4.3 This test method measures the tendency of insulating liquids to absorb or evolve gas under conditions of electrical stress and ionization based on the reaction with hydrogen, the predominant gas in the partial discharge. For the test conditions, the activating gas hydrogen, in contrast to other gases, for example, nitrogen, enhances the discrimination of differences in the absorption-evolution patterns exhibited by the insulating liquids. Insulating liquids shown to have gas-absorbing (H_2) characteristics in the test have been used to advantage in reducing equipment failures, particularly cables and capacitors. However, the advantage of such insulating liquids in transformers is not well defined and there has been no quantitative relationship established between the gassing tendency as indicated by this test method and the operating performance of the equipment. This test method is not concerned with bubble evolution, which may arise from physical processes associated with super-saturation of gases in oil or water vapor bubbles evolving from wet insulation.

¹ This test method is under the jurisdiction of ASTM Committee D27 on Electrical Insulating Liquids and Gases and is the direct responsibility of Subcommittee D27.05 on Electrical Test.

Current edition approved June 1, 2008. Published July 2008. Originally approved in 1968. Last previous edition approved in 2000 as D2300–00. DOI: 10.1520/D2300-08.

² For referenced ASTM standards, visit the ASTM website, www.astm.org, or contact ASTM Customer Service at service@astm.org. For *Annual Book of ASTM Standards* volume information, refer to the standard's Document Summary page on the ASTM website.

³ The original Pirelli method is described by Guisepppe Palandri and Ugo Pellagatti in the paper, "Gli Oli Isolanti per Cavi Elettrici" (Insulating Oils for Electric Cables), *Elettrotecnica* (Milan) Jan. 8, 1955. Translation of this paper is contained in "Minutes of the Meeting of the Insulated Conductors Committee of the American Institute of Electrical Engineers," Nov. 15 and 16, 1955.

5. Apparatus

5.1 The apparatus for making gassing tests where the insulating liquid is saturated in the same cell that is used thereafter to electrically stress the insulating liquid is shown in Fig. 1. The apparatus consists of the following:

5.1.1 *Gassing Cell and Buret Assembly*, as shown in Fig. 1, with dimensions as given in Fig. 2. The gassing cell consists of the following two components:

5.1.1.1 Cell made of borosilicate glass with the part under stress constructed of 16 mm inside diameter and 18 mm outside diameter truebore tubing. This cell has an outer (ground) electrode of painted or plated silver with a vertical slit for observing the insulating liquid level, and a metal conductor band for ground connection.

5.1.1.2 *Hollow High-Voltage Electrode* made of 10 ± 0.1 -mm outside diameter center-less-ground and polished No. 304 stainless steel seamless tubing and containing an 18-gage stainless steel capillary tubing as a gas passage. The electrode shall be supported and centered by a precision-machined 24/40 recessed TFE-fluorocarbon plug. A $\frac{1}{8}$ -in. needle valve (*E*) with gas inlet is on top of the electrode.

5.1.2 *Gas Buret* (Fig. 1) made of 7-mm outside diameter borosilicate glass tubing with an etched scale, tapered glass joint (*G*) for connecting to the gassing cell, a bypass stopcock (*D*), and three glass bulbs, (*A*, *B*, and *C*).

5.1.3 *Oil Bath* with thermostatic control to maintain the bath at test temperature $\pm 0.5^\circ\text{C}$. The bath shall be equipped with a stirrer, a heating arrangement capable of maintaining the necessary temperature control, a suitable support for the gassing test cell assembly, and a thermometer graduated in 0.1°C divisions. As the test is temperature sensitive, it is important that the calibration is traceable to a standard, such as NIST.

5.1.4 *Transparent Safety Shield* to protect the operator from contact with high voltage.

5.1.5 *High-Voltage Transformer*, providing a test voltage having a frequency in the range of 45 to 65 Hz. The

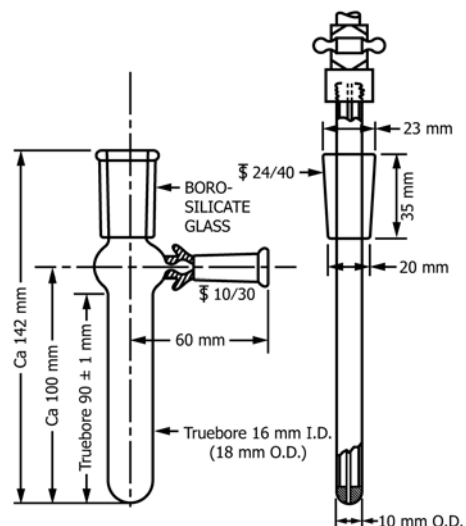

FIG. 2 Detailed Dimensions of the Glass Cell and the Inner (High-Voltage) Electrode

transformer and its controlling equipment shall be of such size and design that with the test specimen in the circuit, the voltage wave shape shall approximate a sinoid with both half cycles closely alike. The ratio of peak-to-rms values should be equal to the square root of two within $\pm 5\%$ while maintaining $10 \text{ RV} \pm 2\%$.

6. Reagents and Materials

6.1 *Hydrogen*, oxygen-free. See Note 1.

6.2 *Dibutyl Phthalate*, reagent grade.

6.3 *2-Propanol*, reagent grade.

6.4 Low vapor pressure grease, such as high vacuum silicone grease.

6.5 Unless otherwise indicated, it is intended that all reagents shall conform to the Committee on Analytical Reagents of the American Chemical Society.

NOTE 1—Hydrogen normally is the saturating gas but other gases, such as nitrogen, carbon dioxide, argon, or air may be used.

7. Preparation of Apparatus

7.1 Clean the glass cell by first rinsing it inside and outside with a suitable hydrocarbon solvent such as heptane or other solvent suitable for the dielectric liquid test tested. Then fill the cell with the hydrocarbon solvent and scrub to remove waxy deposits from previous tests. Clean the tapered joint, taking care that none of the grease enters the cell. Again rinse with hydrocarbon solvent and blow dry with clean compressed air. Check the silver electrode and repair if necessary.

7.2 Clean the hollow electrode by blowing a suitable hydrocarbon solvent through the capillary tube with compressed air, rinsing the insulating liquid off the entire electrode with a suitable hydrocarbon solvent, such as heptane, and wiping off any waxy deposit with tissue paper. Polish the surface with a 2-propanol soaked towel. If there are visible marks on the stainless steel shaft of the electrode, they should be polished with a suitable device, such as a buffing wheel, wiping off the

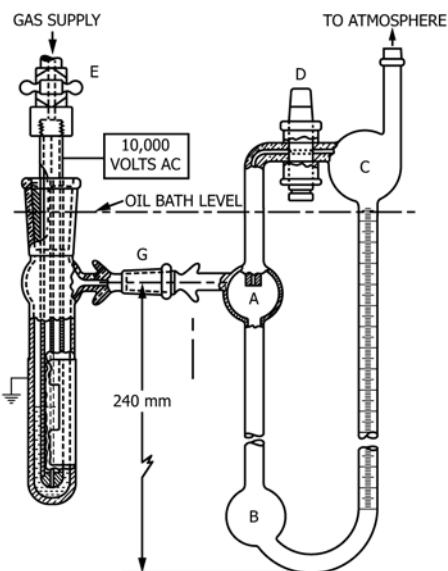

FIG. 1 Schematic Diagram of Cell and Manometer Assembly