

Third edition
2012-10-01

Corrected version
2012-11-15

Safety of toys —

Part 1:

**Safety aspects related to mechanical and
physical properties**

Sécurité des jouets

*Partie 1: Aspects de sécurité relatifs aux propriétés mécaniques et
physiques*

(standards.iteh.ai)

ISO 8124-1:2012

<https://standards.iteh.ai/catalog/standards/sist/9095ce71-3612-43e3-af87-e64743b3c1f2/iso-8124-1-2012>



Reference number
ISO 8124-1:2012(E)

© ISO 2012

iTeh STANDARD PREVIEW (standards.iteh.ai)

ISO 8124-1:2012

<https://standards.iteh.ai/catalog/standards/sist/9095ce71-3612-43e3-af87-e64743b3c1f2/iso-8124-1-2012>



COPYRIGHT PROTECTED DOCUMENT

© ISO 2012

All rights reserved. Unless otherwise specified, no part of this publication may be reproduced or utilized in any form or by any means, electronic or mechanical, including photocopying and microfilm, without permission in writing from either ISO at the address below or ISO's member body in the country of the requester.

ISO copyright office
Case postale 56 • CH-1211 Geneva 20
Tel. + 41 22 749 01 11
Fax + 41 22 749 09 47
E-mail copyright@iso.org
Web www.iso.org

Published in Switzerland

Contents

Page

Foreword	v
Introduction	vi
1 Scope	1
2 Normative references	3
3 Terms and definitions	3
4 Requirements	12
4.1 Normal use	12
4.2 Reasonably foreseeable abuse	12
4.3 Material	12
4.4 Small parts	13
4.5 Shape, size and strength of certain toys	13
4.6 Edges	18
4.7 Points	19
4.8 Projections	20
4.9 Metal wires and rods	20
4.10 Plastic film or plastic bags in packaging and in toys	20
4.11 Cords and elastics	21
4.12 Folding mechanisms	22
4.13 Holes, clearances and accessibility of mechanisms	24
4.14 Springs	26
4.15 Stability and overload requirements	26
4.16 Enclosures	27
4.17 Simulated protective equipment, such as helmets, hats and goggles	28
4.18 Projectile toys	29
4.19 Aquatic toys	30
4.20 Braking	30
4.21 Toy bicycles	31
4.22 Speed limitation of electrically driven ride-on toys	32
4.23 Toys containing a heat source	32
4.24 Liquid-filled toys	33
4.25 Mouth-actuated toys	33
4.26 Toy roller skates, toy inline skates and toy skateboards	33
4.27 Percussion caps	33
4.28 Acoustic requirements	33
4.29 Toy scooters	34
4.30 Magnets and magnetic components	36
5 Test methods	37
5.1 General	37
5.2 Small parts test	37
5.3 Test for shape and size of certain toys	38
5.4 Small balls test	39
5.5 Test for pompoms	40
5.6 Test for pre-school play figures	40
5.7 Accessibility of a part or component	40
5.8 Sharp-edge test	42
5.9 Sharp-point test	43
5.10 Determination of thickness of plastic film and sheeting	46
5.11 Test for cords	46
5.12 Stability and overload tests	47
5.13 Test for closures and toy chest lids	49
5.14 Impact test for toys that cover the face	49
5.15 Kinetic energy of projectiles, bows and arrows	49
5.16 Free-wheeling facility and brake performance test	51

5.17	Determination of speed of electrically driven ride-on toys	52
5.18	Determination of temperature increases	52
5.19	Leakage of liquid-filled toys	52
5.20	Durability of mouth-actuated toys	52
5.21	Expanding materials	53
5.22	Folding or sliding mechanisms	53
5.23	Washable toys	54
5.24	Reasonably foreseeable abuse tests	54
5.25	Determination of sound pressure levels	59
5.26	Static strength for toy scooters	64
5.27	Dynamic strength for toy scooters	65
5.28	Brake performance for toy scooters	67
5.29	Strength of toy scooter steering tubes	68
5.30	Resistance to separation of handlebar	69
5.31	Tension test for magnets	70
5.32	Magnetic flux index	71
5.33	Impact test for magnets	72
5.34	Soaking test for magnets	72
Annex A (informative) Age-grading guidelines		73
Annex B (informative) Safety-labelling guidelines and manufacturer's markings		76
Annex C (informative) Design guidelines for toys attached to cribs or playpens		82
Annex D (informative) Toy gun marking		83
Annex E (informative) Rationale		84
Bibliography		97

iTeH STANDARD PREVIEW
(standards.iteh.ai)

ISO 8124-1:2012
<https://standards.iteh.ai/catalog/standards/sist/9095ce71-3612-43e3-af87-e64743b3c1f2/iso-8124-1-2012>

Foreword

ISO (the International Organization for Standardization) is a worldwide federation of national standards bodies (ISO member bodies). The work of preparing International Standards is normally carried out through ISO technical committees. Each member body interested in a subject for which a technical committee has been established has the right to be represented on that committee. International organizations, governmental and non-governmental, in liaison with ISO, also take part in the work. ISO collaborates closely with the International Electrotechnical Commission (IEC) on all matters of electrotechnical standardization.

International Standards are drafted in accordance with the rules given in the ISO/IEC Directives, Part 2.

The main task of technical committees is to prepare International Standards. Draft International Standards adopted by the technical committees are circulated to the member bodies for voting. Publication as an International Standard requires approval by at least 75 % of the member bodies casting a vote.

Attention is drawn to the possibility that some of the elements of this document may be the subject of patent rights. ISO shall not be held responsible for identifying any or all such patent rights.

ISO 8124-1 was prepared by Technical Committee ISO/TC 181, *Safety of toys*.

This third edition cancels and replaces the second edition (ISO 8124-1:2009), of which it constitutes a minor revision. It also incorporates the amendments ISO 8124-1:2009/Amd.1:2011 and ISO 8124-1:2009/Amd.2:2012.

ISO 8124 consists of the following parts, under the general title *Safety of toys*:

- *Part 1: Safety aspects related to mechanical and physical properties*
- *Part 2: Flammability*
- *Part 3: Migration of certain elements*
- *Part 4: Swings, slides and similar activity toys for indoor and outdoor family domestic use*

The following parts are under preparation:

- *Part 5: Determination of total concentration of certain elements in toys*
- *Part 6: Toys and children's products — Determination of phthalate plasticizers in polyvinyl chloride plastics*

This corrected version of ISO 8124-1:2012 incorporates the following correction:

- in 4.11.7, “108 Ω/cm” has been replaced by “10⁸ Ω/cm”.

Introduction

This part of ISO 8124 is largely based upon existing standards in the European Union (EN 71-1 and in the United States of America (ASTM F963).

However, it should not be construed that a toy manufactured in compliance with this part of ISO 8124 will be in full compliance with relevant national toy safety requirements in the market where the product is intended to be distributed. The user of this part of ISO 8124 is therefore advised to be aware of relevant national requirements.

Compliance with the requirements of this part of ISO 8124 will minimize potential hazards associated with toys resulting from their use in their intended play modes (normal use) as well as unintended play modes (reasonably foreseeable abuse).

This part of ISO 8124 will not, nor is it intended to, eliminate parental responsibility in the appropriate selection of toys. In addition, this part of ISO 8124 will not eliminate the need for parental supervision in situations where children of various ages may have access to the same toy(s).

Although Annexes A, B, C, D and E are for information purposes only, they are crucial for the correct interpretation of this part of ISO 8124.

The safety of electric toys is described in IEC 62115.

When age indications are required for safety labelling purposes, they may be given in either months or years.

iTeh STANDARD PREVIEW (standards.iteh.ai)

ISO 8124-1:2012

<https://standards.iteh.ai/catalog/standards/sist/9095ce71-3612-43e3-af87-e64743b3c1f2/iso-8124-1-2012>

Safety of toys —

Part 1: Safety aspects related to mechanical and physical properties

1 Scope

The requirements in this part of ISO 8124 apply to all toys, i.e. any product or material designed or clearly intended for use in play by children under 14 years of age. They are applicable to a toy as it is initially received by the consumer and, in addition, they apply after a toy is subjected to reasonably foreseeable conditions of normal use and abuse unless specifically noted otherwise.

The requirements of this part of ISO 8124 specify acceptable criteria for structural characteristics of toys, such as shape, size, contour, spacing (e.g. rattles, small parts, sharp points and edges, and hinge-line clearances) as well as acceptable criteria for properties peculiar to certain categories of toy (e.g. maximum kinetic energy values for non-resilient-tipped projectiles and minimum tip angles for certain ride-on toys).

This part of ISO 8124 specifies requirements and test methods for toys intended for use by children in various age groups from birth to 14 years. The requirements vary according to the age group for which a particular toy is intended. The requirements for a particular age group reflect the nature of the hazards and the expected mental and/or physical abilities of a child to cope with them.

This part of ISO 8124 also requires that appropriate warnings and/or instructions for use be given on certain toys or their packaging. Due to linguistic problems which may occur in different countries, the wording of these warnings and instructions is not specified but given as general information in Annex B. It should be noted that different legal requirements exist in many countries with regard to such marking.

This part of ISO 8124 does not purport to cover or include every conceivable potential hazard of a particular toy or toy category. Except for labelling requirements indicating the functional hazards and the age range for which the toy is intended, this part of ISO 8124 has no requirements for those characteristics of toys which represent an inherent and recognized hazard which is integral to the function of the toy.

EXAMPLE 1 An example of such a hazard is the sharp point necessary for the proper function of a needle. The needle is a hazard which is well understood by the purchaser of a toy sewing kit, and the functional sharp-point hazard is communicated to the user as part of the normal educational process of learning to sew as well as at the point of purchase by means of cautionary labelling on the product's packaging.

EXAMPLE 2 As a further example, a two-wheeled toy scooter has inherent and recognized hazards associated with its use (e.g. instability during use, especially while learning). The potential hazards associated with its structural characteristics (sharp edges, pinch hazards, etc.) will be minimized by compliance with the requirements of this part of ISO 8124.

Products not included within the scope of this part of ISO 8124 are:

- a) bicycles, except for those considered to be toys, i.e. those having a maximum saddle height of 435 mm (see E.1);
- b) slingshots;

NOTE "Slingshots" are also known as "catapults" and are usually held in the hand; examples are given in Figure 1. Toy versions of medieval catapults and trebuchets are not exempt from this part of ISO 8124; an example is given in Figure 2.



Figure 1 — Examples of slingshots (not within the scope of this part of ISO 8124)



iTeh STANDARD PREVIEW

Figure 2 — Medieval toy catapult (within the scope of this part of ISO 8124)

- c) darts with metal points; <https://standards.iteh.ai/catalog/standards/sist/9095cc71-3612-43e3-af87-e64743b3c1f2/iso-8124-1-2012>
- d) home and public playground equipment; <https://standards.iteh.ai/catalog/standards/sist/9095cc71-3612-43e3-af87-e64743b3c1f2/iso-8124-1-2012>
- e) compressed air- and gas-operated guns and pistols (see E.1);
- f) kites (except for the electric resistance of their strings, which is included);
- g) model kits, hobby and craft items, in which the finished item is not primarily of play value;
- h) sporting goods and equipment, camping goods, athletic equipment, musical instruments and furniture; however, toys which are their counterparts are included.

It is recognized that there is often a fine distinction between, for example a musical instrument or a sporting item and its toy counterpart. The intention of the manufacturer or distributor, as well as normal use and reasonably foreseeable abuse, determines whether the item is a toy counterpart or not;
- i) models of aircraft, rockets, boats and land vehicles powered by combustion engines; however, toys which are their counterparts are included (see E.1);
- j) collectible products not intended for children under 14 years of age;
- k) holiday decorations that are primarily intended for ornamental purposes;
- l) aquatic equipment intended to be used in deep water, swimming-learning devices and flotation aids for children such as swim-seats and swim-aids;
- m) toys installed in public places (e.g. arcades and shopping centres);
- n) puzzles having more than 500 pieces or without a picture, for specialists;
- o) fireworks including percussion caps, except percussion caps specifically designed for toys;

- p) products containing heating elements intended for use under the supervision of an adult in a teaching context;
- q) steam engines;
- r) video toys that can be connected to a video screen and operated at a nominal voltage greater than 24 V;
- s) babies' pacifiers (dummies);
- t) faithful reproduction of firearms;
- u) electric ovens, irons or other functional products operated at a nominal voltage greater than 24 V;
- v) bows for archery with an overall relaxed length exceeding 120 cm;
- w) fashion jewellery for children (see E.1).

2 Normative references

The following referenced documents are indispensable for the application of this document. For dated references, only the edition cited applies. For undated references, the latest edition of the referenced document (including any amendments) applies.

ISO 868, *Plastics and ebonite — Determination of indentation hardness by means of a durometer (Shore hardness)*

ISO 3746:2010, *Acoustics — Determination of sound power levels of noise sources using sound pressure — Survey method using an enveloping measurement surface over a reflecting plane*

ISO 4287, *Geometrical Product Specifications (GPS) — Surface texture: Profile method — Terms, definitions and surface texture parameters*

ISO 6508-1, *Metallic materials — Rockwell hardness test — Part 1: Test method (scales A, B, C, D, E, F, G, H, K, N, T)*

ISO 11201, *Acoustics — Noise emitted by machinery and equipment — Measurement of emission sound pressure levels at a work station and at other specified positions — Engineering method in an essentially free field over a reflecting plane*

ISO 11202, *Acoustics — Noise emitted by machinery and equipment — Measurement of emission sound pressure levels at a work station and at other specified positions — Survey method in situ*

ISO 11204, *Acoustics — Noise emitted by machinery and equipment — Measurement of emission sound pressure levels at a work station and at other specified positions — Method requiring environmental corrections*

IEC 61672-1, *Electroacoustics — Sound level meters — Part 1: Specifications*

IEC 61672-2, *Electroacoustics — Sound level meters — Part 2: Pattern evaluation tests*

3 Terms and definitions

For the purposes of this document, the following terms and definitions apply.

NOTE The requirements in this part of ISO 8124 are applicable to certain age ranges. For interpretation of these age ranges, see E.42 (age-break terminology).

3.1

accessible

⟨part or component⟩ any area of the toy that can be contacted by any portion forward of the collar of the accessibility probe as described in 5.7

3.2 aquatic toy
article, whether inflatable or not, intended to bear the mass of a child and used as an instrument of play in shallow water

NOTE Bathroom toys and beach balls are not considered aquatic toys.

3.3 backing
material adhering to flexible plastic sheeting

3.4 ball
spherical, ovoid or ellipsoidal object, usually but not always designed or intended to be thrown, hit, kicked, rolled, dropped or bounced

NOTE 1 This definition includes balls attached to a toy or article by a string, elastic cord or similar tether and also any multi-sided object formed by connecting planes into, and any novelty item of, a generally spherical, ovoid or ellipsoidal shape designed or intended to be used as a ball.

NOTE 2 This definition does not include dice, or balls permanently enclosed inside pinball machines, mazes or similar outer containers. A ball is permanently enclosed if, when tested according to 5.24 (reasonably foreseeable abuse), it is not removed from the outer container.

3.5 battery-operated toy
toy having at least one function dependent on electricity and powered by batteries

3.6 burr
roughness caused by not cleanly severing or finishing the material

3.7 close-to-the-ear toy
toy that is intended to be used close to the ear, i.e. the sound-emitting part of such a toy is normally put against the ear of a child

EXAMPLES Toy cellphones or toy telephones that emit sounds from the handpiece.

3.8 collapse
sudden or unexpected folding of a structure

3.9 continuous sound
any steady-state sound or group of variable sounds greater than one second in duration

3.10 cord
length of slender, flexible material

EXAMPLE Monofilaments, woven and twisted cord, rope, plastic textile tapes, ribbon and those fibrous materials known as string.

NOTE Doll hair is not considered a cord.

3.11 crushing
injury to part of the body resulting from compression between surfaces

3.12**C-weighted peak sound pressure level** L_{pCpeak}

peak sound pressure level obtained when using standardized C-weighting

3.13**discharge mechanism**

inanimate system for releasing and propelling a projectile

3.14**driving mechanism**

assembly of linked parts or components (e.g. gears, belts and winding mechanisms), at least one of which moves, powered by a source (e.g. electrical or mechanical means) independent of a child

3.15**edge**

line, formed at the junction of two surfaces, whose length exceeds 2,0 mm

3.15.1**curled edge**

edge in which the portion of the sheet adjacent to the edge is bent into an arc and forms an angle of less than 90° with the base sheet

NOTE See Figure 3.

3.15.2**hemmed edge**

edge in which the portion of the sheet adjacent to the edge is folded back on the sheet itself through an angle of approximately 180°, so that the portion of the sheet adjacent to the edge is approximately parallel to the main sheet

NOTE See Figure 3.

3.15.3**rolled edge**

edge in which the portion of the sheet adjacent to the edge is bent into an arc and forms an angle between 90° and 120° with the main sheet

NOTE See Figure 3.

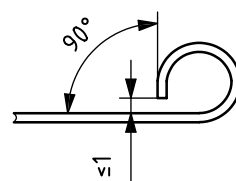
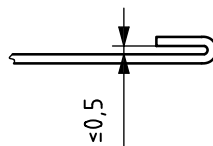
**a) Rolled edge****b) Hemmed (folded) edge**

Dimensions in millimetres

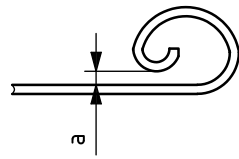

c) Curled edge

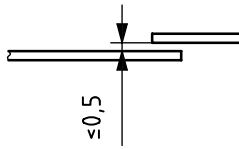

d) Typical lap joint

a No limit.

Figure 3 — Edges

3.16 equivalent sound pressure level

L_{pAeq}
level of a steady-state sound which, in a stated time period and at a stated location, has the same A-weighted sound energy as the time-varying sound

3.17 expanding material

material whose volume expands when exposed to water

iTeh STANDARD PREVIEW
(standards.iteh.ai)

3.18 explosive action

sudden release of energy characterized by the rapid expansion or bursting of a material

ISO 8124-1:2012

<https://standards.iteh.ai/catalog/standards/sist/9095cc71-3612-43e3-af87-647955222109-iso-8124-1-2012>

3.19 fastener

mechanical device which attaches two or more elements together

EXAMPLE Screws, rivets and staples.

3.20 feathering

beveling of an edge (or decrease in thickness moving toward the edge) caused during shearing or cutting of material

3.21 flash

excess material that escapes between the mating parts of a mould assembly

3.22 folding mechanism

hinged, pivoted, folding or sliding assembly which could crush, scissor, pinch or shear during operation

EXAMPLE Toy ironing boards, toy pushchairs.

3.23 functional magnet in electrical or electronic components of toys

any magnet necessary for the function of motors, relays, speakers and other electrical or electronic components in a toy where the magnetic properties are not part of the play pattern of the toy

3.24**functional toy**

toy which performs and is used in the same way as, and is often a scale model of, a certain product, appliance or installation intended for adults

EXAMPLE Stove with heating properties.

3.25**fuzz**

bits of fibrous-type material which can be readily removed from toys with a pile surface

3.26**glass**

hard, brittle, amorphous substance produced by fusion, usually consisting of mutually dissolved silica and silicates which also contain soda and lime

3.27**hand-held toy**

toy that is intended to be used or operated while being held in the hand

EXAMPLE Toy tools, small electronic games, stuffed animals, dolls, musical toys and cap-firing toys.

3.28**harm**

physical injury or damage to the health of people or damage to property or the environment

3.29**hazard**

potential source of harm

iTeh STANDARD PREVIEW
(standards.iteh.ai)

NOTE The term hazard can be qualified in order to define its origin or the nature of the expected harm (i.e. electric shock hazard, crushing hazard, cutting hazard, toxic hazard, fire hazard or drowning hazard).

3.30**hazardous projection**

projection that, because of its material or configuration or both, may present a puncture hazard should a child step on or fall onto it

NOTE 1 Excluded from this definition are puncture hazards to the eyes and/or mouth, because of the impossibility of eliminating puncture hazards to those areas of the body by product design.

NOTE 2 If the projection is on a small toy which topples over when pressure is applied to the end of the projection, it is unlikely to present a hazard.

3.31**hazardous sharp edge**

accessible edge of a toy which presents an unreasonable risk of injury during normal use and reasonably foreseeable abuse

3.32**hazardous sharp point**

accessible point of a toy which presents an unreasonable risk of injury during normal use or reasonably foreseeable abuse

3.33**hinge-line clearance**

distance between the stationary portion of a toy and the movable portion along or adjacent to a line projected through the axis of rotation

NOTE See Figure 4.

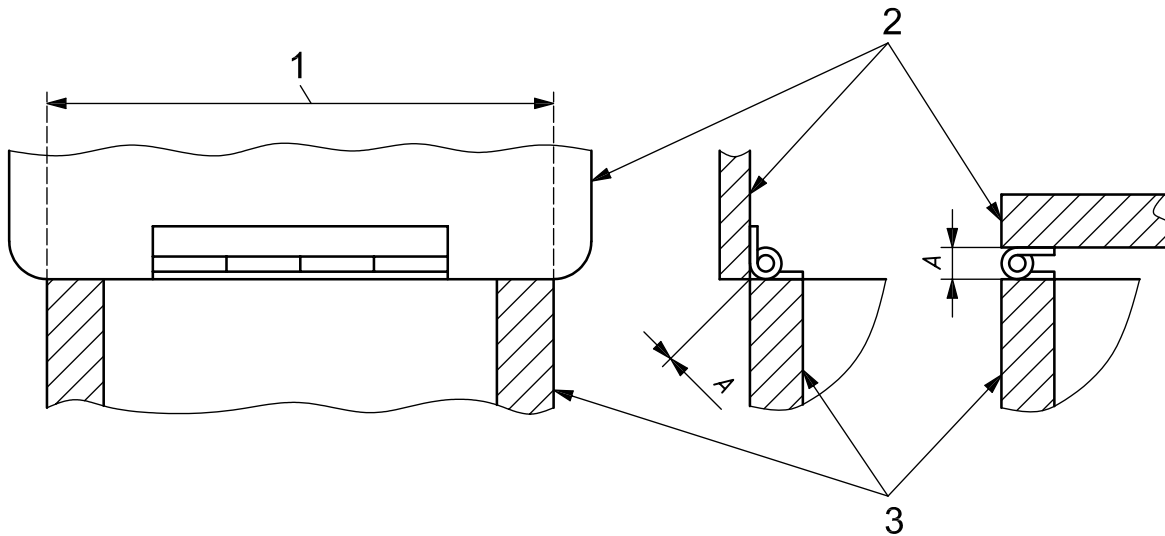

Key

- 1 hinge line
- 2 lid
- 3 box
- A hinge-line clearance between assembled edges

iTeH STANDARD PREVIEW
 (standards.iteh.ai)

3.34 impulsive sound

sound that is characterized by a brief excursion of sound pressure significantly exceeding the ambient noise, typically less than one second in duration

3.35 lap joint

joint in which an edge overlaps a parallel surface but is not necessarily mechanically attached to it at all points along the length

NOTE See Figure 3.

3.36 large and bulky toy

toy that has a projected base area of more than 0,26 m² or a volume of more than 0,08 m³ calculated without regard to minor appendages

NOTE The base area for toys having permanently attached legs is measured by calculating the area enclosed by straight lines connecting the outermost edge of each leg of the perimeter.

3.37 marble

sphere made of hard material, such as glass, agate, marble or plastic, which is used in various children's games, generally as a playing piece or marker

3.38 magnetic component

any part of a toy which contains an attached or fully or partially enclosed magnet

3.39 magnetic/electrical experimental set

toy containing one or more magnets intended for carrying out educational experiments involving both magnetism and electricity

3.40
maximum A-weighted sound pressure level

L_{pAmax}

maximum sound pressure level obtained when using standardized A-weighting

3.41
metal

material comprising elemental metal and/or metal alloys

3.42
normal use

play modes that conform to the instructions which accompany the toy, and which have been established by tradition or custom, or which are evident from an examination of the toy

3.43
packaging

material accompanying the toy when purchased, but having no intended play function

3.44
paper

material, marketed as either paper or paperboard, with a maximum mass per unit area of 400 g/m²

3.45
play furniture

furniture intended for use by a child and intended to, or likely to, support the mass of a child

3.46
pompom

lengths or strands of fibre, yarn or thread clamped or secured and tied in the centre, and brushed up to form a substantially spherical, ovoid or ellipsoidal shape

NOTE 1 This definition includes substantially spherical, ovoid, and ellipsoidal shaped attachments made of stuffed materials (see Figure 5).

NOTE 2 Tassels with long strands are not considered pompoms (see Figure 6).



Figure 5 — Regular and rounded pompoms



Figure 6 — Tassel with long strands

3.47
projectile

object intended to be launched into free flight, or a trajectory, in the air

3.48
projectile toy with stored energy

toy with a projectile propelled by means of a discharge mechanism capable of storing and releasing energy