



Designation: C841 – 03(Reapproved2008)<sup>ε1</sup>

# Standard Specification for Installation of Interior Lathing and Furring<sup>1</sup>

This standard is issued under the fixed designation C841; the number immediately following the designation indicates the year of original adoption or, in the case of revision, the year of last revision. A number in parentheses indicates the year of last reapproval. A superscript epsilon ( $\epsilon$ ) indicates an editorial change since the last revision or reapproval.

*This standard has been approved for use by agencies of the Department of Defense.*

<sup>ε1</sup> NOTE—The units statement in subsection 1.2 was corrected editorially in July 2008.

## 1. Scope

1.1 This specification covers the minimum requirements for, and the methods of application of, interior lathing and furring to receive gypsum plaster applied in accordance with Specification C842. Other materials are not prohibited from being used provided that their physical characteristics and durability under conditions of usage are at least equal in performance to those described.

1.2 The values stated in inch-pound units are to be regarded as standard. The values given in parentheses are mathematical conversions to SI units that are provided for information only and are not considered standard.

1.3 Details of construction for a specific assembly to achieve the required fire resistance shall be obtained from reports of fire-resistance tests, engineering evaluations, or listings from recognized fire testing laboratories.

1.4 Where a specific degree of sound control is required for plastered assemblies and constructions, details of construction shall be obtained from reports of sound tests of assemblies that have met the requirements of Test Method E492.

## 2. Referenced Documents

### 2.1 ASTM Standards:<sup>2</sup>

A641/A641M Specification for Zinc-Coated (Galvanized) Carbon Steel Wire

C11 Terminology Relating to Gypsum and Related Building Materials and Systems

C37/C37M Specification for Gypsum Lath (Withdrawn 2004)<sup>3</sup>

C514 Specification for Nails for the Application of Gypsum Board

C754 Specification for Installation of Steel Framing Members to Receive Screw-Attached Gypsum Panel Products

C842 Specification for Application of Interior Gypsum Plaster

C847 Specification for Metal Lath

C933 Specification for Welded Wire Lath

C954 Specification for Steel Drill Screws for the Application of Gypsum Panel Products or Metal Plaster Bases to Steel Studs from 0.033 in. (0.84 mm) to 0.112 in. (2.84 mm) in Thickness

C1002 Specification for Steel Self-Piercing Tapping Screws for the Application of Gypsum Panel Products or Metal Plaster Bases to Wood Studs or Steel Studs

C1007 Specification for Installation of Load Bearing (Transverse and Axial) Steel Studs and Related Accessories

C1032 Specification for Woven Wire Plaster Base

D1784 Specification for Rigid Poly(Vinyl Chloride) (PVC) Compounds and Chlorinated Poly(Vinyl Chloride) (CPVC) Compounds

D3678 Specification for Rigid Poly(Vinyl Chloride) (PVC) Interior-Profile Extrusions

E492 Test Method for Laboratory Measurement of Impact Sound Transmission Through Floor-Ceiling Assemblies Using the Tapping Machine

2.2 National Association of Architectural Metal Manufacturers Standard

HMMA 840 Installation and Storage of Hollow Metal Doors and Frames<sup>4</sup>

## 3. Terminology

3.1 *Definitions*—For definitions relating to ceilings and walls see Terminology C11.

<sup>1</sup> This specification is under the jurisdiction of ASTM Committee C11 on Gypsum and Related Building Materials and Systems and is the direct responsibility of Subcommittee C11.03 on Specifications for the Application of Gypsum and Other Products in Assemblies.

Current edition approved May 1, 2008. Published July 2008. Originally approved in 1976. Last previous edition approved in 2003 as C841 – 03. DOI: 10.1520/C0841-03R08E01.

<sup>2</sup> For referenced ASTM standards, visit the ASTM website, www.astm.org, or contact ASTM Customer Service at service@astm.org. For *Annual Book of ASTM Standards* volume information, refer to the standard's Document Summary page on the ASTM website.

<sup>3</sup> The last approved version of this historical standard is referenced on www.astm.org.

<sup>4</sup> Available from NAAMM, 8 South Michigan Avenue, Suite 1000, Chicago, IL 60603.

\*A Summary of Changes section appears at the end of this standard

3.2 Definitions of Terms Specific to This Standard:

3.2.1 *base coat, n*—the sum of the scratch and brown coats or the total coats in place prior to application of finish coats.

3.2.2 *contact ceiling, n*—a ceiling in which the lath is attached in direct contact with the construction above, without the use of main runners or cross furring.

3.2.3 *furred ceiling, n*—a ceiling in which the furring used for the support of the lath is attached directly to the structural members of the building.

3.2.4 *suspended ceiling, n*—a ceiling in which the main runners and cross furring are suspended below the structural members of the building.

3.2.5 *main runners, n*—the members that are attached to or suspended from the construction above for the support of cross furring.

3.2.6 *cross furring, n*—furring members that are attached at right angles to the underside of the main runners or construction above for support of the lath.

3.2.7 *furring, n*—spacer strips fastened to a wall, ceiling, or planar element that create an even surface for the application of metal plaster bases or gypsum lath.

3.2.8 *primary members, n*—the members (main runners or structural supports) to which the cross furring is attached.

3.2.9 *metal plaster bases, n*—expanded metal lath, sheet metal lath, welded or woven wire lath.

3.2.10 *face side (gypsum lath), n*—the side opposite the paper cover seam laps.

3.2.11 *surface transition, n*—the change in width of a surface, usually as a result of penetrations (doors, windows) or architectural demands.

4. Delivery of Materials

4.1 All materials shall be delivered in the original packages, containers, or bundles bearing the brand name and manufacturer’s (or supplier’s) identification.

5. Storage of Materials

5.1 All materials shall be kept dry, preferably by being stored inside. Where necessary to be stored outside, materials shall be stacked off the ground, supported on a level platform, and protected from the weather and surface contamination.

5.2 Materials shall be neatly stacked flat with care taken to avoid damage to edges, ends, or surfaces.

6. Materials

6.1 Wire Specification A641/A641M, Class 1 coating (galvanized) soft temper.

6.1.1 *Tie Wire and Hanger Wire*—Zinc-coated (galvanized) soft-annealed steel, or a material having equivalent size, corrosion resistance and strength. Wire diameters (uncoated) specified herein correspond with United States steel wire gage numbers as follows:

Diameter, in. <sup>A</sup>	(mm)	Wire Gage (U.S. Steel Wire Gage)
0.0348	(0.88)	No. 20

Diameter, in. <sup>A</sup>	(mm)	Wire Gage (U.S. Steel Wire Gage)
0.0410	(1.04)	No. 19
0.0475	(1.21)	No. 18
0.0540	(1.37)	No. 17
0.0625	(1.59)	No. 16
0.0800	(2.03)	No. 14
0.0915	(2.32)	No. 13
0.1055	(2.68)	No. 12
0.1205	(3.06)	No. 11
0.1350	(3.43)	No. 10
0.1483	(3.77)	No. 9
0.1620	(4.11)	No. 8

<sup>A</sup>Allowable variations in diameter shall be in accordance with tolerances as established in A641/A641M.

6.2 *Gypsum Lath*—Specification C37/C37M.

6.3 *Expanded Metal Lath*—Specification C847.

6.4 *Wire Lath:*

6.4.1 *Welded Wire Lath*, Specification C933.

6.4.2 *Woven Wire Lath*, Specification C1032.

6.5 *Fasteners:*

6.5.1 *Nails for Attaching Gypsum Lath*—Specification C514. Nail size shall be in accordance with Table 1.

6.5.2 *Nails for Attaching Metal Plaster Base*—Galvanized roofing nails or common nails. length shall be as specified in 7.

6.5.3 *Screws*—Specifications C954 or C1002.

6.5.3.1 Screws for attaching gypsum lath shall be sized in accordance with Table 1.

6.5.3.2 Screws for attaching metal plaster base shall have a 7/16 in. (11.1 mm) diameter pan washer head and a 0.120 in. (3.0 mm) diameter shank. The length shall be sufficient enough to allow for the threaded portion of the screw to project not less than 3/8 in. (9.5 mm) through steel framing when the lath is installed.

6.5.4 *Staples*—Staples for attaching gypsum lath shall conform to the requirements of Table 1.

6.5.4.1 Staples for attaching metal plaster base shall be 0.062 in. (1.6 mm) diameter, round or flattened steel wire with 3/4 in. (19.0 mm) crown. Lengths shall be as specified for individual systems.

6.6 *Paper or Other Backing*—When used on metal plaster bases, over solid backing, backing shall be securely held in place by, or attached to the metal plaster base. Metal plaster base shall allow for 1/4 in. (6.4 mm) self furring. The backing shall permit embedment of plaster.

6.7 *Accessories*—Shall be steel, coated, with a protective rust inhibitive coating after fabrication, or fabricated from zinc-coated (galvanized) steel, aluminum, zinc alloy, or high impact plastic. Plastic accessories shall be nmanufactured in accordance with Specification D1784 or Specification D3678. Aluminum accessories shall be clear plastic coated. All accessories shall have perforated or expanded flanges or clips shaped so as to permit complete imbedment in the plaster, to provide means for secure alignment, and to secure attachment of the accessory to the underlying surface. Accessories shall be designed for the intended use and to receive or to permit application of the specified plaster thickness.

**TABLE 1 Screws, Nails and Staples<sup>A,B</sup> for Attaching Gypsum Lath to Horizontal and Vertical Wood Supports**

Maximum Spacing, in. (mm)					Minimum Gage Requirements, in. (mm)			
Width of Lath	Thickness of Lath	Distance Between Supports	Number of Attachments per Bearing	Approximate Spacing <i>c</i> to <i>c</i> of Attachments	Length of Leg	Depth of Support Penetration	Diameter of Flat Head or Blued Nails or Crown Width of Staples <sup>A</sup>	Gage of Shank of Nails or Staples <sup>A</sup>
16 (406)	3/8 (9.5)	16 (406)	4	5 (127)	1 1/8 (28.6)	3/4 (19)	19/64 (7.5)	13
					1 (25.4) <sup>A</sup>	5/8 (15.9) <sup>A</sup>	7/16 (11) <sup>A</sup>	16 <sup>A</sup>
24 (610)	3/8 (9.5)	16 (406)	6	4 1/2 (114)	1 1/8 (28.6)	3/4 (19)	19/64 (7.5)	13
					1 (25.4) <sup>A</sup>	5/8 (15.9) <sup>A</sup>	7/16 (11) <sup>A</sup>	16 <sup>A</sup>
16 (406)	1/2 (12.7)	24 (610)	4	5 (127)	1 1/4 (32)	3/4 (19)	19/64 (7.5)	13
					1 1/8 (28.6) <sup>A</sup>	5/8 (15.9) <sup>A</sup>	7/16 (11) <sup>A</sup>	16 <sup>A</sup>
24 (610)	1/2 (12.7)	24 (610)	6	4 1/2 (114)	1 1/4 (32)	3/4 (19)	19/64 (7.5)	13 (330)
					1 1/8 (28.6) <sup>A</sup>	5/8 (15.9) <sup>A</sup>	7/16 (11) <sup>A</sup>	16 <sup>A</sup>
48 (1219)	3/8 (9.5)	16 (406)	8	4 1/2 (114)	1 1/8 (28.6)	3/4 (19)		
					1 (25.4) <sup>A</sup>	5/8 (15.9) <sup>A</sup>		
					1 1/4 (32)	3/4 (19)		
	1/2 (12.7)	24 (610)			1 1/8 (28.6) <sup>A</sup>	5/8 (15.9) <sup>A</sup>		

<sup>A</sup> Galvanized staples.

<sup>B</sup> Screws for attaching gypsum lath to wood supports shall be Type W as described in Specification C1002.

6.7.1 Thickness of base material for accessories shall be not less than as shown in the following:

Base Material (mm)	Thickness of Base Material, in.
Uncoated steel/zinc	0.014 (0.36)
PVC	0.030 (0.76)
Aluminum	0.050 (1.27)

6.7.2 *Control Joints*—Shall be formed by using a single prefabricated member or fabricated by installing casing beads back to back with a flexible barrier membrane behind casing beads. The separation spacing shall be not less than 1/8 in. (3.2 mm) or as required by the anticipated thermal exposure range.

6.7.3 *Cornerite*—shall be not less than 1.75 lb/yd<sup>2</sup> (0.85 kg/m<sup>2</sup>) expanded metal lath, galvanized, or given a protective coating of rust inhibitive paint after fabrication, or woven or welded fabric not less than 0.041 in. (1.04 mm) thick an weighing not less than 1.75 lb/yd<sup>2</sup> (0.85 kg/m<sup>2</sup>), fabricated from galvanized wire. When shaped for angle reinforcing, cornerite shall have outstanding legs of not less than 2 in. (50.8 mm).

6.7.4 *Channels*—Shall be cold-rolled steel, free of rust with a coating of rust inhibitive paint or galvanized. Channels used in areas subject to corrosive action of salt air or other corrosive environments, shall be hot-dip galvanized. Weight of the channel shall be not less than as shown in the following:

Size		Weight	
in.	(mm)	lb/1000 lf	(kg/m)
3/4	(19)	277	(0.412)
1 1/2	(38)	414	(0.616)
2	(50)	506	(0.753)
2 1/2	(64)	597	(0.888)

6.7.5 Rod and flat (strap) hangers shall be mild steel, zinc coated or protected with a rust-inhibiting paint.

6.7.6 *Clips*—Devices for attaching framing members to supports or to each other; for attaching lath to framing members; or for securing lath to lath, shall be formed of

zinc-coated (galvanized) steel wire or sheet, and of sufficient size and strength to support the intended load

6.7.7 *Striplath*—Shall be not less than 1.75 lb/yd<sup>2</sup> (0.85 kg/m<sup>2</sup>) expanded metal lath, or woven or welded fabric of not less than 0.041 in. (1.04 mm) thick weighing not less than 1.75 lb/yd<sup>2</sup> (0.85 kg/m<sup>2</sup>) fabricated from galvanized steel.

## 7. Installation

7.1 *General Requirements for Application of Lath and Accessories:*

7.1.1 Lath shall be installed with the long dimension at right angles to supports, unless otherwise specified.

7.1.2 Corner beads shall be installed to protect all external corners and to establish grounds. Corner beads shall be attached to the substrate in such a manner as to ensure proper alignment during application of plaster.

7.1.3 Metal accessories shall be installed so that flanges and clips provided for their attachment are covered by the base coat plaster.

7.1.4 *Control Joints*—Shall be installed in ceilings greater than 2500 ft<sup>2</sup> (232 m<sup>2</sup>) in area and in partition, wall, and wall furring runs greater than 30 ft (9 m) in length. The distance between ceiling control joints shall not be more than 50 ft (15 m) in either direction. A control joint shall be installed where the ceiling framing or furring changes direction. The distance between control joints in walls or wall furring shall be not more than 30 ft (9 m). A control joint shall be installed where an expansion joint occurs in the base exterior wall or ceiling. A ceiling height door frame, installed in accordance with the spacing requirements set forth in this section, is not prohibited from being used as a control joint.

7.1.5 Where partition assemblies require the installation of control joints over the head of door frames to relieve stresses within the assemblies, such control joints shall be installed in the following manner:

7.1.5.1 Where control joints are located at the vertical center of the door opening two metal studs shall be installed not more than ½ in. (12.7 mm) apart over the center of the span at the head of the frame, with the lath installed so that a vertical joint occurs between the studs. A prefabricated control joint or casing beads shall be installed at the joint location.

7.1.5.2 Where control joints are located in line with the door jambs the procedure in 7.1.5.1 shall be followed with the exception that supporting members shall consist of two studs placed side-by-side.

7.1.6 Casing beads or other suitable accessories, shall be used to isolate non-load bearing partitions from load bearing members.

7.1.7 *Workmanship*—Metal construction furring and lathing shall be erected so that finished plaster surfaces will be true to line, level, plumb, square, curved, or as required to receive specified plaster thickness.

7.1.8 Except where frames are required to be fully grouted with plaster, lath shall be inserted into jambs as far as possible and notched to pass anchors.

## 7.2 Application of Gypsum Lath to Supports:

7.2.1 *General*—Gypsum lath shall be installed so that vertical joints occur not less than one full stud space from edges of openings in walls or partitions.

7.2.2 Gypsum lath shall be installed with the face side out and the edges and ends butted together. End joints shall fall on different supports in alternate courses, or the lath shall be installed so that end joints are continuous on one support. In the latter case, the continuous end joints shall be covered with 3-in. (76-mm) wide strips of metal lath or welded or woven wire fabric, and the long edge joints of lath in alternate courses shall be offset or staggered.

7.2.3 Cornerite shall be installed on gypsum lath at all internal angles, and lightly nailed or stapled to the gypsum lath and not to the framing members. Cornerite shall not be used in unrestrained construction, or where other provisions are made for the treatment of internal angles.

7.2.4 Where gypsum lath sheets intersect or where joint surfaces are to be plastered without lathing (such as masonry), a casing bead shall be installed at the intersection or joining.

7.2.5 Gypsum lath shall be reinforced at the corners of doors, windows, or other openings with diagonally installed strips of striplath or wire lath, not less than 6 in. (152 mm) wide by 12 in. (305 mm) long.

7.2.6 Metal lath stripping shall be used to cover chases and similar breaks in continuity or horizontal or vertical surfaces that are to receive plaster. Stripping shall be extended not less than 3 in. (76 mm) on all sides of the openings.

## 7.3 Application of Gypsum Lath to Wood Supports:

7.3.1 Except where required otherwise, for certain fire-resistant construction, gypsum lath shall be securely attached to wood supports using nails, screws, or staples conforming to **Table 1**.

7.3.2 Nails and screws shall be driven so that the face of the head is flush with the face of the gypsum lath, and not less than ⅜ in. (9.5 mm) from the edges of the lath. Staples shall be

driven with the crown parallel to the nailing members. The crown shall bear lightly against, but not cut into, the face of the lath.

## 7.4 Application of Gypsum Lath to Metal Supports:

7.4.1 Gypsum lath shall be attached to horizontal or vertical metal supports with staples, screws, or nails, or a combination thereof.

7.4.2 Screws shall be driven so that the face of the head is flush with the face of the gypsum lath and not less than ⅜ in. (9.5 mm) from the edges of the lath.

## 7.5 Studless Solid Partitions (Gypsum Lath and Plaster):

7.5.1 Gypsum lath shall be plain, ½ in. (12.7 mm) thick, 24 in. (610 mm) wide, and, when applied vertically, shall be not more than 12 ft (3.7 m) in length.

7.5.2 Wood floor runners shall be secured to the floor using anchors spaced not more than 24 in. (610 mm) on center. Anchors shall penetrate floor surface to a depth of not less than ⅝ in. (15.9 mm). The width of such runners shall correspond to the overall partition thickness and their upper surface shall be grooved parallel to the length of the runner in the center to a depth of not less than ½ in. (12.7 mm) and to a width to accommodate snugly the thickness of the lath.

7.5.3 Metal floor runners shall be anchored to bases and clips at not more than 24 in. (610 mm) on center. Runners shall be designed to hold the lower edge of the lath securely in position.

7.5.4 Metal ceiling runners shall be aligned with floor runners to ensure plumb installation of the lath. Metal ceiling runners shall be firmly secured to the ceiling construction.

7.5.5 Gypsum lath shall be of such length as to allow not less than ¼ in. (6.4 mm) nor more than 1-in. (25.4-mm) top clearance in the ceiling runner. Erect gypsum lath vertically so as to engage the ends in or to the floor and ceiling runners.

7.5.6 The vertical edges of the lath shall be aligned with the vertical joints interlocked or mechanically fastened with type G screws spaced not more than 12 in. (305 mm) on centers.

## 7.6 Application of Metal Plaster Bases to Framing Members:

7.6.1 *General*—The spacing of supports for the type and weight of metal lath used shall be in accordance with the requirements of **Table 2**.

### 7.6.2 Attachments for Metal Plaster Bases to Wood Framing Members:

7.6.2.1 Diamond mesh expanded metal lath, flat rib expanded metal lath, and welded wire lath shall be attached to horizontal wood supports with 1½ in. (38 mm), 0.1205 in. (3.06 mm) shank, ⅞ in. (11 mm) diameter head, barbed, galvanized, or blued roofing nails driven flush with the lath. The metal lath shall be attached to vertical wood supports with 6d common nails, or 1-in. (25-mm) long roofing nails driven in accordance with **Table 1** or 1-in. No. 14 gage wire staples driven flush with the lath.

7.6.2.2 ⅜-in. (9.5-mm) rib expanded metal lath shall be attached to horizontal and vertical wood supports with nails or staples not less than ⅜ in. (9.5 mm) longer than required (**7.6.2.1**) to provide not less than ⅜-in. (9.5-mm) longer than required (see **7.6.2.1**) to provide penetration in accordance with **Table 1**.

**TABLE 2 Types and Weights of Expanded Metal Lath, Sheet Lath, or Welded Wire Lath and Corresponding Maximum Permissible Spacing of Supports<sup>A</sup>**

Type of Metal Plastering Base	Minimum Weight of Metal Base, lb/yd <sup>2</sup> (kg/m <sup>2</sup> )	Maximum Permissible Spacing of Supports Center for Center, in. (mm)				
		Walls (Partitions)			Ceilings	
		Wood Studs	Solid Partitions	Steel Studs, Wall Furring, etc.	Wood or Concrete	Metal
Expanded metal lath:						
Diamond mesh	2.5 (0.08)	16 (406)	16 (406)	16 (406)	12 (305)	12 (305)
	3.4 (0.12)	16 (406)	16 (406)	16 (406)	10 (254)	16 (406)
Flat rib	2.5 (0.08)	16 (406)	12 (305)	12 (305)	12 (305)	12 (305)
	2.75 (0.09)	16 (406)	16 (406)	16 (406)	16 (406)	16 (406)
	3.4 (0.12)	19 (483)	24 (610)	19 (483)	19 (483)	19 (483)
Flat rib (large opening)	1.8 (0.06)	24 (610)	24 (610)	24 (610)	16 (406)	16 (406)
<sup>3</sup> / <sub>8</sub> -in. (9.5-mm) rib						
	3.4 (0.12)	24 (610)	N/A	19 (482)	19 (482)	19 (482)
	4.0 (0.14)	24 (610)	N/A	24 (610)	24 (610)	24 (610)
Wire lath welded	1.4 (0.05) <sup>B</sup>	16 (406)	16 (406)	16 (406)	16 (406)	16 (406)
	1.95 (0.07) <sup>C</sup>	24 (610)	24 (610)	24 (610)	24 (610)	24 (610)

<sup>A</sup> Paper-backed lath shall be limited to lath having an absorbent and a perforated slotted paper separator only.

<sup>B</sup> Welded wire paper-backed lath, 16-gage, 0.0598 in., (1.52 mm).

<sup>C</sup> Welded wire, paper-backed lath, 16-gage face wire, 0.0598 in. (1.52 mm) face wire.

7.6.2.3 When used on vertical wood supports, common nails shall be bent over to engage not less than three strands of lath. When used for the application of rib lath, common nails shall be bent over to engage not less than one rib of the lath.

7.6.2.4 Other methods of attachment shall be used when it can be shown they provide a carrying strength not less than that described in 7.6.2.1-7.6.2.3 may be used.

#### 7.6.3 Attachments for Metal Plaster Bases to Metal Framing Members:

7.6.3.1 Metal plaster bases shall be attached to metal framing members with 0.048 in. (1.2 mm) diameter wire ties, clips, or modified truss (wafer-headed) screws installed so that the threaded portion of the screw will penetrate the metal supports not less than <sup>3</sup>/<sub>8</sub> in. (9.5 mm) and the head shall contact not less than three strands of lath.

7.6.3.2 Rib metal lath shall be attached to open web steel joists using single ties of galvanized, annealed steel wire, 0.048 in. (1.2 mm) in diameter, with the ends of each tie wire twisted together 1½ times.

7.6.3.3 Rib metal lath shall be installed to metal framing members with the point of the V rib in contact with the framing and attached to the framing by a screw driven through the rib so that the threaded portion of the screw penetrates the metal support not less than <sup>3</sup>/<sub>8</sub> in. (9.5 mm).

7.6.4 Attachments for Metal Plaster Bases to Concrete Supports—Rib metal lath shall be attached to concrete joists by loops of galvanized, annealed steel wire, not less than 0.076 in. (1.9 mm) in diameter, with the ends of each loop twisted together not less than 1½ times.

7.6.5 Spacing of Attachments for Metal Plaster Bases—Attachments for securing metal plaster bases to supports shall be spaced not more than 7 in. (178 mm) apart for diamond mesh and flat rib laths and at each rib for <sup>3</sup>/<sub>8</sub>-in. (9.5-mm) rib lath.

#### 7.6.6 Lapping of Metal Plaster Bases:

7.6.6.1 Side laps of metal plaster bases shall be secured to supports, and tied between supports at intervals not more than 9 in. (229 mm) on center.

7.6.6.2 Expanded metal lath shall be lapped ½ in. (12.7 mm) at edges, or the edge ribs shall be nested. Welded or woven wire lath shall be lapped one mesh at sides and ends. Expanded metal lath shall be lapped 1 in. (25 mm) at ends or ends shall be nested. When end laps occur between supports, the ends of sheets of all metal plaster bases shall be tied together with 0.048 in. (1.2 mm), galvanized, annealed steel wire. Laps shall be located not more than 3 in. (76.2 mm) from the structural support. Lath shall be lapped not more than 3 in. (76.2 mm) in any direction.

7.6.6.3 Adjacent sheets of metal plaster base shall be installed so that metal laps onto metal and backing laps onto backing.

#### 7.6.7 Procedure for Application of Metal Plaster Bases to Ceiling Framing Members:

7.6.7.1 Metal plaster bases shall be applied to ceilings first.

7.6.7.2 The ends of metal plaster bases shall be staggered.

7.6.7.3 Where furred or suspended ceilings greater than 50 ft (15 m) in either direction or 2500 ft<sup>2</sup> (232 m<sup>2</sup>) in area butt into or are penetrated by columns, walls, beams, or other elements, the following procedure shall be used: The sides and ends of the ceiling lath shall abut at the horizontal internal angles and terminate at a casing bead, control joint, or similar device designed to isolate the plaster membrane from the adjoining vertically oriented elements. Only casing beads shall be used at internal angles between ceilings, walls, or partitions. Lath shall not be continuous through control joints but shall be stopped and tied to the flanges of the control joint at each side.

7.6.8 Ends of sheets of diamond mesh metal lath and welded wire lath on partitions not abutting structural walls, columns, or floor-ceiling slabs shall be bent into or around vertical corners and continued on to not less than one support away from the

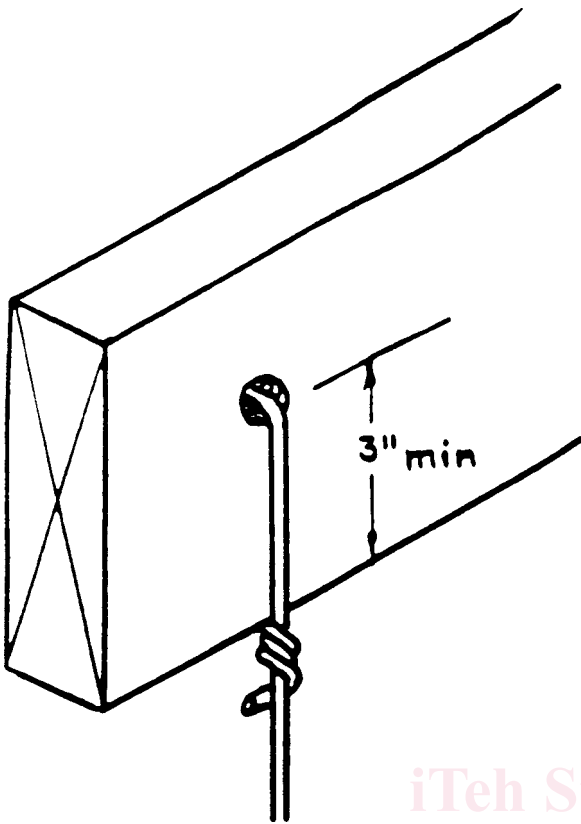

FIG. 1 Hanger Attached to Support Through a Drilled Hole

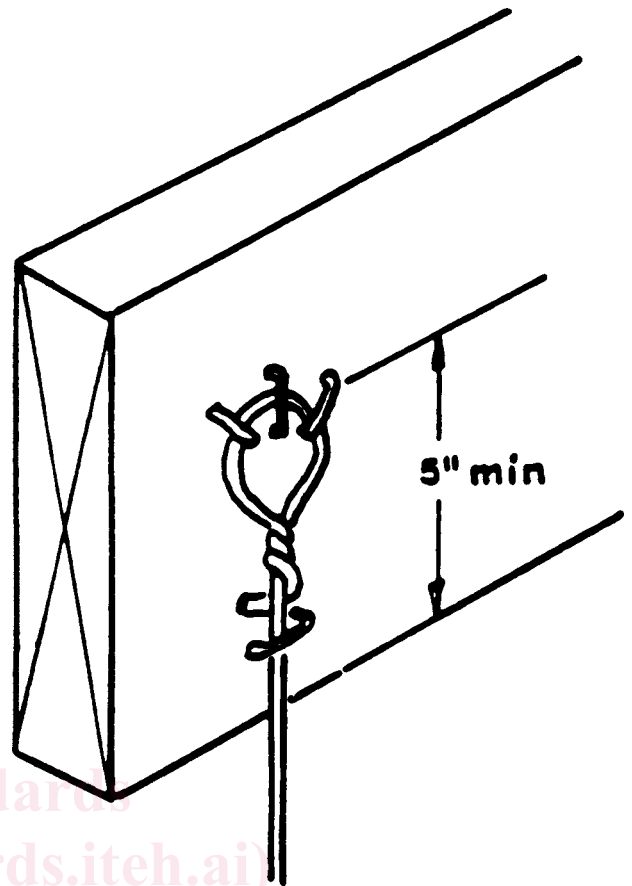

FIG. 3 Hanger Attached to Support Using Staples

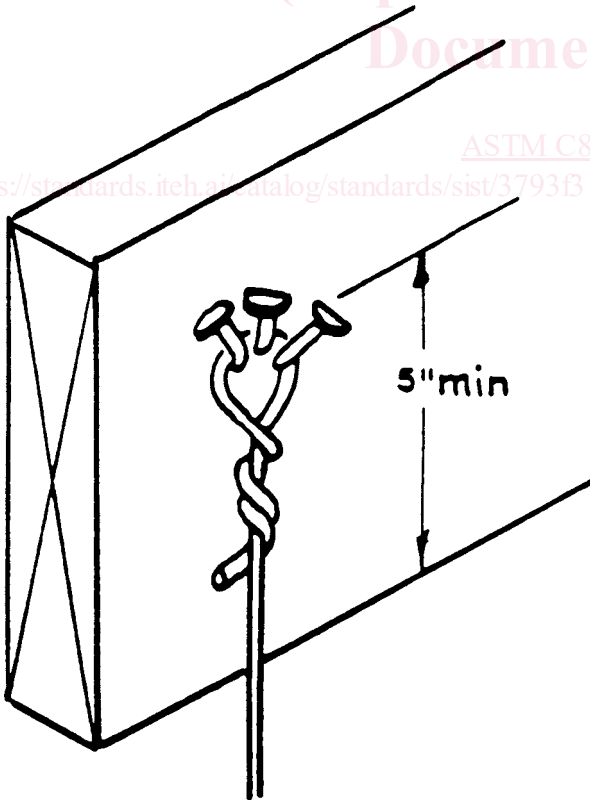

FIG. 2 Hanger Attached to Support Using Nails

corners when cornerite is applied over the abutting laths. Rib metal lath shall be butted into corners and cornerite shall be applied over the abutting laths.

7.6.9 The ends of metal plaster bases applied to load-bearing wall and partitions that abutt structural walls, columns, or floor-ceiling slabs shall be isolated from the adjacent surface at the internal angle. Cornerite shall not be used at internal angles, only casing beads or control joint materials shall be used to isolate the lath and plaster from the abutting surface.

7.7 *Studless Solid Partitions (Metal Lath and Plaster):*

7.7.1 Metal plaster bases used for studless solid partitions shall have the sides (long dimensions) of the sheet installed vertically. The plaster bases shall be wired to the ceiling runners using ties spaced not more than 8 in. (203 mm) on center and mechanically anchored to the floor runners or base.

7.7.1.1 At vertical internal and external corners, metal plaster bases shall be bent and returned 6 in. (152 mm) on abutting surfaces. Rib metal lath shall be lapped 1/2 in. (12.7 mm) at sides, or the outside ribs shall be nested. Side laps shall be wire tied between supports at intervals not more than 9 in. (229 mm) on center.

7.8 *Suspended and Furred Ceilings (Metal Lath and Gypsum Lath Construction):*

7.8.1 Hangers shall be of sufficient length to accommodate the ceiling construction.

7.8.1.1 Hangers (without inserts) shall be secured or otherwise embedded so as to develop full strength.

corner. The ends of the sheets of lath shall be butted into