**Gasoline engines — Medium pressure
liquid fuel supply connections —**

**Part 2:
Pipe assemblies**

*Moteurs à essence — Connections pour des lignes de combustible
liquide à moyenne pression —*

Partie 2: Lignes assemblées

iTeh STANDARD PREVIEW
(standards.iteh.ai)

ISO 18418-2:2014

<https://standards.iteh.ai/catalog/standards/sist/f545a7dd-80c5-4e7a-944f-82614a0b29d8/iso-18418-2-2014>



iTeh STANDARD PREVIEW
(standards.iteh.ai)

ISO 18418-2:2014

<https://standards.iteh.ai/catalog/standards/sist/f545a7dd-80c5-4e7a-944f-82614a0b29d8/iso-18418-2-2014>



COPYRIGHT PROTECTED DOCUMENT

© ISO 2014

All rights reserved. Unless otherwise specified, no part of this publication may be reproduced or utilized otherwise in any form or by any means, electronic or mechanical, including photocopying, or posting on the internet or an intranet, without prior written permission. Permission can be requested from either ISO at the address below or ISO's member body in the country of the requester.

ISO copyright office
Case postale 56 • CH-1211 Geneva 20
Tel. + 41 22 749 01 11
Fax + 41 22 749 09 47
E-mail copyright@iso.org
Web www.iso.org

Published in Switzerland

Contents

	Page
Foreword.....	iv
Introduction.....	v
1 Scope.....	1
2 Normative references.....	1
3 Dimensions and tolerances.....	1
4 Cleanliness.....	3
5 Minimum bend radii.....	3
6 Pipe end connections.....	3
6.1 General.....	3
6.2 Type of connection ends.....	3
6.3 Pipe end assembly for 60° female cones.....	4
7 Operating pressure.....	5
8 Ovality of bending portion.....	5
9 Tightening torque and sealing performance.....	5
10 Designation.....	6
11 Packaging and identification.....	6
Bibliography.....	7

iTech STANDARD PREVIEW
(standards.iteh.ai)

[ISO 18418-2:2014](https://standards.iteh.ai/catalog/standards/sist/f545a7dd-80c5-4e7a-944f-82614a0b29d8/iso-18418-2-2014)

<https://standards.iteh.ai/catalog/standards/sist/f545a7dd-80c5-4e7a-944f-82614a0b29d8/iso-18418-2-2014>

Foreword

ISO (the International Organization for Standardization) is a worldwide federation of national standards bodies (ISO member bodies). The work of preparing International Standards is normally carried out through ISO technical committees. Each member body interested in a subject for which a technical committee has been established has the right to be represented on that committee. International organizations, governmental and non-governmental, in liaison with ISO, also take part in the work. ISO collaborates closely with the International Electrotechnical Commission (IEC) on all matters of electrotechnical standardization.

The procedures used to develop this document and those intended for its further maintenance are described in the ISO/IEC Directives, Part 1. In particular the different approval criteria needed for the different types of ISO documents should be noted. This document was drafted in accordance with the editorial rules of the ISO/IEC Directives, Part 2 (see www.iso.org/directives).

Attention is drawn to the possibility that some of the elements of this document may be the subject of patent rights. ISO shall not be held responsible for identifying any or all such patent rights. Details of any patent rights identified during the development of the document will be in the Introduction and/or on the ISO list of patent declarations received (see www.iso.org/patents).

Any trade name used in this document is information given for the convenience of users and does not constitute an endorsement.

For an explanation on the meaning of ISO specific terms and expressions related to conformity assessment, as well as information about ISO's adherence to the WTO principles in the Technical Barriers to Trade (TBT) see the following URL: [Foreword - Supplementary information](#)

The committee responsible for this document is ISO/TC 22, *Road vehicles*, Subcommittee SC 7, *Injection equipment and filters for use on road vehicles*.

ISO 18418 consists of the following parts, under the general title *Gasoline engines — Medium pressure liquid fuel supply connections*:

- Part 1: *60° female cone connectors*
- Part 2: *Pipe assemblies*

Introduction

Some spark ignition (SI) engines use direct injection (DI) fuel systems which supply gasoline under pressure to a rail and to the injectors via pipe assemblies with a 60° female cone connector. Such components are similar to ISO 2974 and ISO 13296 for the diesel injection systems except for the relationship between the outside and inside diameters of the pipes due to the lower pressure range.

iTeh STANDARD PREVIEW
(standards.iteh.ai)

[ISO 18418-2:2014](https://standards.iteh.ai/catalog/standards/sist/f545a7dd-80c5-4e7a-944f-82614a0b29d8/iso-18418-2-2014)

<https://standards.iteh.ai/catalog/standards/sist/f545a7dd-80c5-4e7a-944f-82614a0b29d8/iso-18418-2-2014>

iTeh STANDARD PREVIEW
(standards.iteh.ai)

[ISO 18418-2:2014](#)

<https://standards.iteh.ai/catalog/standards/sist/f545a7dd-80c5-4e7a-944f-82614a0b29d8/iso-18418-2-2014>

Gasoline engines — Medium pressure liquid fuel supply connections —

Part 2: Pipe assemblies

1 Scope

This part of ISO 18418 specifies dimensions and requirements for medium-pressure fuel pipe assemblies and assembled pipe sets made of seamless stainless steel tubing to be used with 60° female cone connectors on gasoline (spark-ignition) engines.

NOTE 1 Dimensions of 60° female cone connectors are specified in ISO 18418-1.

NOTE 2 Material properties of stainless steel tubing are specified in ISO 9329-4. The chemical composition of stainless steels can be found in ISO 15510.

2 Normative references

The following documents, in whole or in part, are normatively referenced in this document and are indispensable for its application. For dated references, only the edition cited applies. For undated references, the latest edition of the referenced document (including any amendments) applies.

ISO 9329-4:1997, *Seamless steel tubes for pressure purposes — Technical delivery conditions — Part 4: Austenitic stainless steels*

ISO 12345, *Diesel engines — Cleanliness assessment of fuel injection equipment*

ISO 15510:2014, *Stainless steels — Chemical composition*

ISO 18418-1:2014, *Gasoline engines — Medium pressure liquid fuel supply connections — Part 1: 60° female cone connectors*

3 Dimensions and tolerances

The requirement and configuration drawing for a pipe assembly shall include at least the following:

- indication of compliance with this part of ISO 18418;
- the thread and the hexagon size of the connector nuts according to [Tables 1](#) and [2](#);
- the type of the connection ends as specified in [6.2](#);
- a graphic representation of the centreline of the pipe with the connection ends and each bend intersection labelled as a point, with each point listed in a table with Cartesian coordinates x, y , and z with the orthogonal distance from the axis and the bend radius (the beginning and end points are given as the “ S ” dimension for the defined configuration);

NOTE The coordinates are used to specify the theoretical exact centreline of the pipe. See the example given in [Figure 1](#).

- the developed length of the pipe as an approximated value;
- the material and surface finish requirements of the pipe and connector nuts.

The dimensional tolerance of a pipe assembly shall be stated in terms of the actual outside contour of the tube in relation to the specified maximum outside contour and the variance of the actual pipe connection end from specified position, as agreed between supplier and customer.

Dimensions in millimetres

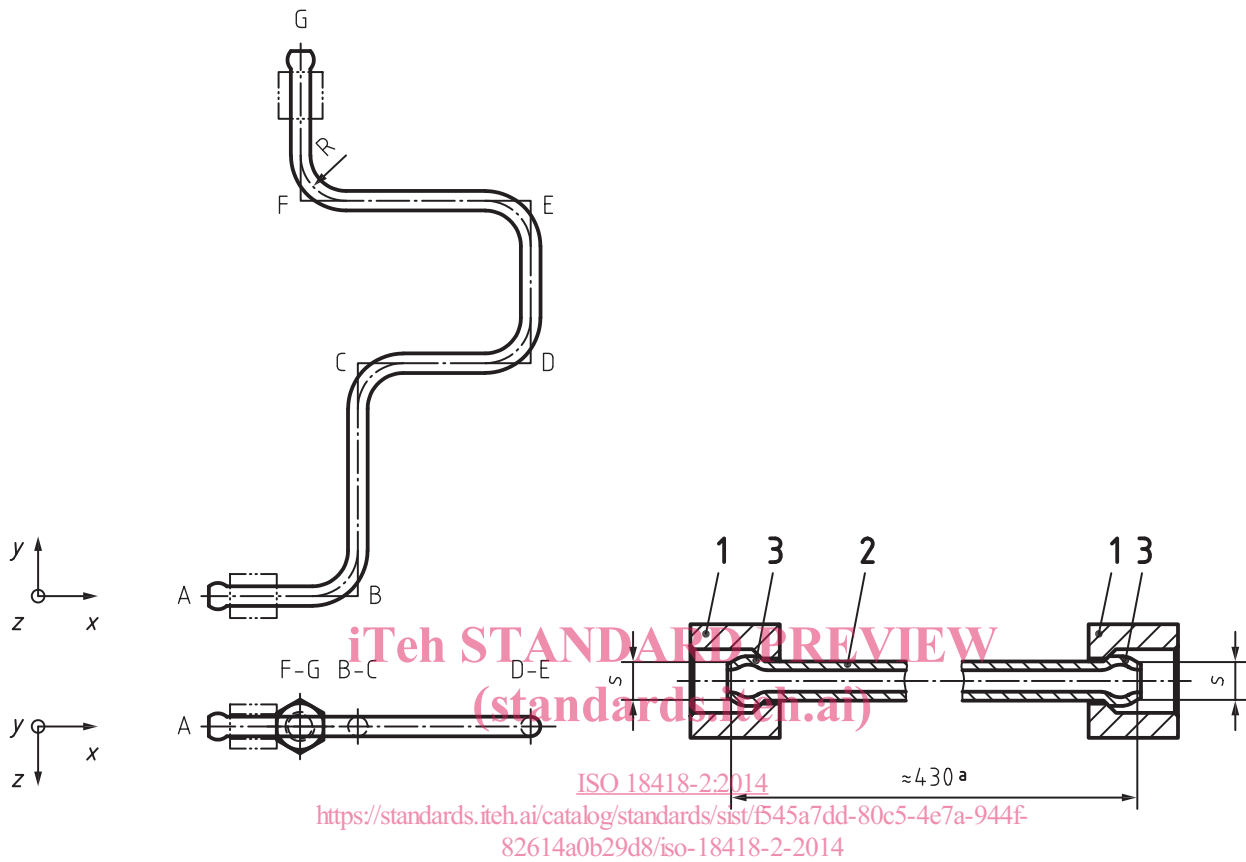

Point	x	y	z	Radius
A	0	0	0	0
B	65	0	0	20
C	65	100	0	20
D	140	100	0	20
E	140	170	0	20
F	40	170	0	20
G	40	235	0	0

Key

- 1 connector nut: thread M14; hexagon across flats 17
- 2 pipe: tube outside diameter 8 mm
- 3 pipe connection ends
- ^a Developed length.

NOTE For dimension S see, [Table 1](#).

Figure 1 — Example of a requirement and configuration drawing

4 Cleanliness

The bore of a pipe assembly shall be clean, and this shall be assessed in accordance with ISO 12345. Unless otherwise agreed between supplier and customer, cleanliness of pipe assemblies shall be designated using the Fuel Injection Equipment Cleanliness Code (FIECC), as defined in ISO 12345.

5 Minimum bend radii

The radius of any bend made in fabricating pipe assemblies shall be not less than two and one-eighth times ($2,125\times$) the outside diameter of the pipe as measured from the pipe centreline. Bends shall be a sufficient distance from the end-connections so as to allow easy fitting of the pipe assembly for its intended use. Bends shall be a sufficient distance from one another so as not to impair fabrication. Bend radii shall be of uniform size in each pipe assembly whenever possible.

6 Pipe end connections

6.1 General

The relationships of connection ends to the connector nut and with the dimensions G and S are shown in [Table 1](#) for the 60° female cone.

The design of the shoulders of the connection end and of the related connector nut shall be agreed between supplier and customer.

NOTE The dimensional characteristics of 60° female cones are described in ISO 18418-1.

6.2 Type of connection ends

In [Figure 2](#), the design of connection ends with a spherical sealing face for pipe assemblies is shown.

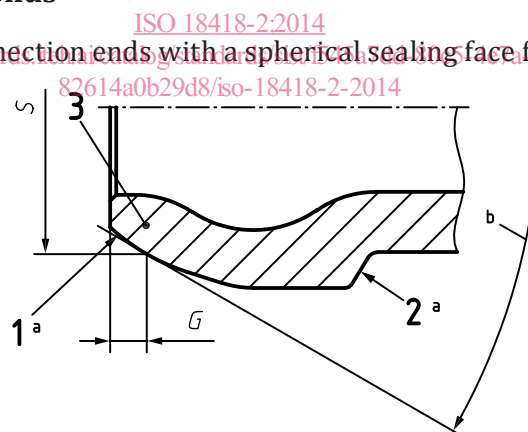

Key

- 1 connection end sealing face (spherical)
- 2 shoulder of connection end
- 3 connection end of pipe
- a Spherical shape of the connection end sealing face and of the shoulder in order to allow an inclined position of the pipe connection end to the matching female cone.
- b Spherical connection end to fit into the 60° female cone specified in ISO 18418-1.

NOTE For dimensions G and S , see [Table 1](#).

Figure 2 — Connection end