



SLOVENSKI STANDARD
kSIST FprEN ISO 9934-1:2016
01-september-2016

Neporušitveno preskušanje - Preskušanje z magnetnimi delci - 1. del: Splošna načela (ISO/FDIS 9934-1:2016)

Non-destructive testing - Magnetic particle testing - Part 1: General principles (ISO/FDIS 9934-1:2016)

Zerstörungsfreie Prüfung - Magnetpulverprüfung - Teil 1: Allgemeine Grundlagen (ISO/FDIS 9934-1:2016)

Essais non destructifs - Magnétoscopie - Partie 1: Principes généraux du contrôle (ISO/FDIS 9934-1:2016)

Ta slovenski standard je istoveten z: FprEN ISO 9934-1

ICS:

19.100 Neporušitveno preskušanje Non-destructive testing

kSIST FprEN ISO 9934-1:2016

en,fr,de

FINAL
DRAFTINTERNATIONAL
STANDARDISO/FDIS
9934-1

ISO/TC 135/SC 2

Secretariat: SABS

Voting begins on:
2016-06-27Voting terminates on:
2016-09-19**Non-destructive testing — Magnetic
particle testing —****Part 1:
General principles***Essais non destructifs — Magnétoscopie —**Partie 1: Principes généraux du contrôle*iTeh STANDARD PREVIEW
(standards.iteh.ai)SIST EN ISO 9934-1:2017<https://standards.iteh.ai/catalog/standards/sist/c98d29e3-66ac-4bc2-9029-ac6ed438fe98/sist-en-iso-9934-1-2017>**Please see the administrative notes on page ii**

RECIPIENTS OF THIS DRAFT ARE INVITED TO SUBMIT, WITH THEIR COMMENTS, NOTIFICATION OF ANY RELEVANT PATENT RIGHTS OF WHICH THEY ARE AWARE AND TO PROVIDE SUPPORTING DOCUMENTATION.

IN ADDITION TO THEIR EVALUATION AS BEING ACCEPTABLE FOR INDUSTRIAL, TECHNOLOGICAL, COMMERCIAL AND USER PURPOSES, DRAFT INTERNATIONAL STANDARDS MAY ON OCCASION HAVE TO BE CONSIDERED IN THE LIGHT OF THEIR POTENTIAL TO BECOME STANDARDS TO WHICH REFERENCE MAY BE MADE IN NATIONAL REGULATIONS.

Reference number
ISO/FDIS 9934-1:2016(E)

© ISO 2016

ISO/CEN PARALLEL PROCESSING

This final draft has been developed within the International Organization for Standardization (ISO), and processed under the **ISO-lead** mode of collaboration as defined in the Vienna Agreement. The final draft was established on the basis of comments received during a parallel enquiry on the draft.

This final draft is hereby submitted to the ISO member bodies and to the CEN member bodies for a parallel two-month approval vote in ISO and formal vote in CEN.

Positive votes shall not be accompanied by comments.

Negative votes shall be accompanied by the relevant technical reasons.

iTeh STANDARD PREVIEW (standards.iteh.ai)

[SIST EN ISO 9934-1:2017](https://standards.iteh.ai/catalog/standards/sist/c98d29e3-66ac-4bc2-9029-ac6ed438fe98/sist-en-iso-9934-1-2017)

<https://standards.iteh.ai/catalog/standards/sist/c98d29e3-66ac-4bc2-9029-ac6ed438fe98/sist-en-iso-9934-1-2017>



COPYRIGHT PROTECTED DOCUMENT

© ISO 2016, Published in Switzerland

All rights reserved. Unless otherwise specified, no part of this publication may be reproduced or utilized otherwise in any form or by any means, electronic or mechanical, including photocopying, or posting on the internet or an intranet, without prior written permission. Permission can be requested from either ISO at the address below or ISO's member body in the country of the requester.

ISO copyright office
Ch. de Blandonnet 8 • CP 401
CH-1214 Vernier, Geneva, Switzerland
Tel. +41 22 749 01 11
Fax +41 22 749 09 47
copyright@iso.org
www.iso.org

Contents

	Page
Foreword	iv
1 Scope	1
2 Normative references	1
3 Terms and definitions	1
4 Qualification and certification of personnel	1
5 Safety and environmental requirements	2
6 Testing procedure	2
7 Surface preparation	2
8 Magnetization	2
8.1 General requirements	2
8.2 Verification of magnetization	3
8.3 Magnetizing techniques	3
8.3.1 General	3
8.3.2 Current flow techniques	4
8.3.3 Magnetic flow techniques	6
9 Detection media	10
9.1 Properties and selection of media	10
9.2 Testing of detection media	10
9.3 Application of detection media	10
10 Viewing conditions	10
11 Overall performance test	11
12 Interpretation and recording of indications	11
13 Demagnetization	11
14 Cleaning	11
15 Test report	12
Annex A (informative) Example for determination of currents required to achieve specified tangential field strengths for various magnetization techniques	13

ISO/FDIS 9934-1:2016(E)

Foreword

ISO (the International Organization for Standardization) is a worldwide federation of national standards bodies (ISO member bodies). The work of preparing International Standards is normally carried out through ISO technical committees. Each member body interested in a subject for which a technical committee has been established has the right to be represented on that committee. International organizations, governmental and non-governmental, in liaison with ISO, also take part in the work. ISO collaborates closely with the International Electrotechnical Commission (IEC) on all matters of electrotechnical standardization.

The procedures used to develop this document and those intended for its further maintenance are described in the ISO/IEC Directives, Part 1. In particular the different approval criteria needed for the different types of ISO documents should be noted. This document was drafted in accordance with the editorial rules of the ISO/IEC Directives, Part 2 (see www.iso.org/directives).

Attention is drawn to the possibility that some of the elements of this document may be the subject of patent rights. ISO shall not be held responsible for identifying any or all such patent rights. Details of any patent rights identified during the development of the document will be in the Introduction and/or on the ISO list of patent declarations received (see www.iso.org/patents).

Any trade name used in this document is information given for the convenience of users and does not constitute an endorsement.

For an explanation on the meaning of ISO specific terms and expressions related to conformity assessment, as well as information about ISO's adherence to the World Trade Organization (WTO) principles in the Technical Barriers to Trade (TBT) see the following URL: www.iso.org/iso/foreword.html.

The committee responsible for this document is ISO/TC 135, *Non-destructive testing*, Subcommittee SC 2, *Surface methods*.

This third edition cancels and replaces the second edition (ISO 9934-1:2015), of which it constitutes a minor revision.

ISO 9934 consists of the following parts under the general title *Non-destructive testing — Magnetic particle testing*:

- *Part 1: General principles*
- *Part 2: Detection media*
- *Part 3: Equipment*

Non-destructive testing — Magnetic particle testing —

Part 1: General principles

1 Scope

This part of ISO 9934 specifies general principles for the magnetic particle testing of ferromagnetic materials. Magnetic particle testing is primarily applicable to the detection of surface-breaking discontinuities, particularly cracks. It can also detect discontinuities just below the surface but its sensitivity diminishes rapidly with depth.

This part of ISO 9934 specifies the surface preparation of the part to be tested, magnetization techniques, requirements and application of the detection media, and the recording and interpretation of results. Acceptance criteria are not defined. Additional requirements for the magnetic particle testing of particular items are defined in product standards (see the relevant ISO or EN standards).

This part of ISO 9934 does not apply to the residual magnetization method.

2 Normative references

The following documents, in whole or in part, are normatively referenced in this document and are indispensable for its application. For dated references, only the edition cited applies. For undated references, the latest edition of the referenced document (including any amendments) applies.

ISO 3059, *Non-destructive testing — Penetrant testing and magnetic particle testing - Viewing conditions*

ISO 9712, *Non-destructive testing — Qualification and certification of NDT personnel*

ISO 9934-2, *Non-destructive testing — Magnetic particle testing — Part 2: Detection media*

ISO 9934-3, *Non-destructive testing — Magnetic particle testing — Part 3: Equipment*

ISO 12707, *Non-destructive testing — Magnetic particle testing — Vocabulary*

EN 1330-1, *Non-destructive testing — Terminology — Part 1: General terms.*

EN 1330-2, *Non-destructive testing — Terminology — Part 2: Terms common to non-destructive testing methods*

EN 1330-7, *Non-destructive testing — Terminology — Terms used in magnetic particle testing*

3 Terms and definitions

For the purposes of this document, the terms and definitions given in ISO 12707, EN 1330-1, EN 1330-2, and EN 1330-7 apply.

4 Qualification and certification of personnel

It is assumed that magnetic particle testing is performed by qualified and capable personnel. In order to provide this qualification, it is recommended to certify the personnel in accordance with ISO 9712 or equivalent.

ISO/FDIS 9934-1:2016(E)

5 Safety and environmental requirements

All international, European, national, and local regulations which include health, safety and environment shall be taken into account.

Magnetic particle testing often creates high magnetic fields close to the object under test and the magnetizing equipment. Items sensitive to these fields should be excluded from such areas.

6 Testing procedure

When required at the time of enquiry and order, magnetic particle testing shall be performed in accordance with a written procedure.

The procedure can take the form of a brief technique sheet, containing a reference to this and other appropriate standards. The procedure should specify testing parameters in sufficient detail for the test to be repeatable.

All testing shall be performed in accordance with an approved written procedure or the relevant product standard shall be referenced

7 Surface preparation

Areas to be tested shall be free from dirt, scale, loose rust, weld spatter, grease, oil, and any other foreign materials that can affect the test sensitivity.

The surface quality requirements are dependent upon the size and orientation of the discontinuity to be detected. The surface shall be prepared so that relevant indications can be clearly distinguished from false indications.

Non-ferromagnetic coatings up to approximately 50 μm thickness, such as unbroken adherent paint layers, do not normally impair detection sensitivity. Thicker coatings reduce sensitivity. Under these conditions, the sensitivity shall be verified.

There shall be a sufficient visual contrast between the indications and the test surface. For the non-fluorescent technique, it might be necessary to apply a uniform, thin, temporarily adherent layer of approved contrast aid paint.

8 Magnetization

8.1 General requirements

The minimum magnetic flux density (B) regarded as adequate for testing is 1 T. The applied magnetic field (H) required to achieve this in low-alloy and low-carbon steels is determined by the relative permeability of the material. This varies according to the material, the temperatures, and also with the applied magnetic field and for these reasons, it is not possible to provide a definitive requirement for the applied magnetic field. However, typically a tangential field of approximately 2 kA/m will be required.

Where time varying currents (I) are used to produce a magnetic field (which will also be time varying), it is important to control the crest factor (shape) of the waveform and the method of measurement of the current in order to establish a repeatable technique. Both peak and RMS measurements are typically used and measurement of the values can be affected by the response of the instrument. For this reason, only instruments that respond directly to the waveform shall be used (e.g. true RMS meters with appropriate crest factor capability for accurate RMS measurements). Instruments that calculate peak or RMS values based on theoretical calculation derived from other values shall not be used. This shall also apply to instruments used to measure magnetic fields

Smooth shaped waveforms provide low crest factors and least variation between peak and true RMS values and are regarded as preferable for magnetic particle testing. Waveforms with a crest factor (i.e. I_{pk}/I_{RMS}) greater than 3 shall not be used without documented evidence of the effectiveness of the technique.

When using multidirectional techniques, the current used shall be purely sinusoidal or phase controlled but the phase cutting shall not be more than 90°. Practical demonstration that the technique is effective in all directions shall be carried out (e.g. using sample parts with known defects or shim type indicators).

Provided the permeability is in the normal range and the current measurement methods are controlled as described, calculations based on the use of 2 kA/m can provide a valuable method of technique preparation. The use of either peak current or true RMS current is acceptable if the crest factor is known. Knowing the entire waveform of the magnetizing curve would be optimal, but knowing the crest factor is a good practical approximation. For pure sinusoidal waveforms, the relationship between peak, mean, and RMS is shown in [Annex A](#). Techniques based on calculation shall be verified before implementation.

NOTE 1 For steels, with low relative permeability, a higher tangential field strength might be necessary. If magnetization is too high, spurious background indications can appear, which could mask relevant indications.

If cracks or other linear discontinuities are likely to be aligned in a particular direction, the magnetic flux shall be aligned perpendicular to this direction where possible.

NOTE 2 The flux can be regarded as effective in detecting discontinuities aligned up to 60° from the optimum direction. Full coverage can then be achieved by magnetizing the surface in two perpendicular directions.

Magnetic particle testing should be regarded as a surface NDT method; however, discontinuities close to the surface can also be detected. For time varying waveforms, the depth of magnetization (skin depth) will depend on the frequency of the current waveform. Magnetic leakage fields produced by imperfections below the surface will fall rapidly with distance. Therefore, although magnetic particle testing is not recommended for the detection of imperfections other than on the surface, it can be noted that the use of smooth DC or rectified waveforms can improve detection of imperfections just below the surface.

8.2 Verification of magnetization

The adequacy of the surface flux density shall be established by one or more of the following methods:

- a) by testing a representative component containing fine natural or artificial discontinuities in the least favourable locations;
- b) by measuring the tangential field strength as close as possible to the surface. Information on this is given in ISO 9934-3;
- c) by calculating the tangential field strength for current flow methods, simple calculations are possible in many cases, and they form the basis for current values specified in [Annex A](#);
- d) by the use of other methods based on established principles.

Flux indicators (e.g. shim-type), placed in contact with the surface under test, provide a guide to the magnitude and direction of the tangential field strength, but should not be used to verify that the tangential field strength is acceptable.

8.3 Magnetizing techniques

8.3.1 General

This subclause describes a range of magnetization techniques. Multi-directional magnetization can be used to find discontinuities in any direction. In the case of simple-shaped objects, formulae are given

ISO/FDIS 9934-1:2016(E)

in [Annex A](#) for achieving approximate tangential field strengths. Magnetizing equipment shall meet the requirements of and be used in accordance with ISO 9934-3.

Magnetizing techniques are described in the following subclauses.

More than one technique might be necessary to find discontinuities on all test surfaces and in all orientations. Demagnetization might be required where the residual field from the first magnetization cannot be overcome. Techniques other than those listed can be used provided they give adequate magnetization, in accordance with [8.1](#).

8.3.2 Current flow techniques

8.3.2.1 Axial current flow

Current flow offers high sensitivity for detection of discontinuities parallel to the direction of the current.

Current passes through the component, which shall be in good electrical contact with the pads. A typical arrangement is shown in [Figure 1](#). The current is assumed to be distributed evenly over the surface and shall be derived from the peripheral dimensions. An example of approximate formula for the current required to achieve a specified tangential field strength is given in [Annex A](#).

Care shall be taken to avoid damage to the component at the point of electrical contacts. Possible hazards include excessive heat, burning, and arcing.

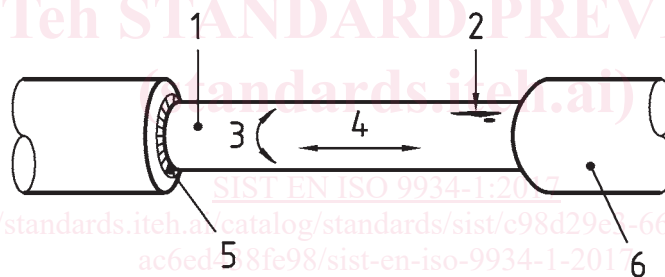

Key

1	specimen	4	current
2	flaw	5	contact pad
3	flux	6	contact head

Figure 1 — Axial current flow

8.3.2.2 Prods; Current flow

Current is passed between hand-held or clamped contact prods as shown in [Figure 2](#), providing an inspection of a small area of a larger surface. The prods are then moved in a prescribed pattern to cover the required total area. Examples of testing patterns are shown in [Figures 2](#) and [3](#). Approximate formulae for the current required to achieve a specified tangential field strength are given in [Annex A](#).

This technique offers the highest sensitivity for discontinuities elongated parallel to the direction of the current. Particular care shall be taken to avoid surface damage due to burning or contamination of the component by the prods. Arcing or excessive heating shall be regarded as a defect requiring a verdict on acceptability. If further testing is required on such affected areas, it shall be carried out using a different technique.

Dimensions in millimetres

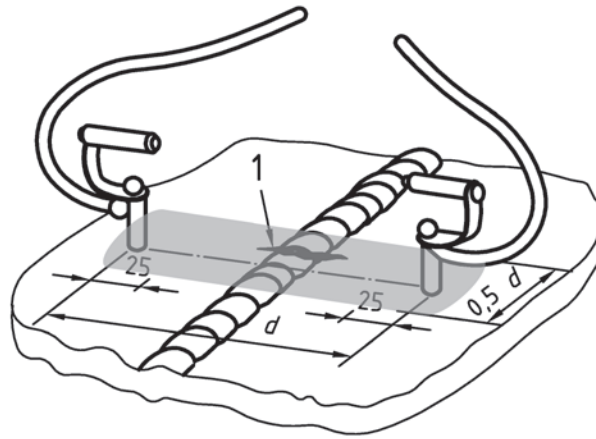
**Key**

1 flaw

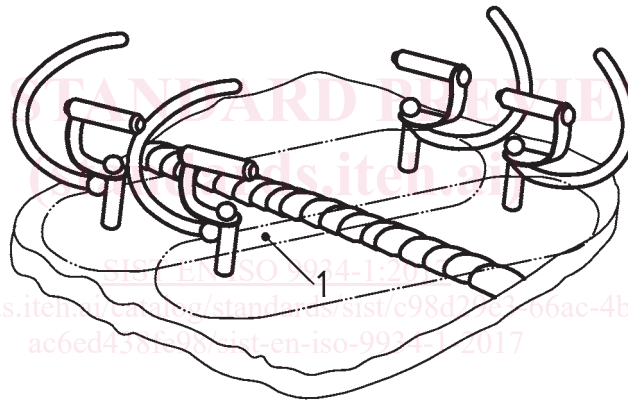
Figure 2 — Prods; Current flow**Key**

1 overlap

Figure 3 — Prods; Current flow**8.3.2.3 Induced current flow**

Current is induced in a ring shaped component by making it, in effect, the secondary of a transformer, as shown in [Figure 4](#). An example of an approximate formula for the induced current required to achieve a specified tangential field strength is given in [Annex A](#).