



Designation: ~~D6478-02 (Reapproved 2007)~~ Designation: D 6478 – 08

Standard Test Method for Determining Specific Packability of Fabrics Used in Inflatable Restraints¹

This standard is issued under the fixed designation D 6478; the number immediately following the designation indicates the year of original adoption or, in the case of revision, the year of last revision. A number in parentheses indicates the year of last reapproval. A superscript epsilon (ϵ) indicates an editorial change since the last revision or reapproval.

1. Scope

1.1 This test method covers procedures for determining the ability to fold and pack fabrics used for inflatable restraints using an index of specific packability.

1.2 Procedures in this test method describe operator techniques that must be followed closely to obtain repeatable and accurate results. Since these techniques are difficult to convey in writing, supplemental training for operators is required. A training video is available from ASTM (see Adjuncts ADJD6478 and ADJD6478A and).

1.3 The values stated in either SI units or inch-pound units are to be regarded separately as standard. The values stated in each system are not exact equivalents; therefore, each system must be used independent of the other.

1.4 Procedures and apparatus other than those stated in this practice may be used as agreed upon between the purchaser and the supplier with specific deviations from this practice acknowledged in the report.

1.5 *This standard does not purport to address all of the safety concerns, if any, associated with its use. It is the responsibility of the user of this standard to establish appropriate safety and health practices, and determine the applicability of regulatory limitations prior to use.*

2. Referenced Documents

2.1 ASTM Standards:²

D 123 Terminology Relating to Textiles

D 1776 Practice for Conditioning and Testing Textiles

D 2904 Practice for Interlaboratory Testing of a Textile Test Method that Produces Normally Distributed Data

D 2906 Practice for Statements on Precision and Bias for Textiles

D 6799 Terminology Relating to Inflatable Restraints

E 691 Practice for Conducting an Interlaboratory Study to Determine the Precision of a Test Method

2.2 ASTM Adjuncts:

ADJD6478 — 17 Detailed Drawings³

ADJD6478A- Videotape-Supplemental Training³

3. Terminology

3.1 Definitions:

3.1.1 For definitions of other textile and statistical terms used in this standard, refer to Terminology D123, Practice D2906 and Terminology D6799.

3.1 For all terminology relating to D13.20, Inflatable restraints, refer to Terminology D 6799.

3.1.1 The following terms are relevant to this standard: inflatable restraint, packability, specific packability.

3.2 For all other terms related to textiles, see Terminology D 123.

4. Summary of Practice

4.1 A fabric specimen is folded uniformly in a “Z” pattern in the warp and fill directions.

4.2 The folded specimen is placed into a transparent box that confines the specimen securely during compression.

4.3 The folded specimen is compressed using a tensile tester outfitted with special hardware, and the resulting volume is

¹ This test method is under the jurisdiction of ASTM Committee D13 on Textiles and is the direct responsibility of Subcommittee D13.20 on Inflatable Restraints . Current edition approved July 1, 2007-2008. Published August 2007-July 2008. Originally approved in 1999. Last previous edition in 2002 as D 6478-02(2007)

² For referenced ASTM standards, visit the ASTM website, www.astm.org, or contact ASTM Customer Service at service@astm.org. For *Annual Book of ASTM Standards* volume information, refer to the standard's Document Summary page on the ASTM website.

³ Available from ASTM International Headquarters. For 17 Detailed CAD Drawings, Order Adjunct No. ADJD6478. For Videotape-Supplemental Training, Order ADJD6478A.

recorded at specified loads. The total of all the individual volumes recorded at each specified cell is the specific packability of the fabric.

5. Significance and Use

5.1 This test method is useful for determining the specific packability of uncoated and coated airbag fabrics. Fabric packability is an important factor in the design of airbag modules due to their inherent spacial constraints.

5.2 A folded specimen exhibits better specific packability if it occupies a lower total volume at the specified loads compared to another specimen.

5.3 The time required to test one sample (four specimens from the same lot of fabric) is approximately 1.5 h using this test method. Due to the length of time required by this test method to perform a single test, this test method is most suitable for use in design and development analysis or for inclusion in a list of required tests conducted for annual certification of an airbag fabric.

6. Apparatus

6.1 *Tensile Tester*, outfitted with a rigid base to support the specimen box, and a compression foot attached to the load cell with a coupling having adjustment and locking capability to maintain fixed parallel alignment to the base. Tensile tester should be calibrated annually by an independent agency whose results are traceable to the National Institute of Science and Technology (NIST) or other national standards laboratory.

NOTE 1—The frame of the tensile tester can be used as the rigid base if it is a solid metal surface which can support compression loading of 200N without deforming, is perfectly flat, and supports the entire footprint of the specimen box.

6.2 *Apparatus Manufactured in Accordance With Drawings*⁴ (See Fig. 1):

6.2.1 *Rectangular Box*, 100 by 150 ± 0.1mm with 99 by 149 ± 0.1 mm cover plate constructed of transparent polycarbonate material.

6.2.2 *Rectangular Template and Rotary Cutting Pad*, 750 by 800 mm ± 0.5 mm, for cutting specimens from fabric samples (optional).

6.2.3 *Jig*, consisting of two sets of slats (wide and narrow) for making the folds and a frame that holds the slats in position during folding.

6.2.4 *Compression Gage Blocks*, with thickness of 10, 20 and 30 ± 0.1 mm.

6.2.5 All dimensions shall be verified at time of manufacture using measuring devices traceable to the National Institute of Science and Technology (NIST) or other national standards laboratory.

6.3 *Rotary Razor Cutter*.

6.4 *Large Paperclips (Three)*, preferably with a serrated surface to improve gripping capability.

6.5 *Permanent Marking Pen*, pen with fine tip.

7. Specimen Preparation

7.1 Condition fabric samples for a minimum of 3 h in the standard atmosphere for testing textiles in accordance with Practice D 1776.

7.2 Without fraying or fusing the edges, cut four 750 by 800 ± 5 - mm specimens from each sample, with the 800 mm dimension aligned in the warp direction and the cuts aligned with the warp and weft yarns in the fabric.

7.3 Write the fabric sample identification and the specimen number on the lower right corner of the specimen (warp yarns running up/down and weft yarns running right/left relative to the operator) at a location about 50 mm from the bottom edge and 50 mm from the right edge.

8. Procedure

8.1 *Tensile Tester Set-Up and Calibration Check*:

8.1.1 Set tensile tester for compression mode, install load cell with maximum force rating of 200 to 1000N, set crosshead speed to 25.0 ± 1.0 mm/min, set data acquisition equipment to record thickness with an accuracy of 0.1 mm at loads of 20 to 180N in 20N increments (nine total points), set sampling frequency at ≥ 25 Hz and set test endpoint at 200N

8.1.2 Mount the rigid base to the tensile tester frame, mount the coupling to the load cell, and attach the compression foot to the coupling, leaving the adjustment locking mechanism loose. (See Note 1)

8.1.3 Lower the crosshead slowly until 200 ± 50N force is achieved and lock the compression foot into position.

8.1.4 Raise the crosshead until there is a gap of approximately 1mm between the compression foot and the base and visually check for parallel alignment in both directions.

8.1.5 Raise the crosshead, place the specimen box on the tensile tester base, and insert the top cover plate into the box.

⁴ Equipment designed by AlliedSignal Performance Fibers, is manufactured according to drawing #61-27A-7906-2 and is available from Precision Machine Company, Inc., 2915 West Lehigh Street, Richmond, VA 23230. Copyright for CAD drawings held by AlliedSignal and provided to ASTM with full unlimited authorization to distribute copies and/or to designate other parties to distribute copies.

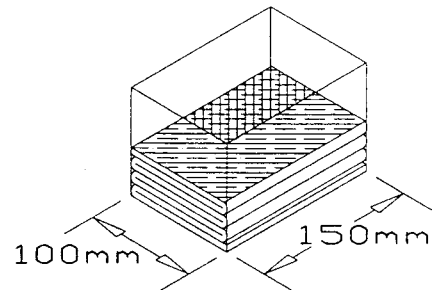
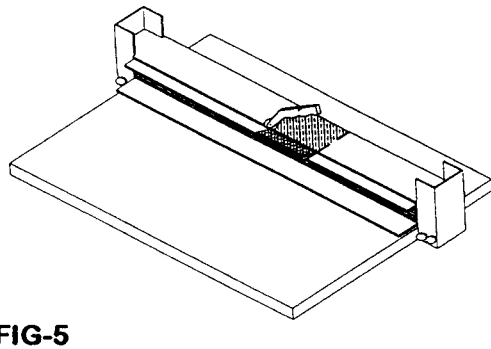
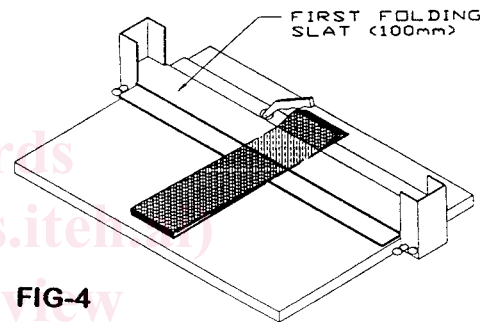
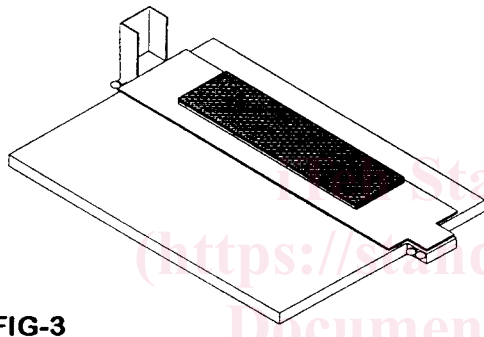
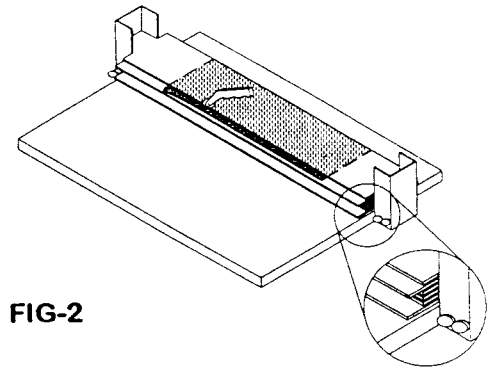
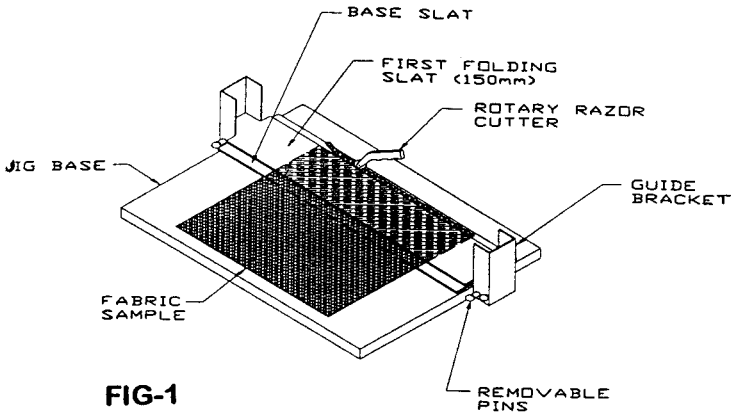

FIG. 1 Apparatus

8.1.6 Raise the specimen box by hand until the compression foot is inside the box, then lower the crosshead and box together until the box rests on the support base and the compression foot is not touching the cover plate. Position the box so that the compression foot is in the approximate center of the box.

NOTE 2—Exercise caution to avoid possible operator injury from the pinch-point between the compression foot and the specimen box.

8.1.7 Lower the crosshead until a force of $100 \pm 30N$ is achieved and set zero.

NOTE 3—An alternate zero can be used to simplify the test. To use the alternate zero, set the true zero as specified, raise the crosshead to the desired point, and zero the crosshead position again. The position of the alternate zero should be selected such that the compression foot does not touch the cover plate when the fabric specimen is in the box. A position of +35 mm is suitable for most airbag fabrics