



Designation: D 5150 – 92 (Reapproved 1997)^{ε1}

Standard Test Method for Hiding Power of Architectural Paints Applied by Roller¹

This standard is issued under the fixed designation D 5150; the number immediately following the designation indicates the year of original adoption or, in the case of revision, the year of last revision. A number in parentheses indicates the year of last reapproval. A superscript epsilon (ϵ) indicates an editorial change since the last revision or reapproval.

^{ε1} NOTE— Editorial changes were made throughout in September 1997.

1. Scope

1.1 This test method measures the ability of a paint to hide or obscure a surface to which it has been applied by a practical application procedure. This test method covers the use of a paint roller, but the concept is expected to work equally well when the application tool is a paint brush or paint pad.

1.2 The values stated in inch-pound units are to be regarded as the standard. The values given in parentheses are for information only.

1.3 *This standard does not purport to address all of the safety concerns, if any, associated with its use. It is the responsibility of the user of this standard to establish appropriate safety and health practices and determine the applicability of regulatory limitations prior to use.*

2. Referenced Documents

2.1 ASTM Standards:

- D 16 Terminology Relating to Paint, Varnish, Lacquer, and Related Products²
- D 1475 Test Method for Density of Paint, Varnish, Lacquer, and Related Products²
- D 2244 Test Method for Calculation of Color Differences from Instrumentally Measured Color Coordinates²
- D 3924 Specification for Standard Environment for Conditioning and Testing Paint, Varnish, Lacquer, and Related Materials²
- D 3925 Practice for Sampling Liquid Paints and Related Pigmented Coatings²
- E 1347 Test Method for Color and Color-Difference Measurement by Tristimulus (Filter) Colorimetry²

3. Terminology

3.1 Definitions:

3.1.1 *hiding power— n* , the ability of a paint or paint material as used to hide or obscure a surface to which it has been uniformly applied (see Terminology D 16).

4. Summary of Test Method

4.1 The test paint is applied with a roller at a specified spreading rate onto a test chart consisting of a series of light to dark grey stripes. After drying, a second coat is applied in the same manner over half of the chart. After the second coat has dried, both the single- and double-coated areas are evaluated for hiding as judged by the darkest stripe in each area that is completely or almost completely obscured.

5. Significance and Use

5.1 Laboratory hiding power measurements of architectural coatings generally employ blade-type applicators that lay down films of highly uniform thickness. But practical applicators, such as rollers, pads, and brushes, typically apply films that lack uniformity due to incomplete leveling, resulting in the practical hiding power of most paints being less than that measured on films applied with a drawdown blade. This test method simulates practical application procedures and conditions so as to provide an indication of the actual hiding performance obtainable when a paint is applied by an experienced worker. It is not intended to duplicate painting as done by the average consumer.

5.2 Since the rheological characteristics of a paint and its interaction with the applicator are influencing factors, rank order correlation between this test and one done by drawdown might not be obtained.

6. Apparatus

- 6.1 *Balance*, accurate to 0.1 g.
- 6.2 *A Weight/Gallon Cup*, or any other type of pycnometer suitable for determining paint density to 0.1 lb/gal.
- 6.3 *Paint Roller*, 3-in. (75-mm), frame, preferably one per paint to be tested.
- 6.4 *Paint Roller Cover*, 3-in. (75-mm) length, with a short nap ($\frac{3}{16}$ to $\frac{1}{4}$ in. (4.8 to 6.4 mm) constructed from a woven fabric. New unused roller covers are preferred but used roller covers may be used but must be thoroughly cleaned so the

¹ This test method is under the jurisdiction of ASTM Committee D01 on Paint and Related Coatings, Materials, and Applications and is the direct responsibility of Subcommittee D01.42 on Architectural Finishes.

Current edition approved June 15, 1992. Published August 1992. Originally Published as D 5150 – 91. Last previous edition D 5150 – 91.

² *Annual Book of ASTM Standards*, Vol 06.01.

resulting appearance is like a new roller cover. When two or more coatings are being tested with the latter type of roller cover, each should have been used approximately the same number of times and should be well dried out from previous applications.

6.5 Paint Tray.

7. Materials

7.1 *Practical Opacity Charts*—These are smooth surface, sealed paper test charts on which are printed a 6-step series of grey stripes of increasing darkness numbered from 1 to 6. The test area is 6 ft² (5575 cm²). For more complete details see Fig. 1 and the manufacturer's description in the appendix.³



FIG. 1 Practical Opacity Chart in Accordance with Footnote 5 and Appendix X1

7.2 Masking Tape.

8. Sampling and Conditioning

8.1 Sample the material in accordance with Practice D 3925.

8.2 Prior to testing, condition the samples in the standard atmosphere described in Specification D 3924. Make all tests under the same conditions.

9. Procedure

9.1 Determine the weight/gallon of each paint being tested to 0.1 lb in accordance with Test Method D 1475.

NOTE 1—The gallon unit referred to in this test method is the U.S. Gallon.

9.2 Use the following equation to determine the amount of paint required for each coat on 3 ft² of chart area:

$$\text{Grams for 3 ft}^2 (2787 \text{ m}^2) = \frac{1362 \times \text{Paint Density (lb/gal)}}{\text{Desired Spreading Rate (ft}^2/\text{gal)}}$$

³ The sole source of supply of the chart, Leneta Form Cu-1 known to the committee at this time is Leneta Co., 15 Whitney Rd., Mahwah, NJ 07430. If you are aware of alternative suppliers, please provide this information to ASTM Headquarters. Your comments will receive careful consideration at a meeting of the responsible technical committee, which you may attend.

The spreading rate may be either the manufacturer's recommended spreading rate for each paint, or the same spreading rate for all paints under test according to agreement between producer and user. A spreading rate of 450 ft²/gal (11.0 m²/L) is suggested if there is no other preference. Include spreading rate(s) used in the report.

9.3 At a convenient height, tape a test chart with the long direction horizontal, to a surface that is vertical or within 5° of vertical (top sloping away from the operator). The tape should be placed on the vertical, numbered border stripes that are outside the 6 ft² (5575 cm²) test area of the chart.

9.4 Prepare the paint roller for use in the test by the following procedure:

9.4.1 Load the roller cover with paint from the tray by rolling it through paint so that just the nap is submersed (see Fig. 2).

9.4.2 Roll out the loaded cover onto a scrap surface, in an upward and downward motion, within an area no larger than 1-ft (0.3-m) high by the 3-in. (75-mm) width of the roller cover.

9.4.3 Reload the roller cover and roll it out again in the same manner as 9.4.2 and over the same area. Do not increase the area except as necessary to control excess dripping of paint.

9.4.4 Repeat the procedure as necessary until the following conditions are met:

9.4.4.1 Reloading the paint roller cover does not result in increased paint pickup.

9.4.4.2 There is so much paint on the surface being used that the fully-loaded paint roller cover cannot transfer any more paint to the surface.

9.4.5 Now immediately perform the test.

9.5 Load the roller cover fully, just short of dripping and weigh. Either weigh the paint and roller before and after, or the paint and reservoir before and after. Do not weigh the paint on the chart, as even minimal evaporation results in significant inaccuracies. Apply to a small area of the left half of the chart, just to deposit the excess paint. Repeat this step as needed so that enough paint is on the chart for the desired spreading rate as calculated in 9.2. Use the roller to evenly spread the paint over the left half of the chart, reweighing to determine if the paint applied is within ±5 % of that desired. If not, add or remove paint as needed with the roller cover. Do this as quickly as possible to minimize the evaporation of volatiles. For this reason, only one adjustment is permitted and the paint out must be completed within 3 min.

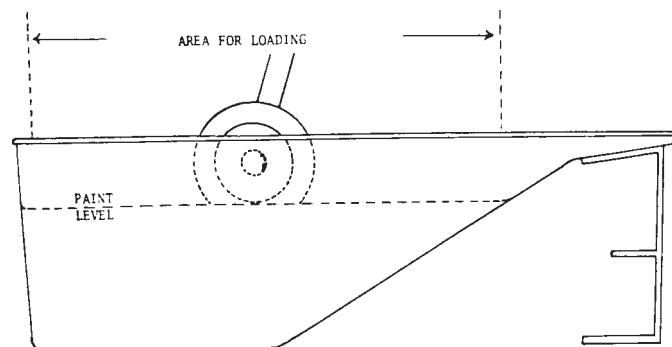

FIG. 2 Loading the Roller