**Imaging materials — Photographic film
and papers — Method for determining
the resistance of photographic
emulsions to wet abrasion**

*Matériaux pour image — Films et papiers photographiques —
Méthode de détermination de la résistance des émulsions
photographiques à l'abrasion dans des conditions humides*

iTeh STANDARD PREVIEW
(standards.iteh.ai)

[ISO 18914:2013](https://standards.iteh.ai/catalog/standards/sist/7a63b4c9-b3aa-46c3-bf32-ff59ad290e9c/iso-18914-2013)

[https://standards.iteh.ai/catalog/standards/sist/7a63b4c9-b3aa-46c3-bf32-
ff59ad290e9c/iso-18914-2013](https://standards.iteh.ai/catalog/standards/sist/7a63b4c9-b3aa-46c3-bf32-ff59ad290e9c/iso-18914-2013)



iTeh STANDARD PREVIEW
(standards.iteh.ai)

ISO 18914:2013

<https://standards.iteh.ai/catalog/standards/sist/7a63b4c9-b3aa-46c3-bf32-f59ad290e9c/iso-18914-2013>



COPYRIGHT PROTECTED DOCUMENT

© ISO 2013

All rights reserved. Unless otherwise specified, no part of this publication may be reproduced or utilized otherwise in any form or by any means, electronic or mechanical, including photocopying, or posting on the internet or an intranet, without prior written permission. Permission can be requested from either ISO at the address below or ISO's member body in the country of the requester.

ISO copyright office
Case postale 56 • CH-1211 Geneva 20
Tel. + 41 22 749 01 11
Fax + 41 22 749 09 47
E-mail copyright@iso.org
Web www.iso.org

Published in Switzerland

Contents

	Page
Foreword	iv
Introduction	v
1 Scope	1
2 Apparatus	1
2.1 Component parts.....	1
2.2 Equipment design.....	1
3 Specimen preparation	3
4 Test method	3
4.1 Procedure.....	3
4.2 Rating.....	4
4.3 Interpretation.....	4
5 Test report	4
Bibliography	5

iTeh STANDARD PREVIEW (standards.iteh.ai)

[ISO 18914:2013](https://standards.iteh.ai/catalog/standards/sist/7a63b4c9-b3aa-46c3-bf32-ff59ad290e9c/iso-18914-2013)

<https://standards.iteh.ai/catalog/standards/sist/7a63b4c9-b3aa-46c3-bf32-ff59ad290e9c/iso-18914-2013>

Foreword

ISO (the International Organization for Standardization) is a worldwide federation of national standards bodies (ISO member bodies). The work of preparing International Standards is normally carried out through ISO technical committees. Each member body interested in a subject for which a technical committee has been established has the right to be represented on that committee. International organizations, governmental and non-governmental, in liaison with ISO, also take part in the work. ISO collaborates closely with the International Electrotechnical Commission (IEC) on all matters of electrotechnical standardization.

International Standards are drafted in accordance with the rules given in the ISO/IEC Directives, Part 2.

The main task of technical committees is to prepare International Standards. Draft International Standards adopted by the technical committees are circulated to the member bodies for voting. Publication as an International Standard requires approval by at least 75 % of the member bodies casting a vote.

Attention is drawn to the possibility that some of the elements of this document may be the subject of patent rights. ISO shall not be held responsible for identifying any or all such patent rights.

ISO 18914 was prepared by Technical Committee ISO/TC 42, *Photography*.

This second edition cancels and replaces the first edition (ISO 18914:2002), of which it constitutes a minor revision with the following changes:

- the contact information contained in footnote 1 has been updated;
- the original footnotes 2 and 4 have been removed and the remaining footnotes have been reidentified;
- Annex A has been removed.

iTeh STANDARD PREVIEW
(standards.iteh.ai)
ISO 18914:2013
<https://standards.iteh.ai/catalog/standards/sist/7a63b4c9-b3aa-46c3-bf32-ff59ad290e9c/iso-18914-2013>

Introduction

If the gelatin emulsion of photographic materials is rubbed against any stationary part of a processing machine, it may be damaged by abrasion during processing. Abrasion can also occur when film or paper is processed in a tray by hand, as the gelatin layers are soft enough to be gouged by foreign particles, corners, or fingernails.

Photographic emulsions are usually more susceptible to abrasions when wet than when dry. Wet emulsions and gelatin backing are also more susceptible to abrasion than the support materials. The test method in this International Standard is applicable only to such wet emulsions or gelatin layers. For dry scratch resistance, see^[1] in the Bibliography.

Photographic emulsions and gelatin layers show physical changes with time. The resistance of these layers to wet abrasion depends on the inherent properties built in at manufacture. It also varies with the treatment received in the dry state prior to processing, such as temperature and moisture content during storage.

The susceptibility to abrasion during processing depends not only on the inherent characteristics of the emulsion, but also on the types of processing solutions, temperatures, and immersion times (see^[2] in the Bibliography for descriptions). In determining emulsion resistance to abrasion, these factors are to be carefully controlled.

The results of wet abrasion, or mushiness, tests are most significant if consideration is given to the final usage of the particular material. For instance, some films are viewed while wet, although usually films and photographic prints are dried prior to viewing or other use. Some materials may show less abrasion damage when examined after drying than when examined wet. The most appropriate rating method is to be chosen and clearly stated in the results.

The test method in this International Standard provides an excellent means of comparing emulsions of different ages, types, processing solutions, processing immersion times, and temperatures, as well as the effects of post-processing treatments. However, many factors are involved in the equipment and technique in either continuous, tank, or tray processing which cannot be considered in a test procedure. Analysis of abrasion resistance in a particular processing system can only be made in the processing system under consideration.

This test method has also been used to measure the change in the physical integrity of the gelatin-emulsion layer after normal or accelerated ageing. For this purpose, the wet abrasion (mushiness) is measured when the emulsion is immersed in distilled water.

iTeh STANDARD PREVIEW
(standards.iteh.ai)

ISO 18914:2013

<https://standards.iteh.ai/catalog/standards/sist/7a63b4c9-b3aa-46c3-bf32-ff59ad290e9c/iso-18914-2013>

Imaging materials — Photographic film and papers — Method for determining the resistance of photographic emulsions to wet abrasion

1 Scope

This International Standard specifies a laboratory test method for determining the resistance of photographic emulsions or gelatin backings to abrasion damage during processing.

This method may be used to determine the effects of variations in processing solutions, gelatin layer properties, processing solution temperatures and times, or a combination of these factors, on the wet scratch resistance of gelatin layers.

This method is applicable to the determination of the physical integrity of photographic emulsions when wet, but it is not applicable to the evaluation of the scratch resistance of the support material.

2 Apparatus

2.1 Component parts

The apparatus shall consist of the following elements:

- a specimen tray in which the specimen can be immersed in either distilled water or a processing solution. The tray shall be free to move smoothly in a horizontal plane for a distance of at least 30 mm without sideways displacement and may be either manually operated or power driven;
- a spherical sapphire or diamond stylus¹⁾ mounted at the end of a pivoted arm, so that it can be lowered onto the specimen and thereby scribe a line on it when the specimen tray travels along under the stylus. The stylus shall make perpendicular contact with the specimen in the tray containing the solution. A 0,38 mm radius stylus should be used for emulsions on photographic film base and a 0,20 mm radius stylus for emulsions on photographic paper base. The stylus arm shall be counterbalanced so that, when the stylus arm is lowered and the stylus rests on the emulsion surface, there is no load on the stylus.

NOTE 1 It is very important that the stylus is smooth and has a uniform radius. Although diamond styli have low friction properties in the dry state, they are satisfactory in this wet application. Diamond styli will wear better than sapphire in high usage circumstances. Diamond styli that have been satisfactory are those compounded from diamond particles.

NOTE 2 The test apparatus for dry scratch resistance, described in ISO 18922, may be modified for this test.

2.2 Equipment design

2.2.1 General

The equipment may be constructed in either of two formats.

1) Sapphire styli may be obtained from a lapidary company, such as the Moser Jewel Company, 518 State Route 57, Phillipsburg, NJ 08865, USA, or a supplier of photographic equipment. Diamond styli compounded from diamond particles can be obtained from Bruce Diamond Corp., 1231 County St., Attleboro, MA 02703, USA. This information is given for the convenience of users of this International Standard and does not constitute an endorsement by ISO of these products.

2.2.2 Constant load instrument

In the constant load instrument, weights are added directly to a pan and the apparatus shall be designed so that the centre of gravity of the weights will be positioned directly over the stylus. These weights should range from 1 g to 210 g. The arm may be pivoted on a threaded hinge with a knurled knob, or other provision for positioning the stylus laterally, so that many parallel scribe lines can be made on the same specimen. As an alternative, the specimen holder can be provided with lateral positioning and a simple pivot used on the stylus arm.

2.2.3 Continuous load instrument

Alternatively, the continuous load instrument (illustrated in [Figure 1](#)) can be used²⁾. As the arm is lowered, the sliding weight is engaged by the carriage so that, when the sliding carriage with the tray is moved away from the fulcrum of the arm, the weight slides with it. This produces an increasing weight on the stylus point as the tray moves with the carriage. This weight increases from 0 g to 70 g, as the carriage moves its full travel of 180 mm. To increase the range of the apparatus, additional weights of 50 g, 100 g, and 150 g can be screwed onto the threaded rod directly over the stylus.

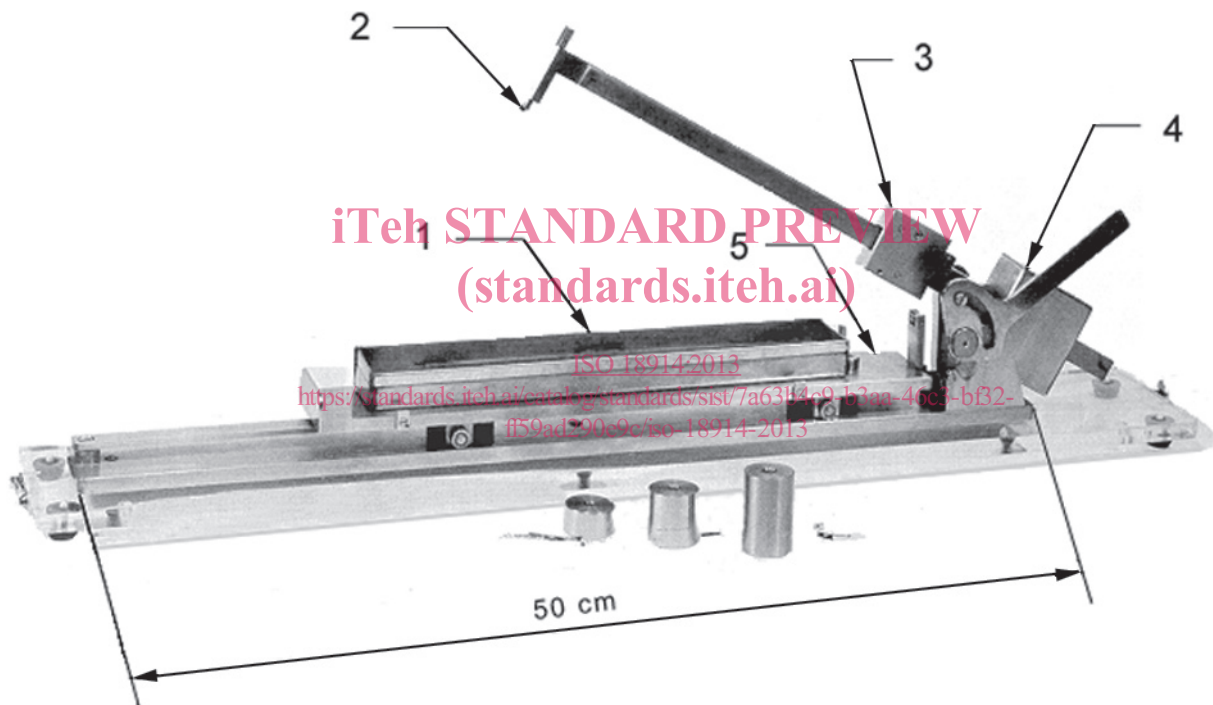

Key

- 1 tray containing 35 mm × 50 mm film sample
- 2 stylus
- 3 sliding weight
- 4 counterweight
- 5 sliding carriage

Figure 1 — Test apparatus for mushiness

The constant load or the continuous load equipment should be made of corrosion-resistant steel or another non-rusting material, so that it may be submerged in water for cleaning.

2) If detailed drawings are required for the construction of this apparatus, they may be purchased through the ISO/TC 42 Secretariat.

A glass plate should be placed in the bottom of the tray to provide a smooth, flat surface under the test specimen.

3 Specimen preparation

Wet abrasion resistance or mushiness can be determined on either unprocessed, processed clear, or processed D_{\max} specimens. The specimens shall be representative of the material being evaluated.

Specimen sizes shall be 35 mm wide by approximately 250 mm long. If narrower specimen widths are to be tested, the dimensions of the tray shall be modified accordingly.

4 Test method

4.1 Procedure

The specimen shall be placed in the tray on top of a glass plate with the surface to be tested placed in the uppermost position. The tray should have projecting ledges on the inside to hold the specimen flat, but these should not interfere with the area touched by the stylus. Processing solution or distilled water shall be added to the tray.

In the constant load instrument, the stylus shall be lowered by the hand lever after the appropriate processing time.

NOTE 1 To avoid tying up the instrument, a specimen may be immersed in the appropriate solution in a separate tray and then transferred to the equipment for evaluation.

The specimen tray shall be drawn forward with the stylus riding in contact with the surface of the specimen. The tray shall be moved at a speed, such that it shall complete its travel in 1 s to 2 s. Three scratch lines, at least 30 mm long, shall be made at each load, spaced approximately 6 mm apart. (A set of four lines may be used occasionally to index the lines according to load). The load range shall be varied to suit the material under test.

NOTE 2 If processing times are short, it may be possible to make only two passes under the stylus without changing the immersion time significantly. If hot processing solutions are used, it may be necessary to warm the tray to the processing temperature before adding the processing solution in order to maintain temperatures.

If the continuous load instrument (see [Figure 1](#)) is used, the position of the stylus shall be marked on the test specimen prior to movement of the tray. The distance that the tray moves is directly proportional to the load on the stylus caused by the sliding weight.

If no evidence of abrasion can be seen by transmitted light, additional weights shall be added to the threaded rod above the stylus until abrasion occurs. The total weight on the stylus is the sum of this additional weight and that caused by the sliding weight. The maximum weight added to the stylus shall be 150 g. Three scratch lines shall be made for each specimen.

To test a specimen in a solution that is one of a sequence of processing solutions, the specimen shall be immersed in each of the preceding processing solutions for the appropriate processing times before being placed in the solution in which abrasion is to be evaluated. For example, an emulsion being tested in wash water should receive its usual developing, fixing, etc. prior to being placed in the wash water for abrasion by the stylus.

NOTE 3 If very short immersion times are to be maintained in a sequence of solutions, it may be necessary to bring the tray to temperature, insert the specimen, and then place the small tray containing the specimen in a larger tray of each solution at the desired processing temperature. At the proper stage in the process, the small tray containing solution and specimen is removed from the larger tray and placed on the instrument for pulling under the stylus.