



Designation: ~~D4395-04~~ Designation: D 4395 - 08

## Standard Test Method for Determining the In Situ Modulus of Deformation of Rock Mass Using the Flexible Plate Loading Method<sup>1</sup>

This standard is issued under the fixed designation D 4395; the number immediately following the designation indicates the year of original adoption or, in the case of revision, the year of last revision. A number in parentheses indicates the year of last reapproval. A superscript epsilon ( $\epsilon$ ) indicates an editorial change since the last revision or reapproval.

### 1. Scope\*

1.1 This test method covers the preparation, equipment, test procedure, and data reduction for determining in situ modulus of deformation of a rock mass using the flexible plate loading method.

1.2 This test method is designed to be conducted in an adit or small underground chamber; however, with suitable modifications it could be conducted at the surface.

1.3 This test method is usually conducted parallel or perpendicular to the anticipated axis of thrust, as dictated by the design load.

1.4 Time-dependent tests not covered by this standard can be performed but are to be reported in another standard.

1.5 All observed and calculated values shall conform to the guidelines for significant digits and rounding established in Practice D 6026.

1.5.1 The method used to specify how data are collected, calculated, or recorded in this standard is not directly related to the accuracy to which the data can be applied in design or other uses, or both. How one applies the results obtained using this standard is beyond its scope.

~~1.6 The values stated in inch-pound units are to be regarded as the standard.~~

1.6 The values stated in inch-pound units are to be regarded as standard. The values given in parentheses are mathematical conversions to SI units that are provided for information only and are not considered standard.

1.7 The references appended to this standard contain further information on this test method.

1.8 *This standard does not purport to address all of the safety concerns, if any, associated with its use. It is the responsibility of the user of this standard to establish appropriate safety and health practices and determine the applicability of regulatory limitations prior to use.* For specific precaution statements, see Section 8.

### 2. Referenced Documents

2.1 *ASTM Standards:*<sup>2</sup>

D 653 Terminology Relating to Soil, Rock, and Contained Fluids

~~D 2113 Practice for Diamond Core Drilling for Site Investigation~~ Practice for Rock Core Drilling and Sampling of Rock for Site Investigation

D 3740 Practice for Minimum Requirements for Agencies Engaged in the Testing and/or Inspection of Soil and Rock as Used in Engineering Design and Construction

D 4394 Test Method for Determining the In Situ Modulus of Deformation of Rock Mass Using the Rigid Plate Loading Method

D 4403 Practice for Extensometers Used in Rock

D 4879 Guide for Geotechnical Mapping of Large Underground Openings in Rock

D 5079 Practices for Preserving and Transporting Rock Core Samples

D 5434 Guide for Field Logging of Subsurface Explorations of Soil and Rock

D 6026 Practice for Using Significant Digits in Geotechnical Data

D 6032 Test Method for Determining Rock Quality Designation (RQD) of Rock Core

### 3. Terminology

3.1 For terminology used in this test method, refer to Terminology D 653.

3.2 *Definitions of Terms Specific to This Standard:*

<sup>1</sup> This test method is under the jurisdiction of ASTM Committee D18 on Soil and Rock and is the direct responsibility of Subcommittee D18.12 on Rock Mechanics. Current edition approved Jan. 1, 2004. Published February 2004. Originally approved in 1984. Last previous edition approved in 1998 as ~~D4395-84(1998)~~ D 4395 - 04.

<sup>2</sup> For referenced ASTM standards, visit the ASTM website, www.astm.org, or contact ASTM Customer Service at service@astm.org. For *Annual Book of ASTM Standards* volume information, refer to the standard's Document Summary page on the ASTM website.

\*A Summary of Changes section appears at the end of this standard.

3.2.1 *deflection*—movement of the plate, mortar pad, or rock in response to and in the same direction as the applied load.

3.2.2 *flexible plate*—theoretically, a plate having no stiffness.

3.2.3 *load*—total force acting on the rock face.

3.2.4 *peak-to-peak modulus of deformation*—the slope of stress - strain curve line connecting the peaks of the curves obtained from successive pressure cycles (see Fig. 1).

3.2.5 *recovery modulus of deformation*—the tangent modulus of the unloading stress - strain curve. This modulus is usually higher than the other moduli and is used in calculations where unloading conditions exist. The difference between the tangent and recovery moduli indicates the material's capacity of hysteresis or energy dissipation capabilities (see Fig. 2).

3.2.6 *secant modulus of deformation*—the slope of the stress - strain curve between zero stress and any specified stress. This modulus should be used for complete load steps from zero to the desired load (see Fig. 2).

3.2.7 *tangent modulus of deformation*—the slope of the stress - strain curve obtained over the segment of the loading curve judged as the most representative of elastic response by the investigator. It neglects the end effects of the curve and is better suited to small stress changes. The ratio between the secant modulus and the tangent modulus can be used as a means of measuring the stress damage of the material (see Fig. 2).

#### 4. Summary of Test Method

4.1 Areas on two opposing parallel faces of a test adit are flattened and smoothed.

4.2 A hydraulic loading system consisting of flatjacks, reaction members, and associated hardware is constructed between the two faces and a mortar pad is placed on each face.

4.3 If deflection is to be measured within the rock mass, install extensometer instruments in the rock in accordance with Practice D 4403.

4.4 The two faces are loaded and unloaded incrementally and the deformations of the rock mass at the surfaces and, if desired, within the rock, are measured after each increment. The modulus of deformation is then calculated.

#### 5. Significance and Use

5.1 Results of this type of test method are used to predict displacements in rock mass caused by loads from a structure or from underground construction. It is one of several tests that should be performed. The resulting in situ modulus is commonly less than the elastic modulus determined in the laboratory.

5.2 The modulus is determined using an elastic solution for a uniformly distributed load (uniform stress) over a circular area acting on a semi-infinite elastic medium.

5.3 This test method is normally performed at ambient temperature, but equipment can be modified or substituted for operations at other temperatures.

NOTE 1—The quality of the result produced by this standard is dependent on the competence of the personnel performing it, and the suitability of the equipment and facilities used. Agencies that meet the criteria of Practice D 3740 are generally considered capable of competent and objective testing/sampling/inspection, etc. Users of this standard are cautioned that compliance with Practice D 3740 does not in itself assure reliable results. Reliable results depend on many factors; Practice D 3740 provides a means of evaluating some of those factors.

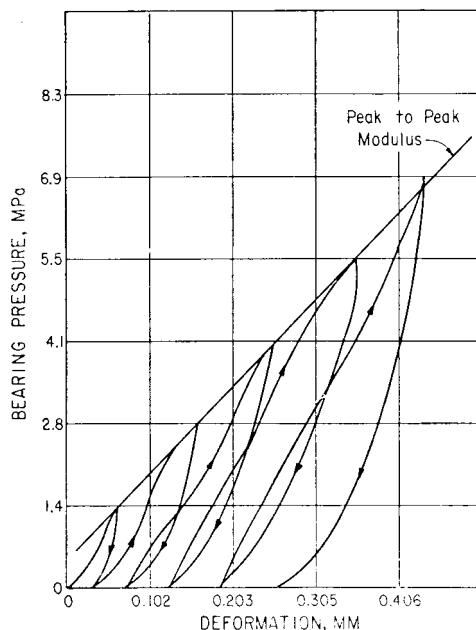
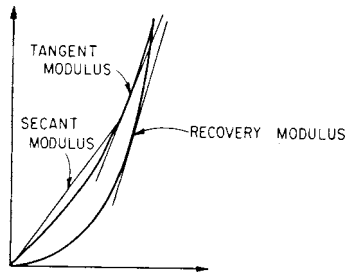

FIG. 1 Rock Surface Deformation as a Function of Bearing Pressure



**FIG. 2 Relationship Between Tangent, Secant, and Recovery Moduli**

## 6. Interferences

6.1 The rock under the loaded area is generally not homogeneous, as assumed in theory. Rock will respond to the load according to its local deformational characteristics. Therefore, deflection measurements at discrete points on the rock surface tend to be heavily influenced by the deformational characteristics of the rock mass at that location and may give results that are unrepresentative of the rock mass. The use of the average plate deflection will mitigate this problem.

6.2 Measurement of the deflection within the rock mass can utilize a finite gauge length to reflect the average rock mass deformation properties between the measuring points. This approach entails three drawbacks, however. First, the rock mass is tested at very low stress levels unless the measurement points are very close to the rock surface and because of this, the same problems as with surface measurements occur. Tests at low stress levels may give unrealistic modulus values because microfractures, joints, and other discontinuities in the rock are open. Secondly, the disturbance caused by implanting the deflection transducer in the rock mass is difficult to evaluate. The techniques in this test method are designed to produce minimal disturbance. Thirdly, in rocks with very high modulus, the accuracy of the instruments may be insufficient to provide reliable results.

6.3 Time-rate of loading has negligible influence on the modulus.

6.4 Calculations neglect the stress history of the rock.

6.5 This test method is insensitive to Poisson's ratio, which must be assumed or obtained from laboratory testing.

## 7. Apparatus

7.1 Equipment necessary for accomplishing this test method includes items for: preparing the test site, drilling and logging the instrumentation holes, measuring the rock deformation, applying and restraining test loads, recording test data, and transporting various components to the test site.

7.2 *Test Site Preparation Equipment*— This should include an assortment of excavation tools, such as drills and chipping hammers. Blasting should not be allowed during final preparation of the test site. The drill for the instrumentation holes should, if possible, have the capability of retrieving cores from depths of at least 30 ft (10 m).

7.3 *Borehole Viewing Device*—Some type of device is desirable for examination of the instrumentation holes to compare and verify geologic features observed in the core if core recovery is poor or if it is not feasible to retrieve oriented cores.

7.4 *Deformation Measuring Instruments*— Instruments for measuring deformations should include a reliable multiple position borehole extensometer (MPBX) for each instrumentation hole and a tunnel diameter gauge. For surface measurements, dial gages, or linear variable differential transformers (LVDTs) are generally used. An accuracy of at least  $\pm 0.0001$  in. (0.0025 mm), including the error of the readout equipment, and a sensitivity of at least 0.00005 in. (0.0013 mm) is recommended. Errors in excess of 0.0004 in. (0.01 mm) can invalidate test results when the modulus of rock mass exceeds  $5 \times 10^6$  psi ( $3.5 \times 10^4$  MPa).

7.5 *Loading Equipment*—The loading equipment includes the device for applying the load and the reaction members (usually thick-walled aluminum or steel pipes) which transmit the load. Flatjacks at each rock face should be used to apply the load and should have sufficient range to allow for deflection of the rock and maintain pressure to within 3 %. They should be constructed so that the two main plates move apart in a parallel manner over the usable portion of the range. A spherical bearing of suitable capacity should be incorporated in the reaction members.

7.6 *Load Measuring Instruments*—A pressure gauge/transducer or load cell should be used to measure the pressure in the flatjacks. The pressure gauge or transducer should have an accuracy of at least  $\pm 20$  psi (0.14 MPa), including error introduced by readout equipment, and a sensitivity of at least 10 psi (0.069 MPa). The load cell should have an accuracy of at least  $\pm 1000$  lbf (4.4 kN) including errors introduced by the readout system, and a sensitivity of at least 500 lbf (2.22 kN) is recommended.

7.7 *Bearing Pads*—The bearing pad material shall have a modulus no greater than the modulus of the rock being tested, as determined from an intact sample. Generally, a neat cement grout is satisfactory if the curing time does not exceed several days. Fly ash or other suitable materials may be added to reduce the stiffness, if necessary.

## 8. Safety Precautions

8.1 All personnel involved in performing the test should be formally pre-qualified in accordance with the quality assurance procedures of Annex A1.

8.2 Verify the compliance of all equipment and apparatus with the performance specifications in Section 7. If no requirements are stated, the manufacturer’s specifications for the equipment may be appropriate as a guide, but care must be taken for sufficient performance. Performance verification is generally done by calibrating the equipment and measurement system. Accomplish calibration and documentation in accordance with Annex A1.

8.3 Enforce safety by applicable safety standards. Pressure lines must be bled of air to preclude violent failure of the pressure system. Total deformation should not exceed the expansion capabilities of the flatjacks; normally this is approximately 3 % of the diameter of a metal flatjack.

**9. In Situ Conditions**

NOTE 2—The guidelines presented in this section are the domain of the agency or organization requesting the testing and are intended to facilitate definition of the scope and development of site-specific requirements for the testing program as a whole.

9.1 Test each structurally distinctive zone of rock mass selecting areas that are geologically representative of the mass. Test those portions of the rock mass with features such as faults, fracture zones, cavities, inclusions, and the like to evaluate their affects. Design the testing program so that affects of local geology can be clearly distinguished.

9.2 The size of the plate will be determined by local geology, pressures to be applied, and the size of the adit to be tested. These parameters should be considered prior to excavation of the adit. Optimum adit dimensions are approximately six times the plate diameter; recommended plate diameter is commonly 1½ to 3¼ ft (0.5 to 1 m). Other sizes are used depending upon site specifics.

9.3 The affectseffects of anisotropy should be investigated by appropriately oriented tests: for example, parallel and perpendicular to the bedding of a sedimentary sequence, or parallel perpendicular to the long axes of columns in a basalt flow.

9.4 Tests should be performed at a site not affected by structural changes resulting from excavations of the adit. The zone of rock that contributes to the measured deflection during the plate loading test depends on the diameter of the plate and the applied load. Larger plates and higher loads measure the response of rock further away from the test adit. Thus, if the rock around the adit is damaged by the excavation process, and the deformational properties of the damaged zone are the primary objective of the test program, small-diameter plate tests on typically excavated surfaces are adequate. If the undisturbed in situ modulus is desired, larger diameter plates and higher loads may be used, although practical considerations often limit the size of the equipment. Alternatively, careful excavation procedures, such as presplitting or other types of smooth-wall blasting, may be employed in the test area to limit damage to the rock and the resulting need for larger plates and loads.

9.5 Cores, if any, should be logged and tested for rock quality designation (RQD), fracture spacing, strength, and deformation in accordance with Guide D 5434 and Test Method D 6032.

9.6 Site conditions may dictate that site preparation and pad construction be performed immediately after excavation.

**10. Procedure**

10.1 A schematic of an optimum test setup is shown on Fig. 3. A properly located wooden platform (not shown) allows for ease of construction and alignment of all test components.

10.2 Conduct the test across a “diameter” or chord of the adit with the two test bearing surfaces mutually parallel and in planes oriented perpendicular to the thrust of the loading assembly.

10.3 *Bearing Surface Preparation :*

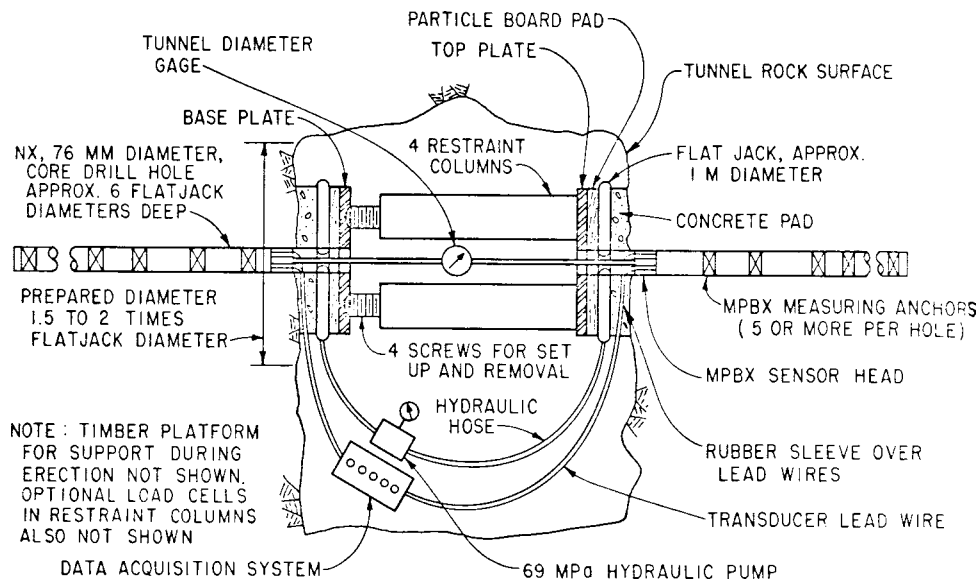

**FIG. 3 Typical Flexible Plate Bearing Test Setup Schematic**

10.3.1 *Method*—Prepare the surface by a method that will cause minimal damage to the finished rock face. Drilling may be required to reach uniform depth. Residual rock between the drill holes may be removed by burnishing or moving the bit back and forth until a smooth face is achieved. Alternatively, in hard, competent rock, controlled blasting with very small charges may be required to remove the residual materials. In softer materials, coarse grinding or cutting devices may be used.

10.3.2 *Size*—The prepared rock surface should extend at least one-half the diameter of the flatjack beyond the edge of the jack during the test.

10.3.3 *Rock Quality*—Prepare the bearing surface in sound rock. Remove loose and broken rock from the excavation. Deeper breaks may be detected by a dull hollow sound when the rock surface is struck with a hammer; remove such material.

10.3.4 *Smoothness*—The prepared rock face should be as smooth as practicable. In no case should the deviation from a plane between the highest and lowest points exceed 1 in. (25 mm).

10.3.5 *Cleaning*—After the surface has been prepared, scrub and rinse it with clean water to remove any loose particles or dirt caused by the smoothing operation.

10.4 Map the geology of the test bearing surfaces and test site, both in plan and cross-section. Guide D 4879 shall be followed when appropriate.

10.5 *Bearing Pad Construction*—Construct the bearing pad, with the flatjack in position, by pouring the pad material between the rock surface and the jack. Contain the pad material by suitable formwork around the edges of the jack. The only exception to this method is for near vertical tests where cement pads are used. In this case, the lower flatjack may be placed directly upon the pad prior to curing. It is recommended that a thin (approximately ½ in. (13 mm)) particle board (wood chips and resin) or other suitable material fabricated to accommodate the flatjack configuration on one side and the plate on the other side be placed between the flatjack and the plate. In all cases, exercise care to avoid air pockets or other cavities within the pad. The thickness of the pad should be no more than 1.5 in./ft (38 mm/0.305 m) of flatjack diameter at any point. The dimensional requirements are shown in Fig. 4.

10.6 *Measuring Points:*

10.6.1 *Surface Measurements*—Take deformation measurements on the rock surface at the edge of the bearing pad at a minimum of six equally spaced intervals around the edge of each pad. If measurements are made on the rock at the center of the loaded area using an annular flatjack, take them at a minimum of three equally spaced positions around the edge of the opening of the annulus. Secure reference pads to the rock surface at surface measurement points. Support the displacement transducers so that only the deflection of the rock itself is measured. Generally, this means mounting the transducers from supports located outside the zone of influence of the test. In no case should the transducers be mounted on the loading apparatus. Install cross tunnel measurement points and equipment such as described in Practice D 4403.

10.6.2 *Measurements Within the Rock Mass:*

10.6.2.1 If deformation measurements in the rock mass itself are required they should be taken along a line within 5° of the direction of loading and located no farther from the center line than 10 % of the width of the bearing pad.

10.6.2.2 The holes for instruments should be as small as feasible. Holes should be diamond-rotary drilled on opposing surfaces and continuously cored and logged. In lieu of specific drilling requirements, Practice D 2113 shall be considered the minimum requirements. Drill core may need to be preserved for laboratory testing in accordance with Practices D 5079. All pertinent drill hole data shall be added to the geologic maps.

10.6.2.3 Select the location of each measurement point by examining the rock core and inspecting the borehole with a borescope or other suitable device. Place the measuring points on either side of joints, thin beds, seams, and the like. Place at least two measuring points within one flatjack diameter of the rock surface. Locate the deepest two measuring points at least six flatjack diameters from the bearing surface to be outside the calculated zone of measured influence. Other instrument arrangements may be appropriate for specific geologic conditions or project objectives.

10.6.2.4 The installation of recording procedures for the measuring instruments or extensometers are presented in Practice D 4403. The extensometer leads extend out from the hole and exit out the side of the bearing pad. Prior to casting the pads, shield the leads with polyvinyl chloride or rubber tubing.

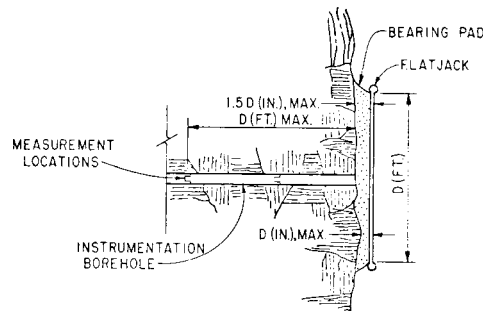

**FIG. 4 Allowable Dimensions for Rock Surface and Bearing Pad, Flexible Plate Loading Test**

10.7 *Pretest Check*—Electronically or mechanically check all components of the instrumentation after they are installed in the drill holes. After the loading and restraining components are installed, make another check of the instrumentation. Make final checks of all mechanical, hydraulic, and electronic components after the concrete pads are placed and again before the first load increment is applied.

10.8 *Pressurization Cycles:*

10.8.1 Observations during the first pressure cycle can be used to modify time rate requirements for successive cycles.

10.8.2 In general, five pressure cycles to peak pressure, each in ten increments at 1 min per increment, should be conducted. The middle cycle should be approximately at design load with the upper cycle approximately two times design load, if possible. The cycles need not be uniformly spaced. The unloading phase should be at the same rate, holding at zero load until creep has stabilized. Take deflection readings after each load increment and decrement. Maintain the peak and zero pressures for each cycle for at least 10 min, with deflection readings taken at 5-min intervals. A typical five-cycle loading sequence is shown in Fig. 1.

10.8.3 Time restrictions may require modifications of the foregoing procedures. At the least, peak pressures must be held for at least 10 min.

10.8.4 If required, both instantaneous deformation and primary creep can be obtained from this test method. Fig. 5 shows a time deformation relationship with incremental loading.

10.8.5 *Data*—Record the data shown on the example form in Fig. 6 and plot the displacement data at each load increment as show in Fig. 7 as a minimum for each test.

11. Calculation

11.1 These equations are based on the elastic solution for uniformly distributed load (constant stress) over a circular area acting on a semi-infinite isotropic elastic medium.<sup>3</sup> The deflection is always defined as the movement in the same direction as the applied load.

11.1.1 *Calculations of the Modulus of Deformation, E*—Calculate the modulus, *E*, from the deflection at the center of a circularly loaded area at the rock surface as follows:

$$E = \frac{2(1 - \nu^2)QR}{W_c} \tag{1}$$

(https://standards.iteh.ai)  
Document Preview

<sup>3</sup> The derivations to these equations are found in: Timoshenko, S., and Goodier, J. N., *Theory of Elasticity*, McGraw-Hill, New York, 1951.

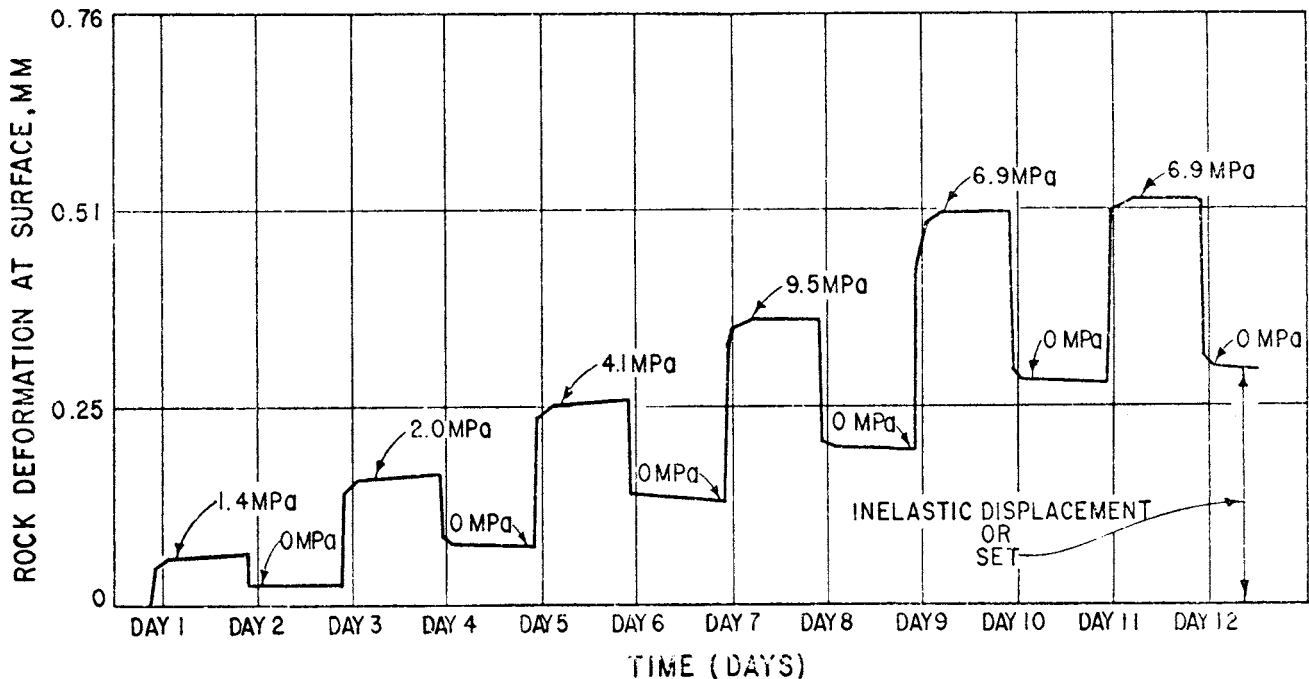

FIG. 5 Rock Deformation at Surface Versus Time