



Standard Practice for Selection and Application of Thermal Insulation for Piping and Machinery¹

This standard is issued under the fixed designation F 683; the number immediately following the designation indicates the year of original adoption or, in the case of revision, the year of last revision. A number in parentheses indicates the year of last reapproval. A superscript epsilon (ϵ) indicates an editorial change since the last revision or reapproval.

This standard has been approved for use by agencies of the Department of Defense.

1. Scope

1.1 This practice provides guidance in the selection of types and thicknesses of thermal insulation materials for piping, machinery, and equipment for nonnuclear shipboard applications. Methods and materials for installation, including lagging, are also detailed.

1.2 Supplemental requirements and exceptions to the requirements discussed herein for ships of the U.S. Navy are included in Supplementary Requirements S1.

1.3 Asbestos or asbestos-containing materials shall not be used.

1.4 The values stated in inch-pound units are to be regarded as the standard. The values given in parentheses are for information only.

1.5 *This standard does not purport to address all of the safety concerns, if any, associated with its use. It is the responsibility of the user of this standard to establish appropriate safety and health practices and determine the applicability of regulatory limitations prior to use.*

2. Referenced Documents²

2.1 ASTM Standards:³

A 167 Specification for Stainless and Heat-Resisting Chromium-Nickel Steel Plate, Sheet, and Strip

A 653/A 653M Specification for Steel Sheet, Zinc-Coated (Galvanized) or Zinc-Iron Alloy-Coated (Galvannealed) by the Hot-Dip Process

B 209 Specification for Aluminum and Aluminum-Alloy Sheet and Plate

B 209M Specification for Aluminum and Aluminum-Alloy Sheet and Plate ~~(Metric)~~ (Metric)

C 168 Terminology Relating to Thermal Insulation

C 195 Specification for Mineral Fiber Thermal Insulating Cement

C 449/C 449M Specification for Mineral Fiber Hydraulic-Setting Thermal Insulating and Finishing Cement ~~(F683-08)~~

C 533 Specification for Calcium Silicate Block and Pipe Thermal Insulation

C 534 Specification for Preformed Flexible Elastomeric Cellular Thermal Insulation in Sheet and Tubular Form

C 547 Specification for Mineral Fiber Pipe Insulation

C 552 Specification for Cellular Glass Thermal Insulation

C 553 Specification for Mineral Fiber Blanket Thermal Insulation for Commercial and Industrial Applications

C 610 Specification for Molded Expanded Perlite Block and Pipe Thermal Insulation

C 612 Specification for Mineral Fiber Block and Board Thermal Insulation

C 680 Practice for ~~Determination~~ Estimate of the Heat Gain or Loss and the Surface Temperatures of Insulated Pipe-Flat, Cylindrical, and Equipment/Spherical Systems by the Use of a Computer Programs

C 892 Specification for High-Temperature Fiber Blanket Thermal Insulation

C 1482 Specification for Polyimide Flexible Cellular Thermal and Sound Absorbing Insulation

D 962 Specification for Aluminum Powder and Paste Pigments for Paints ~~D3400~~ Specification for Liquid Sodium Silicates

F 1138 Specification for Spray Shields for Mechanical Joints

¹ This practice is under the jurisdiction of ASTM Committee F25 on Ships and Marine Technology and is the direct responsibility of Subcommittee F25.02 on Insulation/Processes.

Current edition approved ~~Dec. May 1, 2003-2008~~. Published ~~January 2004~~ July 2008. Originally approved in 1980. Last previous edition approved in 2003 as F 683 - 03a.

² The latest revision of all referenced documents shall apply.

³ For referenced ASTM standards, visit the ASTM website, www.astm.org, or contact ASTM Customer Service at service@astm.org. For *Annual Book of ASTM Standards* volume information, refer to the standard's Document Summary page on the ASTM website.

2.2 Federal Specifications:⁴

HH-P-31 Packing and Lapping Material, Fibrous Glass Metallic and Plain Cloth and Tape
 TT-P-28 Paint, Aluminum, Heat Resisting (1200°F)

2.3 Military Specifications:⁵

~~DoD-C-15328~~Primer (Wash), Pretreatment (Formula No. 117 for Metals) Metric Military Specifications:⁴
~~DoD-C-24596~~MIL-PRF-24596 Coating Compounds, Nonflaming, Fire-Protective (Metric)
 DoD-E-24607 Enamel, Interior, Nonflaming (Dry), Chlorinated Alkyd Resin, Semigloss (Metric)
 DoD-I-24688 Type I, Insulation, Polyimide, Sheet and Tube
 MIL-A-3316 Adhesive, Fire-Resistant, Thermal Insulation
 MIL-A-24179 Adhesive, Flexible, Unicellular-Plastic, Thermal Insulation
 MIL-C-2861 Cement Insulation, High Temperature
 MIL-C-19565 Coating Compounds, Thermal Insulation Pipe Covering—Fire and Water-Resistant Vapor Barrier and Weather Resistant
 MIL-C-20079 Cloth, Glass, Tape, Textile Glass and Thread, Glass
 MIL-C-22395 Compound, End Sealing, Thermal Insulation Pipe Covering—Fire, Water, and Weather Resistant
 MIL-DTL-24441 Paint, Epoxy-Polyamide, Green Primer, Formula 150, Type III
 MIL-I-22023 Insulation Felt, Thermal and Sound Absorbing Felt, Fibrous Glass, Flexible
 MIL-I-2781 Insulation, Pipe, Thermal
~~MIL-I-2818~~Insulation Blanket, Thermal, Fibrous Material MIL-PRF-2818 Insulation Blanket, Thermal
~~MIL-I-2819~~MIL-PRF-2819 Insulation, Block, Thermal
 MIL-I-16411 Insulation, Felt, Thermal, Glass Fiber
~~MIL-I-22344~~Insulation, Pipe, Thermal, Fibrous Glass
MIL-PRF-22344 Insulation, Pipe, Thermal
 MIL-P-15280 Plastic Material, Unicellular (Sheets and Tubes)
MIL-PRF-32161 Insulation, High Temperature Fire Protection, Thermal and Acoustic
 MIL-STD-769 Thermal Insulation Requirements for Machinery and Piping
 MIL-STD-2118 Trap, Steam, Angle, Thermostatic

2.4 Other Documents:

Title 46 Code of Federal Regulations (CFR), Shipping (Parts 164.009 and 164.012)⁴
 Electric Boat Specification 4013 Anti-Sweat and Refrigerant Insulation (Sheet and Tubes)⁵
USCG Type Approval 164.109 IMO FTP Code Annex 1, Part 1⁶
USCG Type Approval 164.112 IMO FTP Code Annex 1, Parts 2 and 5⁶

2.5 Drawings, NAVSHIP:

804-5959214 Piping Insulation, Installation Details⁷ ASTM F683-08
 804-5959212 Machinery Insulation, Installation Details⁷ 28504ac9-c70b-4127-8b21-71838fbc25/astm-f683-08

2.6 NAVSEA:

Naval Ships Technical Manual, Chapter 635—Thermal, Fire, and Acoustic Insulation⁴
 803-5184182 Passive Fire Protection Insulation⁴

3. Terminology

3.1 *Definitions*—For definitions of terms relating to insulating materials used in this practice, refer to Terminology C 168.

4. Materials and Manufacture

4.1 *Insulation and Lapping Material Specifications*, as listed in Tables 1-17, describe those materials that are intended for use in the indicated temperature ranges. The specifications and requirements outlined herein are not intended to prevent the use of new test methods or materials, provided that sufficient technical data is submitted to demonstrate that the proposed test method or material is equivalent in quality, effectiveness, durability, and safety to that prescribed by this practice.

5. General Requirements

5.1 Piping, including valves, fittings, and flanges conveying vapors, gases, or liquids that attain temperatures outside the range from 55 to 125°F (13 to 52°C) during normal operation, shall be insulated except as otherwise stated herein.

⁴ Withdrawn.

⁴ Available from Standardization Documents Order Desk, Bldg. 4 Section D, 700 Robbins Ave., Philadelphia, PA 19111-5094, Attn: NPODS.

⁵ Available from Standardization Documents Order Desk, Bldg. 4 Section D, 700 Robbins Ave., Philadelphia, PA 19111-5094, Attn: NPODS.

⁵ Available from Electric Boat Corp., 75 Eastern Point Rd., Groton, CT 06340.

⁶ Available from Electric Boat Corp., 75 Eastern Point Rd., Groton, CT 06340.

⁶ Available from International Maritime Organization, London, United Kingdom

⁷ Available from U.S. Government Printing Office.

TABLE 1 Insulation and Lagging Materials for Pipe, Tubing, and Fittings Used for Interior Piping Systems^{A,B}

Temperature Range °F (°C)	Insulation	Specification	Lagging ^C	Specification
-20 to +40 (-29 to +4)	cellular glass	C 552, Type II	fibrous glass cloth	MIL-C-20079, Type I, Classes 3 through 9 commercial
	polyimide foam ^D	C 1482, Type I, with vapor retarder	sheet steel galvanized fibrous glass cloth	MIL-C-20079, Type I, Classes 3 through 9
	elastomeric foam plastic ^A	MIL-P-15280, Form T	fibrous glass cloth	MIL-C-20079, Type I, Classes 3 through 9
41 to 125 (5 to 51)	cellular glass	C 552, Type II	fibrous glass cloth	MIL-C-20079, Type I, Classes 3 through 9 commercial
	polyimide foam	C 1482, Type I, with vapor retarder	sheet steel galvanized fibrous glass cloth	MIL-C-20079, Type I, Classes 3 through 9
	elastomeric foam plastic ^A	MIL-P-15280, Form T	fibrous glass cloth	MIL-C-20079, Type I, Classes 3 through 9
	mineral fiber ^D	C 547, Type II	fibrous glass cloth	MIL-C-20079, Type I, Classes 3 through 9 commercial
			sheet steel galvanized fibrous glass cloth	MIL-C-20079, Type I, Classes 3 through 9
126 to 450 (52 to 232)	cellular glass	C 552, Type II	sheet steel galvanized fibrous glass cloth	MIL-C-20079, Type I, Classes 3 through 9 commercial
	polyimide foam ^E 400°F (204°C) max	C 1482, Type I	fibrous glass cloth	MIL-C-20079, Type I, Classes 3 through 9
	elastomeric foam plastic ^A 180°F (82°C) max	MIL-P-15280, Form T	fibrous glass cloth	MIL-C-20079, Type I, Classes 3 through 9 commercial
	calcium silicate	C 533	sheet steel galvanized fibrous glass cloth	MIL-C-20079, Type I, Classes 3 through 9 commercial
	expanded perlite	C 610	sheet steel galvanized fibrous glass cloth	MIL-C-20079, Type I, Classes 3 through 9 commercial
			sheet steel galvanized fibrous glass cloth	MIL-C-20079, Type I, Classes 3 through 9 commercial
451 to 1050 (233 to 566)	cellular glass, 800°F (427°C) max	C 552, Type II	sheet steel galvanized fibrous glass cloth	MIL-C-20079, Type I, Classes 3 through 9 commercial
	mineral fiber	C 547, Class 2 (850°F [454°C] max) or Class 3	sheet steel galvanized sheet steel black	commercial
	calcium silicate	C 533	sheet steel black	commercial
	expanded perlite	C 610	sheet steel black	commercial

^A See 5.4.

^B Insulation and lagging materials are acceptable for the temperature ranges indicated; other materials are capable of being used provided the requirements of this practice are satisfied. Thermal insulating tape is capable of being used as allowed by Section 8 of this practice.

^C Lagging shall be used over insulation only.

^D See Supplementary Requirements S1.5.

^E See Supplementary Requirements S1.15.

5.2 The insulation thicknesses specified in this practice are designed to maintain the surface temperature at or below 125°F (52°C) for fluid temperatures up to 650°F (343°C) with an ambient temperature of 85°F (29°C). For fluid temperatures above 650°F, the surface will be maintained at a maximum of 133°F (56°C).

5.2.1 Insulation thicknesses have been calculated in accordance with the computer programs in Practice C 680.

5.3 Piping and units of equipment with designated internal temperatures of 300°F (149°C) and over shall be insulated from their supports or the supports insulated from the structures to which they are attached where the heat transmitted is objectionable on the opposite side of the structure.

5.4 ~~Insulated piping passing through accommodation, service, and control spaces must be covered with approved incombustible materials which meet 46 CFR, Sections 164.009 and 164.012. Elastomeric foam plastic insulation shall not be used in these spaces.~~ Insulated piping passing through accommodation, service, and control spaces must be covered with approved noncombustible materials, which meet 46 CFR, Sections 164.009 and 164.012, or USCG Type Approval 164.109 and 164.112 as issued by the USCG. Elastomeric foam plastic insulation shall not be used in these spaces.

5.5 Special consideration shall be given to the insulation of integral piping supplied with and mounted on equipment or machinery. In these cases, alternative materials and methods of installation shall be considered provided that they comply with the performance requirements of this practice.

5.6 Minimum insulation requirements have not been established for those surfaces or applications in which insulations had not been specified in past practices. In effect, the following surfaces are excluded from insulation requirements:

5.6.1 Surfaces where application of insulation will affect proper operation.

5.6.2 Equipment, components, and systems designed for the dispersion of heat.

5.6.3 Thermostatic steam traps and 24 in. (620 mm) of piping upstream of traps, which shall not be insulated. When located in areas in which personnel protection is required, expanded metal shields or multilayer glass cloth shall be provided.

5.6.4 Mechanical joints exposed to subatmospheric pressures and those included in the fuel oil service piping from heaters to burners.

TABLE 2 Insulation and Lagging Materials for Pipe, Tubing, and Fittings Used for Weather-Exposed Piping Systems^A

Temperature Range ° F (°C)	Insulation	Specification	Lagging ^B	Specification
-20 to +40 (-29 to +4)	cellular glass	C 552, Type II	fibrous glass cloth	MIL-C-20079, Type I Class 7 (fittings) Class 9 (piping)
	polyimide foam	C 1482, Type I, with vapor retarder	fibrous glass cloth	MIL-C-20079, Type I Class 7 (fittings) Class 9 (piping)
	perlite	C 610	fibrous glass cloth	MIL-C-20079, Type I Class 7 (fittings) Class 9 (piping)
	<u>elastomeric foam plastic</u>	<u>MIL-P-15280, Form T</u>	<u>corrosion resistant steel</u>	<u>A 167, Type 304</u>
	<u>elastomeric foam plastic</u>	<u>MIL-P-15280, Form T</u>	<u>fibrous glass cloth</u>	<u>MIL-C-20079, Type I, Classes 3 through 9</u>
41 to 100 (5 to 37)	cellular glass	C 552, Type II	corrosion-resistant steel	A 167, Type 304
	polyimide foam	C 1482, Type I, with vapor retarder	fibrous glass cloth	MIL-C-20079, Type I Class 7 (fittings) Class 9 (piping)
	perlite	C 610	corrosion-resistant steel	A 167, Type 304
	calcium silicate	C 533	corrosion-resistant steel	A 167, Type 304
	mineral fiber ^C	C 547, Class 2 or 3	corrosion-resistant steel	A 167, Type 304
	<u>elastomeric foam plastic</u>	<u>MIL-P-15280, Form T</u>	<u>corrosion resistant steel</u>	<u>A 167, Type 304</u>
	<u>elastomeric foam plastic</u>	<u>MIL-P-15280, Form T</u>	<u>fibrous glass cloth</u>	<u>MIL-C-20079, Type I, Classes 3 through 9</u>
101 to 450 (38 to 232)	cellular glass	C 552, Type II	corrosion-resistant steel	A 167, Type 304
	polyimide foam ^B 400°F (204°C) max	C 1482, Type I	corrosion-resistant steel	A 167, Type 304
	perlite	C 610	corrosion-resistant steel	A 167, Type 304
	calcium silicate	C 533	corrosion-resistant steel	A 167, Type 304
	mineral fiber ^C	C 547, Class 2 or 3	corrosion-resistant steel	A 167, Type 304
	<u>elastomeric foam plastic</u>	<u>MIL-P-15280, Form T</u>	<u>corrosion-resistant steel</u>	<u>A 167, Type 304</u>
	<u>180°F (82°C) Max</u>			
	<u>elastomeric foam plastic</u>	<u>MIL-P-15280, Form T</u>	<u>fibrous glass cloth</u>	<u>MIL-C-20079, Type I, Classes 3 through 9</u>
<u>180°F (82°C) Max</u>				

^A Insulation and lagging materials listed are acceptable for the temperature ranges indicated; other materials are capable of being used provided the requirements of this practice are satisfied.

^B See Supplementary Requirements S1.15.

^C See Supplementary Requirements S1.5.

5.6.5 Fuel oil piping between headers and burners.

5.6.6 Piping above 125°F (52°C) in bilges, not within watertight enclosures.

5.6.7 Piping in locations in which sweating and resultant rust is not objectionable such as voids, bilges, and shaft alleys, plus plumbing fixtures and associated supply and drain piping immediately adjacent thereto.

5.6.8 Deadend hot water piping 3/8 in. (10 mm) and smaller.

5.6.9 Pressure-gage piping.

5.6.10 Soot-blower valve units and soot-blower flanges.

5.6.11 Piping in voids and cofferdams except where omitting insulation is detrimental to system operation, such as catapult steam.

5.6.12 Safety valve bodies, springs, and lifting gear.

5.6.13 Piping over shower stalls and behind and under lavatories.

5.6.14 Valves or flanges in the collection holding tank (CHT) system.

5.7 Higher-temperature-type insulations are capable of being used where lower-temperature-type insulations are specified, provided that they are satisfactory in all other respects.

5.8 In “high traffic” locations in which the completed insulation and lagging is liable to abuse, such as shipping, unshipping, and maintenance areas, protective sheet metal lagging shall be installed. Where metal lagging is required, any of the materials listed

TABLE 3 Insulation and Lagging Materials for Machinery and Equipment^{A, B}

Temperature Range °F (°C)	Insulation	Specification	Lagging	Specification
-20 to +40 (-29 to +4)	elastomeric foam plastic ^A	MIL-P-15280, Form S	fibrous glass cloth	MIL-C-20079, Type I, Classes 3 through 9
	polyimide foam	C 1482, Type I	fibrous glass cloth with vapor retarder	MIL-C-20079 Type I, Classes 3 through 9
	cellular glass	C 552, Type II	sheet steel galvanized	commercial ^C
41 to 125 (5 to 51)	elastomeric foam plastic ^A	MIL-P-15280, Form S	fibrous glass cloth	MIL-C-20079, Type I, Classes 3 through 9
	polyimide foam	C 1482, Type I	fibrous glass cloth with vapor retarder	MIL-C-20079, Type I, Classes 3 through 9
	cellular glass	C 552, Type I	fibrous glass cloth, or sheet steel black commercial	MIL-C-20079, Type I, Classes 3 through 9 commercial ^C
	mineral fiber blanket	C 553	sheet steel black, commercial or fibrous glass cloth with vapor retarder	MIL-C-20079, Type I, Classes 3 through 9 commercial ^C
126 to 1200 (52 to 649)	fibrous glass felt	MIL-I-16411, Type II	fibrous glass cloth glass wire, reinforced	MIL-C-20079, Type I, Classes 7 or 9 HH-P-31, Type I
	polyimide foam ^D 400°F (204°C) max	C 1482, Type I	fibrous glass cloth	MIL-C-20079, Type I, Classes 3 through 8
	refractory fiber blanket	C 892, Grade 6 or 8	sheet steel black commercial or fibrous glass cloth glass wire, reinforced	MIL-C-20079, Type I, Classes 3 through 9 HH-P-31, Type I
	elastomeric foam plastic (180°F [82°C] max)	MIL-P-15280 sheet	fibrous glass cloth	MIL-C-20079, Type I, Classes 3 through 9
	high-temperature insulating cement ^E	C 195		
	calcium silicate insulating block	C 553		
	mineral fiber blanket (1000°F [538°C] max)	C 553, C 612	sheet steel black, or fibrous glass cloth glass wire, reinforced	MIL-C-20079, Type I, Classes 3 through 9 HH-P-31, Type I
	perlite	C 610	fibrous glass cloth	MIL-C-20079, Type I, Classes 3 through 9

^A See 5.4.

^B Insulation and lagging materials are acceptable for the temperature ranges indicated; other materials are capable of being used provided the requirements of this practice are satisfied.

^C With or without rewettable adhesive.

^D See Supplementary Requirements S1.15.

^E When insulating cement is used, it shall be applied in successive layers, ½ to 1 in. (13 to 25 mm) in thickness, until the total thickness specified in Table 7 has been reached. Galvanized iron wire netting, 1-in. (13-mm) mesh, shall be installed between layers. A ½-in. (13-mm) thickness of finishing cement, in accordance with Specification C 449/C 449M, shall be applied over the last layer of insulating cement.

in Table 13 are acceptable, except for boiler uptake applications in which metal lagging shall be galvanized sheet steel, in accordance with Specification A 653/A 653M, with Coating Designation G-115, and not less than 1/32 in. (0.8 mm) thick.

5.9 Before installing insulation, surface preparation of the piping is to be accomplished in accordance with the ship's painting schedule.

5.10 Lacing hooks shall be welded to the structure or equipment (with permission of the vendor of the equipment) for securing insulation to the equipment.

5.11 For bends, fittings, and so forth, where molded sections of pipe insulation cannot be used, mitered sections of the pipe insulation or premolded fittings and covers shall be used, provided that they are suitable for the temperature and that the requirements of this practice are satisfied (see 4.1 and 5.4). Fittings in sizes under 2-in. (51-mm) nominal pipe size (NPS) shall be insulated with insulating cement, in accordance with Specification C 449/C 449M.

5.12 Where insulation specifications listed in Tables 1 and 3 provide for the use of nonmetal "jacketed"-type insulation, separate lagging material shall be omitted.

5.13 Single-layered insulation construction shall be permitted on all surfaces operating at temperatures below 600°F (316°C).

TABLE 4 Thickness of Cellular Glass Insulation for Piping, –20 to 800°F (–29 to 427°C)^A

Nominal Pipe Size, in. (mm)	Maximum Temperature, °F (°C) × Thickness, in. (mm)								
	–20 to 40 ^B (–29 to 4)	41 to 125 ^C (5 to 52)	250 (121)	350 (177)	450 (232)	550 (288)	650 (343)	750 (399)	850 (454)
¼ (6) and above	2½ (63) 1½ ^D (38)	1 (25) ½ ^D (13)
1½ (38) and below	1 (25)	1 (25)	1½ (38)	2 (51)	2½ (63)	2½ (63)	3 (76)
2 (51)	1 (25)	2 (51)	1½ (38)	2 (51)	3 (76)	3 (76)	3½ (89)
2½, 3 (63, 76)	1 (25)	1½ (38)	2 (51)	2½ (63)	3 (76)	3½ (89)	4 (102)
4 (102)	1 (25)	1½ (38)	2 (51)	2½ (63)	3½ (89)	3½ (89)	4 (102)
5, 6 (127, 152)	1 (25)	1½ (38)	2 (51)	3 (76)	3½ (89)	3½ (89)	4½ (114)
8 (203)	1½ (38)	1½ (38)	2 (51)	3 (76)	3½ (89)	4 (102)	5 (127)
10 (254)	1½ (38)	1½ (38)	2 (51)	3 (76)	4 (102)	4 (102)	5 (127)
12 (305)	1½ (38)	1½ (38)	2½ (63)	3 (76)	4 (102)	4½ (114)	5½ (140)
14 (356)	1½ (38)	1½ (38)	2½ (63)	3½ (89)	4 (102)	4½ (114)	5½ (140)
16 (406)	1½ (38)	1½ (38)	2½ (63)	3½ (89)	4½ (114)	4½ (114)	5½ (140)
18 (457)	1½ (38)	1½ (38)	2½ (63)	3½ (89)	4½ (114)	4½ (114)	5½ (140)

^A Thickness of cellular glass, in accordance with Specification C 552, Type II.

^B For refrigerant piping.

^C For antisweat applications.

^D Thickness for applications in air-conditioned spaces only.

TABLE 5 Thickness of Elastomeric Foam Plastic Insulation Piping, –20 to 180°F (–29 to 82°C)^A

Nominal Size, in. (mm)	Temperature Range, °F (°C)	Nominal Thickness, in. (mm)	
		Non-conditioned spaces	Air conditioned spaces only
¼ (6) and above	–20 to 40 (–29 to 4) ^B	1½ (38)	1 (25)
	41 to 125 (5 to 52) ^C	¾ (19)	½ (13)
	126 to 180 (53 to 82)	½ (13)	½ (13)

^A Thickness of elastomeric foam plastic insulation, conforming with MIL-P-15280, Form T.

^B For refrigerant piping.

^C For antisweat applications.

TABLE 6 Thickness of Polyimide Foam Insulation Piping, –20 to 400°F (–29 to 204°C)^A

Nominal Size, in. (mm)	Temperature Range, °F (°C)	Nominal Thickness, in. (mm)	
		Non-conditioned spaces	Air conditioned spaces only
¼ (6) and above	–20 to 40 (–29 to 4) ^B	1½ (38)	1 (25)
	41 to 125 (5 to 52) ^C	¾ (19)	½ (13)
	126 to 180 (53 to 82)	½ (13)	½ (13)
	181 to 250 (83 to 121)	¾ (19)	¾ (19)
	251 to 350 (122 to 177)	1 (25)	1 (25)
	351 to 400 (178 to 204)	1½ (38)	1½ (38)

^A Thickness of polyimide foam insulation conforming with Specification C 1482.

^B For refrigerant piping.

^C For antisweat applications.

Double-layered insulation construction shall be used with all joints staggered on all surfaces operating at temperatures of 600°F and above, except single-layered construction will be permitted when the total insulation thickness is 3 in. (75 mm) or less or the pipe size is NPS 2 in. (50 mm) or below.

6. Selection Requirements, Piping

6.1 *Interior Piping, Temperature Range from –20 to +40°F (–29 to +4°C)*—Use for air conditioning and ship's stores refrigerant piping and other services within the temperature range.

6.1.1 For insulation and lagging materials, see Table 1.

TABLE 7 Thickness of Mineral Fiber Insulation for Hot Piping, 850°F (454°C) Maximum^{A,B}

Nominal Pipe Size, in. (mm)	Maximum Temperature, °F (°C) × Thickness, in. (mm)							
	150 (66)	250 (121)	350 (177)	450 (232)	550 (288)	650 (343)	750 (399)	850 (454)
1½ (38) and below	1 (25)	1 (25)	1 (25)	1½ (38)	2 (51)	2 (51)	2½ (63)	3 (76)
2 (51)	1 (25)	1 (25)	1 (25)	1½ (38)	2 (51)	2½ (63)	3 (76)	3½ (89)
2½, 3 (63, 76)	1 (25)	1 (25)	1 (25)	1½ (38)	2 (51)	3 (76)	3½ (89)	4 (102)
4 (102)	1 (25)	1 (25)	1 (25)	1½ (38)	2 (51)	3 (76)	3½ (89)	4 (102)
5, 6 (127, 152)	1 (25)	1 (25)	1 (25)	2 (51)	2½ (63)	3 (76)	3½ (89)	4 (102)
8 (203)	1 (25)	1 (25)	1 (25)	2 (51)	2½ (63)	3 (76)	3½ (89)	4½ (114)
10 (254)	1 (25)	1 (25)	1½ (38)	2 (51)	2½ (63)	3½ (89)	4 (102)	4½ (114)
12 (305)	1 (25)	1 (25)	1½ (38)	2 (51)	2½ (63)	3½ (89)	4½ (114)	4½ (114)
14, 16, 18 (356, 406, 457)	1 (25)	1 (25)	1½ (38)	2 (51)	3 (76)	3½ (89)	4½ (114)	5 (127)

^A Commercially known as fibrous glass.

^B Thickness of mineral fiber insulation in accordance with Specification C 547, Class 2.

TABLE 8 Thickness of Mineral Fiber Insulation for Hot Piping, 1050°F (566°C) Maximum^{A,B}

Nominal Pipe Size, in. (mm)	Maximum Temperature, °F (°C) × Thickness, in. (mm)									
	150 (66)	250 (121)	350 (177)	450 (232)	550 (288)	650 (343)	750 (399)	850 (454)	950 (510)	1050 (566)
1½ (38) and below	1 (25)	1 (25)	1 (25)	1½ (38)	2 (51)	2 (51)	2 (51)	2½ (63)	3 (76)	3½ (89)
2 (51)	1 (25)	1 (25)	1 (25)	1½ (38)	2 (51)	2½ (63)	2½ (63)	3 (76)	3½ (89)	4 (102)
2½, 3 (63, 76)	1 (25)	1 (25)	1 (25)	1½ (38)	2 (51)	2½ (63)	3½ (89)	3½ (89)	4 (102)	4½ (114)
4 (102)	1 (25)	1 (25)	1 (25)	1½ (38)	2 (51)	2½ (63)	3 (76)	3½ (89)	4 (102)	4½ (114)
5, 6 (127, 152)	1 (25)	1 (25)	1½ (38)	2 (51)	2½ (63)	3 (76)	3 (76)	3½ (89)	4½ (114)	5½ (140)
8 (203)	1 (25)	1 (25)	1½ (38)	2 (51)	2½ (63)	3 (76)	3 (76)	4 (102)	4½ (114)	5½ (140)
10 (254)	1 (25)	1 (25)	1½ (38)	2 (51)	2½ (63)	3 (76)	3½ (89)	4 (102)	5 (127)	6 (152)
12 (305)	1 (25)	1 (25)	1½ (38)	2 (51)	2½ (63)	3½ (89)	3½ (89)	4 (102)	5 (127)	6 (152)
14 (356)	1 (25)	1 (25)	1½ (38)	2 (51)	2½ (63)	3½ (89)	3½ (89)	4½ (114)	5½ (140)	6½ (165)
16 (406)	1 (25)	1 (25)	1½ (38)	2 (51)	3 (76)	3½ (89)	3½ (89)	4½ (114)	5½ (140)	6½ (165)
18 (457)	1 (25)	1 (25)	1½ (38)	2 (51)	3 (76)	3½ (89)	4 (102)	4½ (114)	5½ (140)	6½ (165)

^A Commercially known as mineral wool.

^B Thickness of mineral fiber insulation, in accordance with Specification C 547, Class 3.

TABLE 9 Thickness of Calcium Silicate Insulation (Specification C 533) for Hot Piping, 1050°F (566°C) Maximum^A

Nominal Pipe Size, in. (mm)	Maximum Temperature, °F (°C) × Thickness, in. (mm)									
	150 (66)	250 (121)	350 (177)	450 (232)	550 (288)	650 (343)	750 (399)	850 (454)	950 (510)	1050 (566)
1½ (38) and below	1 (25)	1 (25)	1 (25)	1½ (38)	2 (51)	2½ (63)	2½ (63)	2½ (63)	3 (76)	3½ (89)
2 (51)	1 (25)	1 (25)	1 (25)	1½ (38)	2 (51)	2½ (63)	2½ (63)	3 (76)	3½ (89)	4 (102)
2½, 3, 4 (63, 76, 102)	1 (25)	1 (25)	1½ (38)	2 (51)	2½ (63)	3 (76)	3 (76)	3½ (89)	4 (102)	5 (127)
5, 6 (127, 152)	1½ (38)	1½ (38)	1½ (38)	2 (51)	2½ (63)	3½ (89)	3½ (89)	4 (102)	4½ (114)	5½ (140)
8 (203)	1½ (38)	1½ (38)	1½ (38)	2 (51)	2½ (63)	3½ (89)	3½ (89)	4 (102)	5 (127)	5½ (140)
10 (254)	1½ (38)	1½ (38)	1½ (38)	2 (51)	3 (76)	3½ (89)	3½ (89)	4½ (114)	5 (127)	6 (152)
12 (305)	1½ (38)	1½ (38)	1½ (38)	2 (51)	3 (76)	3½ (89)	3½ (89)	4½ (114)	5½ (140)	6 (152)
14 (356)	1½ (38)	1½ (38)	1½ (38)	2½ (63)	3 (76)	4 (102)	4 (102)	4½ (114)	5½ (140)	6½ (165)
16, 18 (406, 457)	1½ (38)	1½ (38)	1½ (38)	2½ (63)	3 (76)	4 (102)	4 (102)	5 (127)	5½ (140)	6½ (165)

^A Thickness of calcium silicate insulation, in accordance with Specification C 533.

6.1.2 For insulation thickness, see Table 4 or Table 5.

6.1.3 For installation details, see Fig. 1, Fig. 2, or Fig. 3 as applicable.

 6.2 *Interior Piping, Temperature Range from 41 to 125°F (5 to 52°C)*—Use for cold freshwater, plumbing drains, firemain, main and auxiliary, saltwater circulating, and saltwater cooling, piping, and other services within the temperature range.

6.2.1 For insulation and lagging materials, see Table 1.

6.2.2 For insulation thickness, see Table 2, Table 3, or Table 4.

6.2.3 For installation details, see Fig. 1, Fig. 2, or Fig. 3 as applicable.

 6.2.4 *Special Conditions:*

6.2.4.1 Piping systems operating in this temperature range including water closet drain piping do not require insulation except

TABLE 10 Thickness of Perlite Insulation (Specification C 610) for Hot Piping, 1050°F (566°C) Maximum^A

Nominal Pipe Size, in. (mm)	Maximum Temperature, °F (°C) × Thickness, in. (mm)									
	150 (66)	250 (121)	350 (177)	450 (232)	550 (288)	650 (343)	750 (399)	850 (454)	950 (510)	1050 (566)
1½ (38) and below	1 (25)	1 (25)	1 (25)	1½ (38)	2 (51)	2½ (63)	2½ (63)	2½ (63)	3 (76)	3½ (89)
2 (51)	1 (25)	1 (25)	1 (25)	1½ (38)	2 (51)	2½ (63)	2½ (63)	3 (76)	3½ (89)	4 (102)
2½, 3, 4 (63, 76, 102)	1 (25)	1 (25)	1½ (38)	2 (51)	2½ (63)	3 (76)	3 (76)	3½ (89)	4 (102)	5 (127)
5, 6 (127, 152)	1½ (38)	1½ (38)	1½ (38)	2 (51)	2½ (63)	3½ (89)	3½ (89)	4 (102)	4½ (114)	5½ (140)
8 (203)	1½ (38)	1½ (38)	1½ (38)	2 (51)	2½ (63)	3½ (89)	3½ (89)	4 (102)	5 (127)	5½ (140)
10 (255)	1½ (38)	1½ (38)	1½ (38)	2 (51)	3 (76)	3½ (89)	3½ (89)	4½ (114)	5 (127)	6 (152)
12 (305)	1½ (38)	1½ (38)	1½ (38)	2 (51)	3 (76)	3½ (89)	3½ (89)	4½ (114)	5½ (140)	6 (152)
14 (356)	1½ (38)	1½ (38)	1½ (38)	2½ (63)	3 (76)	4 (102)	4 (102)	4½ (114)	5½ (140)	6½ (163)
16, 18 (406, 457)	1½ (38)	1½ (38)	1½ (38)	2½ (63)	3 (76)	4 (102)	4 (102)	5 (127)	5½ (140)	6½ (165)

^A Thickness of perlite insulation, in accordance with Specification C 610.

TABLE 11 Thickness of Antisweat Insulation for Machinery and Equipment

Temperature Range, °F (°C)	Material Specification	Nominal Thickness, in. (mm) ^A	
		Unconditioned Spaces	Conditioned Spaces
-20 to +40 (-29 to +4)	elastomeric foam plastic, C 534, Type II	2 (51)	1 (25) ^B
	polyimide foam, C 1482, Type I with vapor retarder	2 (51)	1 (25) ^B
41 to 125 (5 to 51)	cellular glass, C 552 Type I	3 (76)	1½ (38) ^B
	elastomeric foam plastic, C 534, Type II	¾ (19)	½ (13) ^B
	polyimide foam, C 1482, Type I with vapor retarder	1 (25)	¾ (19) ^B
	cellular glass, C 552, Type I	1 (25)	½ (13) ^B
	mineral fiber blanket, C 553, C 612	1 (25)	¾ (19) ^B

^A Nominal thickness exclusive of vapor retarder.

^B Thickness for application in air-conditioned spaces only.

TABLE 12 Thickness of Insulating Materials for Hot Surfaces of Machinery and Equipment, 126 to 1200°F (52 to 649°C)

Material	Maximum Temperature, °F (°C) × Thickness, in. (mm) ^A									
	150 (66)	250 (121)	350 (177)	450 (232)	550 (288)	650 (343)	750 (399)	850 (454)	950 (510)	1050 (566)
Fibrous glass felt, MIL-I-16411, Type II	1 (25)	1 (25)	1½ (38)	2½ (63)	3 (76)	4 (102)	4 (102)	5 (127)	5½ (140)	6½ (165)
Block calcium silicate, C 533	1½ (38)	1½ (38)	2 (51)	2½ (63)	4 (102)	4 (102)	4 (102)	5 (127)	5 (127)	5½ (140)
Block perlite, C 610	1½ (38)	1½ (38)	2 (51)	2½ (63)	4 (102)	4 (102)	4 (102)	5 (127)	5 (127)	5½ (140)
Refractory fiber, C 892, Grade 6	1 (25)	1 (25)	2 (51)	2½ (63)	3½ (89)	4½ (114)	4½ (114)	5½ (140)	6 (152)	7½ (191)
Refractory fiber, C 892 Grade 8	1 (25)	1 (25)	1½ (38)	2½ (63)	3 (76)	4 (102)	4 (102)	5 (127)	6 (152)	7 (178)
Mineral fiber, ^B C 553	1½ (38)	1½ (38)	2 (51)	2½ (63)	3½ (89)	3½ (89)	3½ (89)	4 (102)	4½ (114)	5 (127)
Elastomeric foam, ^C C 534, Type II	½ (13)	½ (13)								
Polyimide foam, C 1482 ^D	¾ (19)	1 (25)	1½ (38)	2 (51)						
Insulating cement, ^E C 195	2 (51)	2 (51)	2½ (63)	3½ (89)	5 (127)	5 (127)	5 (127)	5½ (140)		

^A Does not include finishing cement.

^B 1000°F (537°C) maximum temperature.

^C 180°F (82°C) maximum temperature.

^D Shall not be used alone above 850°F (454°C).

^E See Supplementary Requirements S1.15.

where damage or discomfort will result from condensation.

6.2.4.2 Dry firemain need only be insulated above ceilings and in areas in which damage or discomfort from condensation is a problem.

6.2.4.3 If cold, fresh, or potable water tanks (not having a side integral with the shell) are installed in a heated area, the piping to the pumps and therefore to the services need not be insulated. If this water is being used for flushing water closets, the drain piping need not be insulated.

6.2.4.4 Freshwater fill piping inside the ship shall be insulated.

6.2.4.5 Drains from drinking water chillers shall be insulated.

6.3 *Interior Piping, Temperature Range from 126 to 450°F (52 to 232°C)*—Use for hot freshwater, hot-water heating, fuel oil service discharge from heaters to headers, condensate, and air ejector piping, boiler feed, high- and low-pressure steam drain piping, and other services within the temperature range.

6.3.1 For insulation and lagging materials, see Table 1.

TABLE 13 Metal Lagging Materials^A

Material	Specification	Nominal Thickness, in. (mm)
Hot-dipped galvanized steel	A 526/A 526M Coating designation G-115	0.014 (0.356)
Aluminum	B 209, 6061	0.030 (0.762)
Corrosion-resistant steel	A 167, Type 304	0.014 (0.356)

^A For use on piping and machinery insulation in locations where insulation is subject to abuse, except for uptake applications in which metal lagging shall be galvanized steel, Specification A 526/A 526M, Coating Designation G-115, not less than 1/32 in. (0.795 mm) thick.

TABLE 14 Thickness of Fiberglass Felt for Removable Insulation Blankets^A

Nominal Pipe Size, in. (mm)	Maximum Temperature, °F (°C) × Thickness, in. (mm)									
	150 (66)	250 (121)	350 (177)	450 (232)	550 (288)	650 (343)	750 (399)	850 (454)	950 (510)	1050 (566)
1/2 (13)	1 (25)	1 (25)	1 1/2 (38)	1 1/2 (38)	2 (51)	2 (51)	2 1/2 (63)	2 1/2 (63)	3 (76)	3 1/2 (89)
1 (25)	1 (25)	1 (25)	1 (25)	1 1/2 (38)	2 (51)	2 (51)	2 1/2 (63)	3 (76)	3 (76)	3 1/2 (89)
1 1/2 (38)	1 (25)	1 (25)	1 (25)	1 1/2 (38)	2 (51)	2 1/2 (63)	2 1/2 (63)	3 (76)	3 1/2 (89)	4 (102)
2 (51)	1 (25)	1 (25)	1 (25)	1 1/2 (38)	2 (51)	2 1/2 (63)	2 1/2 (63)	3 (76)	3 1/2 (89)	4 (102)
3 (76)	1 (25)	1 (25)	1 (25)	1 1/2 (38)	2 (51)	2 1/2 (63)	3 (76)	3 1/2 (89)	4 (102)	4 1/2 (114)
4 (102)	1 (25)	1 (25)	1 1/2 (38)	2 (51)	2 1/2 (63)	3 (76)	3 (76)	3 1/2 (89)	4 (102)	5 (127)
6 (152)	1 (25)	1 (25)	1 1/2 (38)	2 (51)	2 1/2 (63)	3 (76)	3 (76)	4 (102)	4 1/2 (114)	5 1/2 (140)
8 (203)	1 (25)	1 (25)	1 1/2 (38)	2 (51)	2 1/2 (63)	3 (76)	3 1/2 (89)	4 (102)	5 (127)	5 1/2 (140)
10 (254)	1 (25)	1 (25)	1 1/2 (38)	2 (51)	2 1/2 (63)	3 1/2 (89)	3 1/2 (89)	4 (102)	5 (127)	6 (152)
12 (305)	1 (25)	1 (25)	1 1/2 (38)	2 (51)	2 1/2 (63)	3 1/2 (89)	3 1/2 (89)	4 1/2 (114)	5 (127)	6 (152)
14 (356)	1 (25)	1 (25)	1 1/2 (38)	2 (51)	2 1/2 (63)	3 1/2 (89)	3 1/2 (89)	4 1/2 (114)	5 1/2 (140)	6 (152)
16 (406)	1 (25)	1 (25)	1 1/2 (38)	2 (51)	3 (76)	3 1/2 (89)	3 1/2 (89)	4 1/2 (114)	5 1/2 (140)	6 1/2 (165)
18 (457)	1 (25)	1 (25)	1 1/2 (38)	2 (51)	3 (76)	3 1/2 (89)	4 (102)	4 1/2 (114)	5 1/2 (140)	6 1/2 (165)

^A Thickness of fiberglass felt, in accordance with MIL-I-16411, Type II.

TABLE 15 Thickness of 8-lb/ft³ (128-kg/m³) Refractory Fiber Blanket for Removable Insulation Blankets^A

Nominal Pipe Size, in. (mm)	Maximum Temperature, °F (°C) × Thickness, in. (mm)									
	150 (66)	250 (121)	350 (177)	450 (232)	550 (288)	650 (343)	750 (399)	850 (454)	950 (510)	1050 (566)
1/2 (13)	1 (25)	1 (25)	1 (25)	1 1/2 (38)	1 1/2 (38)	2 (51)	2 (51)	2 1/2 (63)	3 (76)	3 (76)
1 (25)	1 (25)	1 (25)	1 (25)	1 1/2 (38)	2 (51)	2 (51)	2 1/2 (63)	3 (76)	3 (76)	3 1/2 (89)
1 1/2 (38)	1 (25)	1 (25)	1 (25)	1 1/2 (38)	2 (51)	2 1/2 (63)	2 1/2 (63)	3 (76)	3 1/2 (89)	4 (102)
2 (51)	1 (25)	1 (25)	1 (25)	1 1/2 (38)	2 (51)	2 1/2 (63)	2 1/2 (63)	3 (76)	3 1/2 (89)	4 (102)
3 (76)	1 (25)	1 (25)	1 1/2 (38)	2 (51)	2 1/2 (63)	3 (76)	3 (76)	3 1/2 (89)	4 (102)	4 1/2 (114)
4 (102)	1 (25)	1 (25)	1 1/2 (38)	2 (50)	2 1/2 (63)	3 (76)	3 (76)	3 1/2 (89)	4 (102)	4 1/2 (114)
6 (152)	1 (25)	1 (25)	1 1/2 (38)	2 (51)	2 1/2 (63)	3 (76)	3 (76)	4 (102)	4 1/2 (114)	5 (127)
8 (203)	1 (25)	1 (25)	1 1/2 (38)	2 (51)	2 1/2 (63)	3 1/2 (89)	3 1/2 (89)	4 (102)	4 1/2 (114)	5 1/2 (140)
10 (254)	1 (25)	1 (25)	1 1/2 (38)	2 (51)	3 (76)	3 1/2 (89)	3 1/2 (89)	4 (102)	5 (127)	5 1/2 (140)
12 (305)	1 (25)	1 (25)	1 1/2 (38)	2 (51)	3 (76)	3 1/2 (89)	3 1/2 (89)	4 1/2 (114)	5 (127)	6 (152)
14 (356)	1 (25)	1 (25)	1 1/2 (38)	2 (51)	3 (76)	3 1/2 (89)	3 1/2 (89)	4 1/2 (114)	5 (127)	6 (152)
16 (406)	1 (25)	1 (25)	1 1/2 (38)	2 (51)	3 (76)	3 1/2 (89)	3 1/2 (89)	4 1/2 (114)	5 (127)	6 (152)
18 (457)	1 (25)	1 (25)	1 1/2 (38)	2 1/2 (63)	3 (76)	3 1/2 (89)	4 (102)	4 1/2 (114)	5 1/2 (140)	6 (152)

^A Thickness of 8-lb/ft³ (128-kg/m³) refractory fiber blanket in accordance with Specification C 892, Grade 8.

6.3.2 For insulation thickness, see Table 4, Table 5, Table 7, Table 8, or Table 9.

6.3.3 For installation details, see Fig. 1, Fig. 2, Fig. 3, Fig. 4, Fig. 5, or Fig. 6, as applicable.

6.3.4 *Special Conditions*—On piping, tubing, and fittings sized less than NPS 3/8 in., insulation need be applied only where required for personnel protection.

6.4 *Interior Piping, Temperature Range from 451 to 1200°F (233 to 649°C)*—Use for main steam, auxiliary steam, exhaust and bleed steam, gland seal steam and exhaust, high- and low-pressure steam drains, soot blower steam, boiler blow, safety and relief valve escape steam heating, diesel exhaust piping, and other services within the temperature range.

6.4.1 For insulation and lagging materials, see Table 1.

6.4.2 For insulation thickness, see Table 4, Table 7, Table 8, or Table 9, as applicable.

6.4.3 For installation details, see Fig. 1, Fig. 4, Fig. 5, or Fig. 6, as applicable.

6.4.4 *Special Conditions:*

6.4.4.1 The soot blower piping between the root valve and the soot blower heads shall have an insulation thickness of one half of that indicated for a continually operating system at the same temperature.

6.4.4.2 Main steam piping insulation shall be arranged with removable pads to bare sections for audio gaging when required.

6.4.4.3 Turbogenerator exhaust to main and auxiliary condensers do not require insulation except in areas susceptible to personnel contact.

6.4.4.4 Safety and relief valve escape piping need not be insulated except in areas susceptible to contact by personnel.

TABLE 16 Thickness of 6-lb/ft³ (96-kg/m³) Refractory Fiber Blanket for Removable Insulation Blankets^A

Nominal Pipe Size, in. (mm)	Maximum Temperature, °F (°C) × Thickness, in. (mm)									
	150 (66)	250 (121)	350 (177)	450 (232)	550 (288)	650 (343)	750 (399)	850 (454)	950 (510)	1050 (566)
½ (13)	1 (25)	1 (25)	1 (25)	1½ (38)	1½ (38)	2 (51)	2 (51)	2½ (63)	2½ (63)	3 (76)
1 (25)	1 (25)	1 (25)	1 (25)	1½ (38)	2 (51)	2½ (63)	2½ (63)	2½ (63)	3 (76)	3½ (89)
1½ (38)	1 (25)	1 (25)	1½ (38)	1½ (38)	2 (51)	2½ (63)	2½ (63)	2½ (63)	3 (76)	4 (102)
2 (51)	1 (25)	1 (25)	1½ (38)	1½ (38)	2 (51)	2½ (63)	2½ (63)	3 (76)	3½ (89)	4 (102)
3 (76)	1 (25)	1 (25)	1½ (38)	2 (51)	2½ (63)	3 (76)	3 (76)	3½ (89)	4 (102)	4½ (114)
4 (102)	1 (25)	1 (25)	1½ (38)	2 (51)	2½ (63)	3 (76)	3 (76)	3½ (89)	4½ (114)	5 (127)
6 (152)	1 (25)	1 (25)	1½ (38)	2 (51)	2½ (63)	3½ (89)	3½ (89)	4 (102)	4½ (114)	5½ (140)
8 (203)	1 (25)	1 (25)	1½ (38)	2 (51)	2½ (63)	3½ (89)	3½ (89)	4 (102)	5 (127)	5½ (140)
10 (254)	1 (25)	1 (25)	1½ (38)	2 (51)	3 (76)	3½ (89)	3½ (89)	4½ (114)	5 (127)	6 (152)
12 (305)	1 (25)	1 (25)	1½ (38)	2½ (63)	3 (76)	3½ (89)	4 (102)	4½ (114)	5½ (140)	6 (152)
14 (356)	1 (25)	1 (25)	2 (51)	2½ (63)	3 (76)	3½ (89)	4 (102)	4½ (114)	5½ (140)	6½ (165)
16 (406)	1 (25)	1 (25)	2 (51)	2½ (63)	3 (76)	3½ (89)	4 (102)	4½ (114)	5½ (140)	6½ (165)
18 (457)	1 (25)	1 (25)	2 (51)	2½ (63)	3½ (89)	3½ (89)	4 (102)	5 (127)	6 (152)	6½ (165)

^A Thickness of 6-lb/ft³ (96-kg/m³) refractory fiber blanket in accordance with Specification C 892, Grade 6.

TABLE 17 Thickness of Fiberglass Blanket for Removable Insulation Blankets^A

Nominal Pipe Size, in. (mm)	Maximum Temperature, °F (°C) × Thickness, in. (mm)							
	150 (66)	250 (121)	350 (177)	450 (232)	550 (288)	650 (343)	750 (399)	850 (454)
½ (13)	½ (13)	½ (13)	1 (25)	1 (25)	1½ (38)	2 (51)	2½ (63)	3 (76)
1 (25)	½ (13)	½ (13)	1 (25)	1½ (38)	2 (51)	2 (51)	2½ (63)	3 (76)
1½ (38)	½ (13)	½ (13)	1 (25)	1½ (38)	2 (51)	2 (51)	3 (76)	3½ (89)
2 (51)	½ (13)	½ (13)	1 (25)	1½ (38)	2 (51)	2 (51)	3 (76)	4 (102)
3 (76)	½ (13)	½ (13)	1 (25)	1½ (38)	2 (51)	2 (51)	3 (76)	4 (102)
4 (102)	½ (13)	½ (13)	1 (25)	1½ (38)	2½ (63)	2½ (63)	3½ (89)	4½ (114)
6 (152)	½ (13)	½ (13)	1 (25)	2 (51)	2½ (63)	2½ (63)	3½ (89)	5 (127)
8 (203)	½ (13)	½ (13)	1 (25)	2 (51)	2½ (63)	2½ (63)	4 (102)	5 (127)
10 (254)	½ (13)	½ (13)	1½ (38)	2 (51)	2½ (63)	2½ (63)	4 (102)	5½ (140)
12 (305)	½ (13)	1 (25)	1½ (38)	2 (51)	2½ (63)	2½ (63)	4 (102)	5½ (140)
14 (356)	½ (13)	1 (25)	1½ (38)	2 (51)	3 (76)	4 (102)	4 (102)	5½ (140)
16 (406)	½ (13)	1 (25)	1½ (38)	2 (51)	3 (76)	4 (102)	4½ (114)	5½ (140)
18 (457)	½ (13)	1 (25)	1½ (38)	2 (51)	3 (76)	4 (102)	4½ (114)	6 (152)

^A Thickness of fiberglass blanket, in accordance with Specification C 612, Type II, C 553, Type IV.

6.4.4.5 Boiler blow piping need not be insulated except in areas susceptible to contact by personnel.

6.4.4.6 On piping, tubing, and fittings sizes less than NPS ¾ in. (10 mm), insulation need be applied only where required for personnel protection.

6.4.4.7 Steam smothering and steam to the sea chests need be insulated only in those areas susceptible to personnel contact.

6.5 *Weather-Exposed Piping, Temperature Range from -20 to +40°F (-29 to +4°C)*—Use for low-temperature piping exposed to the weather.

6.5.1 For insulation and lagging materials, see Table 2.

6.5.2 For insulation thickness, see Table 4.

6.5.3 For installation details, see Fig. 3, Fig. 7, or Fig. 8.

6.5.4 *Special Conditions:*

6.5.4.1 Piping exposed to the weather shall also be effectively insulated against freezing. The thickness of insulation required to prevent freezing is determined by calculation based on the system fluid, system velocity, type of insulation to be used, and climatic conditions involved. This does not apply to systems that are secured and drained.

6.5.4.2 At pipe supports, remove only enough insulation to provide a snug fit. Fill voids between insulation and support with tightly packed fibrous glass felt, conforming with MIL-I-16411, Type II, to within ¼ in. (6 mm) of the insulation surface. Fill the remainder with end-sealing compound, conforming with MIL-C-22395, overlapping both the support member and the adjacent insulation. Lag and coat with the same materials as the adjacent pipe.

6.5.4.3 Alternatively, the lagged insulation and ends are permitted to be clad with metal lagging in lieu of end sealing compound.

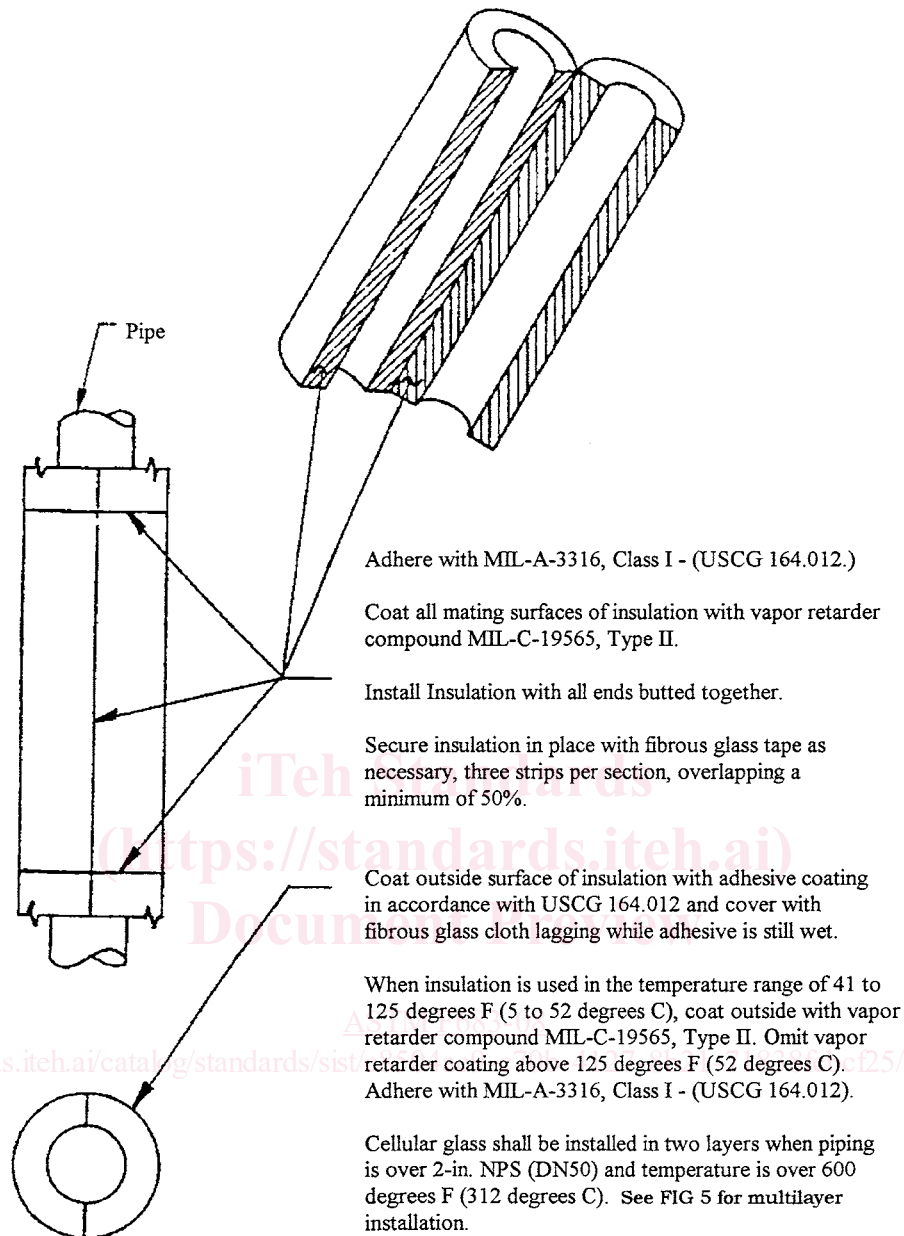

FIG. 1 Installation of Cellular Glass Pipe Insulation (Specification C 552)

6.6 *Weather-Exposed Piping, Temperature Range from 41 to 450°F (5 to 232°C)*—Use for hot piping systems exposed to weather.

6.6.1 For insulation and lagging materials, see Table 2.

6.6.2 For insulation thickness, see Table 4, Table 7, Table 8, or Table 9.

6.6.3 For installation details, see Fig. 3, Fig. 7, or Fig. 8.

6.6.4 *Special Conditions:*

6.6.4.1 Piping exposed to the weather shall be effectively insulated against freezing. The thickness of insulation required to prevent freezing is determined by calculation based on the system fluid, system velocity, type of insulation to be used, and climatic conditions involved. This does not apply to systems that are secured and drained.

6.6.4.2 At pipe supports, remove only enough insulation to provide a snug fit. Fill voids between the insulation and support with tightly packed fibrous glass felt, conforming with MIL-I-16411, Type II, to within ¼ in. (6 mm) of the insulation surface. Fill the remainder with end-sealing compound, conforming with MIL-C-22395, overlapping both the support member and the adjacent insulation. Lag and coat with the same materials as the adjacent pipe.

6.6.4.3 Alternatively, the lagged insulation and ends are permitted to be clad with metal lagging in lieu of end sealing compound.