**Glass in building — Determination of
the bending strength of glass —**

Part 2:

**Coaxial double-ring test on flat
specimens with large test surface areas**

iTeh STANDARD PREVIEW
(standards.iteh.ai)

*Verre dans la construction — Détermination de la résistance du verre
à la flexion —*

*Partie 2: Essais avec doubles anneaux concentriques sur éprouvettes
planes, avec de grandes surfaces de sollicitation*

ISO 1288-2:2016

<https://standards.iteh.ai/catalog/standards/sist/6d940be8-36ad-4a68-ac5d-d37912f91a14/iso-1288-2-2016>



iTeh STANDARD PREVIEW
(standards.iteh.ai)

ISO 1288-2:2016

<https://standards.iteh.ai/catalog/standards/sist/6d940be8-36ad-4a68-ac5d-d37912f91a14/iso-1288-2-2016>



COPYRIGHT PROTECTED DOCUMENT

© ISO 2016, Published in Switzerland

All rights reserved. Unless otherwise specified, no part of this publication may be reproduced or utilized otherwise in any form or by any means, electronic or mechanical, including photocopying, or posting on the internet or an intranet, without prior written permission. Permission can be requested from either ISO at the address below or ISO's member body in the country of the requester.

ISO copyright office
Ch. de Blandonnet 8 • CP 401
CH-1214 Vernier, Geneva, Switzerland
Tel. +41 22 749 01 11
Fax +41 22 749 09 47
copyright@iso.org
www.iso.org

Contents

	Page
Foreword	iv
1 Scope	1
2 Normative references	1
3 Terms and definitions	1
4 Symbols	2
5 Principle of test method	2
6 Apparatus	3
6.1 Testing machine	3
6.2 Loading device	4
6.2.1 Ring load	4
6.2.2 Surface pressure regulator	4
6.3 Measuring instruments	5
7 Sample	5
7.1 Shape and dimensions of the specimens	5
7.2 Sampling and preparation of specimens	5
7.2.1 Cutting and handling	5
7.2.2 Conditioning	5
7.2.3 Examination	6
7.2.4 Adhesive film	6
7.3 Number of specimens	6
8 Procedure	6
8.1 Temperature	6
8.2 Humidity	6
8.3 Thickness measurement	6
8.4 Base plate	6
8.5 Positioning of specimen and loading ring	6
8.6 Load application	7
8.7 Loading rate	7
8.8 Location of the origin	7
8.9 Assessment of residual stresses	7
9 Evaluation	8
9.1 Limitation of the evaluation	8
9.2 Calculation of bending strength	8
10 Test report	9
Annex A (informative) Example of a device for keeping the gas pressure, p, in line with the piston force, F	11
Bibliography	14

Foreword

ISO (the International Organization for Standardization) is a worldwide federation of national standards bodies (ISO member bodies). The work of preparing International Standards is normally carried out through ISO technical committees. Each member body interested in a subject for which a technical committee has been established has the right to be represented on that committee. International organizations, governmental and non-governmental, in liaison with ISO, also take part in the work. ISO collaborates closely with the International Electrotechnical Commission (IEC) on all matters of electrotechnical standardization.

The procedures used to develop this document and those intended for its further maintenance are described in the ISO/IEC Directives, Part 1. In particular the different approval criteria needed for the different types of ISO documents should be noted. This document was drafted in accordance with the editorial rules of the ISO/IEC Directives, Part 2 (see www.iso.org/directives).

Attention is drawn to the possibility that some of the elements of this document may be the subject of patent rights. ISO shall not be held responsible for identifying any or all such patent rights. Details of any patent rights identified during the development of the document will be in the Introduction and/or on the ISO list of patent declarations received (see www.iso.org/patents).

Any trade name used in this document is information given for the convenience of users and does not constitute an endorsement.

For an explanation on the meaning of ISO specific terms and expressions related to conformity assessment, as well as information about ISO's adherence to the WTO principles in the Technical Barriers to Trade (TBT) see the following URL: [Foreword - Supplementary information](#)

The committee responsible for this document is ISO/TC 160, *Glass in building*, Subcommittee SC 2, *Use considerations*

ISO 1288 consists of the following parts, under the general title *Glass in building* — *Determination of the bending strength of glass*:

- *Part 1: Fundamentals of testing glass*
- *Part 2: Coaxial double ring test on flat specimens with large test surface areas*
- *Part 3: Test with specimen supported at two points (four point bending)*
- *Part 4: Testing of channel shaped glass*
- *Part 5: Coaxial double ring test on flat specimens with small test surface areas*

Glass in building — Determination of the bending strength of glass —

Part 2: Coaxial double-ring test on flat specimens with large test surface areas

1 Scope

This part of ISO 1288 specifies a method for determining the bending strength of glass for use in buildings, excluding the effects of the edges.

The limitations of this part of ISO 1288 are described in ISO 1288-1.

2 Normative references

The following documents, in whole or in part, are normatively referenced in this document and are indispensable for its application. For dated references, only the edition cited applies. For undated references, the latest edition of the referenced document (including any amendments) applies.

ISO 48, *Rubber, vulcanized or thermoplastic — Determination of hardness (hardness between 10 IRHD and 100 IRHD)*

ISO 1288-2:2016

ISO 1288-1, *Glass in building — Determination of the bending strength of glass - Part 1: Fundamentals of testing glass*

3 Terms and definitions

For the purposes of this document, the following terms and definitions apply.

3.1

bending stress

tensile bending stress induced in the surface of a specimen

Note 1 to entry: For testing purposes, the bending stress should be uniform over a specified part of the surface.

3.2

effective bending stress

weighted average of the tensile bending stresses, calculated by applying a factor to take into account non-uniformity of the stress field

3.3

bending strength

tensile bending stress or effective bending stress which leads to breakage of the specimen

3.4

equivalent bending strength

apparent bending strength of patterned glass, for which the irregularities in the thickness do not allow precise calculation of the bending stress

4 Symbols

A	effective surface area of quasi-uniform stress	m^2
E	modulus of elasticity (Young's modulus) of the specimen NOTE For soda lime silicate glass (see ISO 16293-1), a value of 70 GPa is used.	Pa
F	piston force	N
F_{\max}	piston force upon breakage, "breaking force"	N
F_{ring}	force transmitted by the loading ring to the specimen, "ring load"	N
h	thickness or average thickness of specimen	m
L	side length of the square specimens	m
μ	Poisson number of specimen NOTE For soda lime silicate glass (see ISO 16293-1), a value of 0,23 is used.	
p	gas pressure on the surface area defined by the loading ring	Pa
$p(F)$	nominal gas pressure as a function of the piston force	Pa
$p_{\max}(F_{\max})$	nominal gas pressure upon breakage	Pa
r	location coordinate	m
r_1	radius of loading ring	m
r_2	radius of supporting ring	m
r_{3m}	average specimen radius (for evaluation)	m
σ	stress	Pa
σ_{bB}	bending strength	Pa
σ_{beqB}	equivalent bending strength	Pa
t	time	s
$\Delta F/\Delta t$	rate at which piston force rises	N/s
F^*, p^*, σ^*	non-dimensional quantities corresponding to F, p and σ [see Formulae (1) to (5)]	

5 Principle of test method

The square specimen, of side length, L , and having virtually plain parallel surfaces, is placed loosely on a supporting ring (a circular ring with a radius r_2). The specimen is subjected to a load, F_{ring} , by means of a loading ring (radius r_1), which is arranged concentrically to the supporting ring. In addition, the area, A , defined by the loading ring $0 < r < r_1$ is placed under gas pressure, p , which has a specific relationship with the ring load, F_{ring} (see [Figure 1](#)).

When the specimen is subjected to the ring load and the associated gas pressure, depending upon the dimensions r_1, r_2, L , and h , a radial tensile stress field, which is sufficiently homogeneous for the test purpose, is developed on the convexly bent surface over the area defined by the loading ring (see References [2], [3], [4]). The tangential tensile stress is equal to the radial tensile stress at the central point ($r = 0$) of the specimen, but decreases as the radius, r , increases.

Outside the loading ring, the radial and tangential stresses fall sharply towards the edge of the specimen, so that the risk of breakage outside the loading ring is low. On the edge of the specimen itself, the radial stress is zero and the tangential stress is a compressive stress, this being the case on both the concavely and the convexly bent sides of the specimen. The edge of the specimen is thus always under tangential compressive stress (see ISO 1288-1).

By increasing the force, F , and the gas pressure, p , the tensile stress in the central part of the specimen is increased at a constant rate [see (6.1 b)] until breakage, so the origin of the break can be expected to occur in the surface area subjected to maximum tensile stress within the loading ring.

With the test apparatus as shown in Figure 1, a force, pA , acts against the piston force, F , due to the gas pressure, p . The force transferred by the loading ring is $F_{\text{ring}} = F - pA$. Thus a distinction should be made between the piston force and the ring load.

The bending strength, σ_{bB} , or equivalent bending strength, σ_{beqB} , is calculated from the maximum value, F_{max} , of the piston force, measured at the time of breakage, and the thickness, h , of the specimen, taking into account the prescribed dimensions of the specimen and various characteristic material values. This assumes that the gas pressure, p , follows the piston force, F , according to the nominal function $p(F)$, (see Figure 3).

6 Apparatus

6.1 Testing machine

The bending test shall be carried out using a suitable bending testing machine, which shall incorporate the following features.

- The stressing of the specimen shall be capable of being applied from zero up to a maximum value in a manner which minimizes shock and is stepless.
- The stressing device shall be capable of the specified rate of stressing.
- The testing machine shall incorporate a load measuring device with a limit of error of $\pm 2,0\%$ within the measuring range.

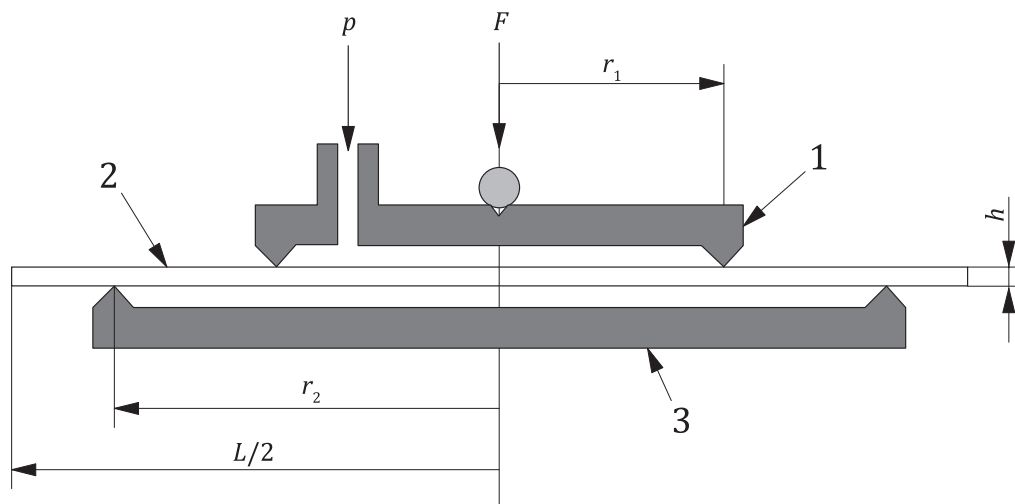

Key

- loading ring
- specimen
- supporting ring

Figure 1 — Basic diagram of test apparatus

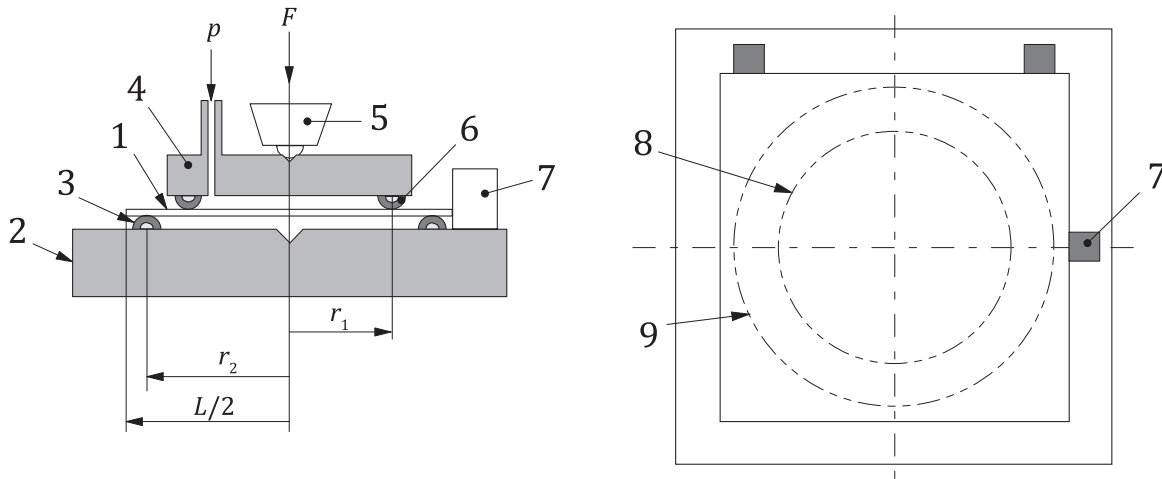

Key

- 1 specimen
 - 2 rigid base plate, preferably made of steel, with supporting ring (radius r_2)^a
 - 3 rubber profile, adapted to the supporting ring, 3 mm thick, with a hardness (40 ± 10) IRHD (in accordance with ISO 48)
 - 4 rigid loading ring (radius r_1), preferably made of steel^a
 - 5 force transmitting component, with a ball mechanism to ensure the force is centred in the loading ring
 - 6 rubber profile, adapted to the loading ring, 3 mm thick with a hardness (40 ± 10) IRHD (in accordance with ISO 48)^b
 - 7 adjustment jaws for centring the specimen
 - 8 contact circle of the loading ring
 - 9 contact circle of the supporting ring
- ^a The radius of curvature of the bearing surface of the ring is 5 mm.
- ^b In the case of specimens which are patterned on the loading ring side, a sponge rubber profile approximately 5 mm thick should also be used to ensure an adequate seal for the gas pressure.
- ^c The jaws are removed before the bending test is started, in order that the edge of the specimen is not clamped.

Figure 2 — Loading device

6.2 Loading device

6.2.1 Ring load

The ring load shall be applied using a loading device as shown in [Figure 2](#). The dimensions of the loading device are given in [Table 1](#).

Table 1 — Dimensions for the loading ring and supporting ring

Dimensions in millimetres

Loading ring r_1	Supporting ring r_2	Effective surface area mm^2
300 ± 1	400 ± 1	240 000

6.2.2 Surface pressure regulator

The loading device for the surface pressure is shown in [Figure 2](#).

The regulator shall be chosen with regard to accuracy and flow rate in such a way that the nominal function, $p(F)$, as shown in [Figure 3](#) or [Table 3](#), can be met (see [Annex A](#)).

6.3 Measuring instruments

The following measuring instruments are required:

- a measuring instrument enabling the width of the specimen to be measured to the nearest 1 mm;
- a measuring instrument allowing the thickness of the specimen to be measured to the nearest 0,01 mm.

7 Sample

7.1 Shape and dimensions of the specimens

Square specimens of the dimensions shown in [Table 2](#) shall be used.

The minimum thickness given for the specimens has been calculated in such a way that the effect of the self-weight of the specimen upon the stress distribution can be ignored.

Table 2 — Dimensions of specimens

Dimensions in millimetres

Specimen side length L	Minimum nominal specimen thickness	Average specimen radius (for evaluation) r_{3m}
$1\ 000 \pm 4$	3	600

The following tolerances for the specimens shall be observed.

In the case of specimens with flat surfaces:

- the evenness tolerance shall be 0,3 mm;
- the parallelism tolerance shall be 2 % of the specimen thickness.

In the case of specimens with one or two patterned surfaces:

- the fluctuations of the plate thickness (see [8.3](#)) shall be not more than 4 % and the local deviations from the average thickness (due to the depth of the pattern) shall be a maximum 30 % or 2 mm, whichever is the lower.

7.2 Sampling and preparation of specimens

7.2.1 Cutting and handling

The greatest care shall be taken that the test surface, which will be subsequently subjected to tensile stress, does not come into contact with tools, grinding agents, glass splinters, etc., and also is not damaged during storage.

NOTE 1 In order to preserve specific surface conditions, the test surface can be provided with a protective coating (glued down) during specimen preparation.

NOTE 2 The method of cutting specimens is not significant and no edge processing is necessary.

7.2.2 Conditioning

Protective coatings shall be removed 24 h before the test (see ISO 1288-1). The specimen shall be stored in the test environment (see [8.1](#) and [8.2](#)) for at least 4 h before testing.

7.2.3 Examination

Before the bending strength test, all specimens shall be examined over the test surface area for any faults which are not representative of the quality characteristics of the material tested.

7.2.4 Adhesive film

To hold together the fragments, an adhesive film shall be fixed to the side of the specimen facing the loading ring. This facilitates location of the fracture origin and measurement of the specimen thickness.

7.3 Number of specimens

The number of specimens to be tested shall be determined depending on the confidence limits required, especially with regard to estimating the extremes of the strength distribution (see ISO 1288-1 for a discussion of numbers of specimens).

8 Procedure

8.1 Temperature

The coaxial ring bending test shall be carried out at a temperature of (23 ± 5) °C. During the test, the temperature of the specimen shall be kept constant to 1 °C, in order to avoid the development of thermal stresses.

iTeh STANDARD PREVIEW
(standards.iteh.ai)

8.2 Humidity

The coaxial ring bending test shall be carried out at a relative humidity between 40 % and 70 %.

ISO 1288-2:2016

8.3 Thickness measurement

<https://standards.iteh.ai/catalog/standards/sist/6d940be8-36ad-4a68-ac5d-d37912f91a14/iso-1288-2-2016>

Since the nominal pressure function, $p(F)$, in accordance with [Figure 3](#) or [Table 3](#), is dependent upon the specimen thickness, h , this shall be determined before starting the test.

For this purpose, the thickness shall be measured at a minimum of eight points on the edge of the specimen. For specimens with one or two ornamental surfaces, both the plate thickness and the core thickness shall be measured. The average is taken from all these measured values.

The value obtained in this way for the specimen thickness or the equivalent specimen thickness, h , is used to determine the nominal pressure function, $p(F)$. By measuring the thickness on the edge of the specimen, undesirable damage to the surface caused by measuring tools does not affect the fracture behaviour.

8.4 Base plate

The base plate is centred by moving down the force transmitting component (without the loading ring and specimen) into the adjusting cone (see [Figure 2](#)). The base plate shall be fixed in this position. Glass splinters and other hard and sharp-edged particles shall be cleaned from the supporting ring. Damage to the supporting ring shall be eliminated.

8.5 Positioning of specimen and loading ring

The specimen is positioned with the surface to be tested downwards. The loading ring, from which glass splinters and other hard and sharp-edged particles have been removed, is placed on the upper side of the specimen and centred. The rubber connection attached to the loading ring shall be checked for its sealing effect and if necessary replaced. Damage to the loading ring shall be eliminated.

8.6 Load application

The piston force, F , and the gas pressure, p , shall be increased continuously until the specimen breaks. The inter-relationship, $p(F)$, to be maintained during the loading, shall be determined from the non-dimensional representation in [Figure 3](#) (curve p^*) or [Table 3](#). The following relationships exist between the non-dimensional parameters, p^* and F^* , and the values p and F .

$$p = p^* \frac{Eh^4}{r_{3m}^4 (1 - \mu^2)} \quad (1)$$

$$F = F^* \frac{Eh^4}{r_{3m}^2 (1 - \mu^2)} \quad (2)$$

The piston force, F , and the gas pressure, p , shall be monitored up to breakage of the specimen, to check whether the nominal function, $p(F)$, meets that shown in [Figure 3](#) or [Table 3](#).

NOTE Only if the nominal pressure function, $p(F)$, is followed, is a uniform radial tensile stress distribution developed on the convexly bent surface, in that area of the specimen defined by the loading ring. Keeping the gas pressure, p , in line with the piston force, F , may be carried out manually by means of a control valve, but it is recommended that the gas pressure, p , be controlled automatically as a function of the piston force, F . It is permissible to linearize the function $p^*(F^*)$ given in [Figure 3](#) for loads close to fracture. A suitable arrangement is described in [Annex A](#).

The maximum force, F_{\max} , and the associated gas pressure, p_{\max} , shall be measured.

From these two values, the stress at break, σ_{BB} or σ_{beqB} , in MPa, shall be determined in accordance with [Figure 3](#) or [Table 3](#) (see [9.2](#)).

8.7 Loading rate

The increase with time of the piston force and the associated gas pressure shall be chosen in such a way that the radial tensile stress in the centre of the specimen increases at a rate of $(2 \pm 0,4)$ MPa/s until the specimen breaks. Since there is no linear relationship between the stress and the piston force, the permissible loading rate shall be determined in accordance with [Figure 3](#) or [Table 3](#).

A preliminary test is recommended in order to determine the rate of loading.

NOTE Since the breakage stress is most dependent on the loading rate in the few seconds before fracture, it is permissible to set that loading rate required at loads close to fracture constant over the entire test.

8.8 Location of the origin

The location of the origin of the fracture (see Reference [\[5\]](#)) shall be determined from the fragments. The position of the origin of the fracture “inside or outside the contact circle of the loading ring” shall be determined for every specimen.

NOTE After fracture, further thickness measurements, for control purposes, can be made on fragments from the centre of the specimen bounded by the loading ring contact circle, preferably as close to the fracture origin as possible.

8.9 Assessment of residual stresses

If the specimens are considered to be free from inherent stresses, (that is, they are of annealed glass), this condition shall be examined photo-elastically, in the case of transparent glasses, on specimens or suitable fragments. Stress-free specimens placed between cross-polarized polarizing filters shall not show any significant brightness variations when viewed through the cross-section over an optical path length of 5 mm.