



SLOVENSKI STANDARD SIST ISO 5781:2021

01-julij-2021

Nadomešča:
SIST ISO 5781:2001

Fluidna tehnika - Hidravlika - Tlačno-reducirni ventili, sekvenčni ventili, razbremenilni ventili, dušilni ventili in protipovratni ventili - Priključne površine

Hydraulic fluid power -- Pressure-reducing valves, sequence valves, unloading valves, throttle valves and check valves -- Mounting surfaces

iTeh STANDARD PREVIEW (standards.iteh.ai)

Transmissions hydrauliques -- Réducteurs de pression, soupapes de séquence, soupapes de décharge, soupapes d'étranglement et clapets de non-retour -- Plan de pose

<https://standards.iteh.ai/catalog/standards/sist/b057b603-233d-4be7-a286-b1aac11704da/sist-iso-5781-2021>

Ta slovenski standard je istoveten z: ISO 5781:2016

ICS:

23.060.01	Ventili na splošno	Valves in general
23.100.50	Krmilni sestavni deli	Control components

SIST ISO 5781:2021

en

iTeh STANDARD PREVIEW
(standards.iteh.ai)

SIST ISO 5781:2021

<https://standards.iteh.ai/catalog/standards/sist/b057b603-233d-4be7-a286-b1aac11704da/sist-iso-5781-2021>

INTERNATIONAL
STANDARD

ISO
5781

Third edition
2016-08-01

Hydraulic fluid power — Pressure-reducing valves, sequence valves, unloading valves, throttle valves and check valves — Mounting surfaces

Transmissions hydrauliques — Réducteurs de pression, soupapes de séquence, soupapes de décharge, soupapes d'étranglement et clapets de non-retour — Plan de pose

iTeh STANDARD PREVIEW
(standards.iteh.ai)

[SIST ISO 5781:2021](https://standards.iteh.ai/catalog/standards/sist/b057b603-233d-4be7-a286-b1aac11704da/sist-iso-5781-2021)

<https://standards.iteh.ai/catalog/standards/sist/b057b603-233d-4be7-a286-b1aac11704da/sist-iso-5781-2021>



Reference number
ISO 5781:2016(E)

© ISO 2016

iTeh STANDARD PREVIEW (standards.iteh.ai)

[SIST ISO 5781:2021](https://standards.iteh.ai/catalog/standards/sist/b057b603-233d-4be7-a286-b1aac11704da/sist-iso-5781-2021)

<https://standards.iteh.ai/catalog/standards/sist/b057b603-233d-4be7-a286-b1aac11704da/sist-iso-5781-2021>



COPYRIGHT PROTECTED DOCUMENT

© ISO 2016, Published in Switzerland

All rights reserved. Unless otherwise specified, no part of this publication may be reproduced or utilized otherwise in any form or by any means, electronic or mechanical, including photocopying, or posting on the internet or an intranet, without prior written permission. Permission can be requested from either ISO at the address below or ISO's member body in the country of the requester.

ISO copyright office
Ch. de Blandonnet 8 • CP 401
CH-1214 Vernier, Geneva, Switzerland
Tel. +41 22 749 01 11
Fax +41 22 749 09 47
copyright@iso.org
www.iso.org

Contents		Page
Foreword		iv
Introduction		v
1	Scope	1
2	Normative references	1
3	Terms and definitions	1
4	Symbols	1
5	Tolerances	2
6	Dimensions	2
7	Port marking	2
8	Modular stack valves	3
9	Rated pressure	3
10	Identification statement (reference to this International Standard)	3
Bibliography		24

iTeh STANDARD PREVIEW
(standards.iteh.ai)

[SIST ISO 5781:2021](https://standards.iteh.ai/catalog/standards/sist/b057b603-233d-4be7-a286-b1aac11704da/sist-iso-5781-2021)

<https://standards.iteh.ai/catalog/standards/sist/b057b603-233d-4be7-a286-b1aac11704da/sist-iso-5781-2021>

ISO 5781:2016(E)

Foreword

ISO (the International Organization for Standardization) is a worldwide federation of national standards bodies (ISO member bodies). The work of preparing International Standards is normally carried out through ISO technical committees. Each member body interested in a subject for which a technical committee has been established has the right to be represented on that committee. International organizations, governmental and non-governmental, in liaison with ISO, also take part in the work. ISO collaborates closely with the International Electrotechnical Commission (IEC) on all matters of electrotechnical standardization.

The procedures used to develop this document and those intended for its further maintenance are described in the ISO/IEC Directives, Part 1. In particular the different approval criteria needed for the different types of ISO documents should be noted. This document was drafted in accordance with the editorial rules of the ISO/IEC Directives, Part 2 (see www.iso.org/directives).

Attention is drawn to the possibility that some of the elements of this document may be the subject of patent rights. ISO shall not be held responsible for identifying any or all such patent rights. Details of any patent rights identified during the development of the document will be in the Introduction and/or on the ISO list of patent declarations received (see www.iso.org/patents).

Any trade name used in this document is information given for the convenience of users and does not constitute an endorsement.

For an explanation on the meaning of ISO specific terms and expressions related to conformity assessment, as well as information about ISO's adherence to the WTO principles in the Technical Barriers to Trade (TBT), see the following URL: [Foreword — Supplementary information](#).

The committee responsible for this document is ISO/TC 131, *Fluid power systems*, Subcommittee SC 5, *Control products and components*.

This third edition cancels and replaces the second edition (ISO 5781:2000), which has been technically revised.

Introduction

In hydraulic fluid power systems, power is transmitted and controlled through a liquid under pressure circulating within an enclosed circuit. The most typical components found in such systems are hydraulic valves. They control flow direction, pressure or the flow rate of liquids in the enclosed circuit.

iTeh STANDARD PREVIEW (standards.iteh.ai)

[SIST ISO 5781:2021](https://standards.iteh.ai/catalog/standards/sist/b057b603-233d-4be7-a286-b1aac11704da/sist-iso-5781-2021)

<https://standards.iteh.ai/catalog/standards/sist/b057b603-233d-4be7-a286-b1aac11704da/sist-iso-5781-2021>

iTeh STANDARD PREVIEW
(standards.iteh.ai)

SIST ISO 5781:2021

<https://standards.iteh.ai/catalog/standards/sist/b057b603-233d-4be7-a286-b1aac11704da/sist-iso-5781-2021>

Hydraulic fluid power — Pressure-reducing valves, sequence valves, unloading valves, throttle valves and check valves — Mounting surfaces

1 Scope

This International Standard specifies the dimensions and other data relating to surfaces on which hydraulic pressure-reducing valves, sequence valves, unloading valves, throttle valves and check valves are mounted in order to ensure interchangeability.

It applies to mounting surfaces for hydraulic pressure-reducing valves, sequence valves, unloading valves, throttle valves and check valves, which represent current practice; they are generally applicable to industrial equipment.

2 Normative references

The following documents, in whole or in part, are normatively referenced in this document and are indispensable for its application. For dated references, only the edition cited applies. For undated references, the latest edition of the referenced document (including any amendments) applies.

ISO 1219-1, *Fluid power systems and components — Graphical symbols and circuit diagrams — Part 1: Graphical symbols for conventional use and data-processing applications*

ISO 3601-2:2008, *Fluid power systems — O-rings — Part 2: Housing dimensions for general applications*

ISO 4401, *Hydraulic fluid power — Four-port directional control valves — Mounting surfaces*

ISO 5598, *Fluid power systems and components — Vocabulary*

ISO 5783, *Hydraulic fluid power — Code for identification of valve mounting surfaces and cartridge valve cavities*

3 Terms and definitions

For the purposes of this document, the terms and definitions given in ISO 5598 and the graphical symbols given in ISO 1219-1 apply.

4 Symbols

4.1 For the purposes of this International Standard, the following symbols apply:

- a) A, B, P, T, X and Y identify ports;
- b) F₁, F₂, F₃, F₄, F₅ and F₆ identify threaded holes for fixing screws;
- c) G identifies the location of pin holes;
- d) D identifies the fixing screw diameter;
- e) r_{\max} identifies the mounting surface edge radius.

4.2 The graphic symbols used in [Tables 2, 3, 5, 6, 8, 9, 11, 12, 14](#) and [15](#) are in conformance with the graphical symbols in ISO 1219-1.

ISO 5781:2016(E)

4.3 The code system used in this International Standard is defined in ISO 5783.

5 Tolerances

5.1 The following values shall be applied to the mounting surface, i.e. the area within the dashed double-dotted lines:

- surface roughness: ISO 3601-2:2008, 5.1.4 and 5.2.3;
- surface flatness: 0,01 mm over a distance of 100 mm (see ISO 3601-2:2008, 5.1.4);
- tolerance on diameters of locating pin holes: H12.

5.2 With respect to the point of origin, the following tolerances shall be complied with along the *x* and *y* axes:

- pin holes: $\pm 0,1$ mm;
- screw holes: $\pm 0,1$ mm;
- main ports: $\pm 0,2$ mm.

For the other dimensions, see the figures.

6 Dimensions

iTeh STANDARD PREVIEW
(standards.iteh.ai)

6.1 Mounting surface dimensions for hydraulic pressure-reducing valves, sequence valves, unloading valves, throttle valves and check valves shall be selected from the figures and tables specified in 6.2 to 6.6.

6.2 Mounting surface dimensions for pressure-reducing valves, sequence valves, unloading valves, throttle valves and check valves with main ports of 4,5 mm maximum diameter (code: 5781-02-01-0-16) are given in [Figure 1](#) and [Table 1](#).

6.3 Mounting surface dimensions for pressure-reducing valves, sequence valves, unloading valves, throttle valves and check valves with main ports of 7,5 mm maximum diameter (code: 5781-03-04-0-16) are given in [Figure 2](#) and [Table 4](#).

6.4 Mounting surface dimensions for pressure-reducing valves, sequence valves, unloading valves, throttle valves and check valves with main ports of 14,7 mm maximum diameter (code: 5781-06-07-0-16) are given in [Figure 3](#) and [Table 7](#).

6.5 Mounting surface dimensions for pressure-reducing valves, sequence valves, unloading valves, throttle valves and check valves with main ports of 23,4 mm maximum diameter (code: 5781-08-10-0-16) are given in [Figure 4](#) and [Table 10](#).

6.6 Mounting surface dimensions for pressure-reducing valves, sequence valves, unloading valves, throttle valves and check valves with main ports of 32 mm maximum diameter (code: 5781-10-13-0-16) are given in [Figure 5](#) and [Table 13](#).

7 Port marking

7.1 The port symbols to be used for pressure-reducing valves, sequence valves, unloading valves, throttle valves and check valves shall be selected from the figures specified in [7.2](#) to [7.11](#).

7.2 The symbols for directly-operated pressure-reducing valves, sequence valves, unloading valves, throttle valves and check valves with main ports of 4,5 mm maximum diameter (code: 5781-02-01-0-16) are given in [Table 2](#).

7.3 The symbols for pilot-operated pressure-reducing valves, sequence valves and unloading valves with main ports of 4,5 mm maximum diameter (code: 5781-02-01-0-16) are given in [Table 3](#).

7.4 The symbols for directly-operated pressure-reducing valves, sequence valves, unloading valves, throttle valves and check valves with main ports of 7,5 mm maximum diameter (code: 5781-03-04-0-16) are given in [Table 5](#).

7.5 The symbols for pilot-operated pressure-reducing valves, sequence valves and unloading valves with main ports of 7,5 mm maximum diameter (code: 5781-03-04-0-16) are given in [Table 6](#).

7.6 The symbols for directly-operated pressure-reducing valves, sequence valves, unloading valves, throttle valves and check valves with main ports of 14,7 mm maximum diameter (code: 5781-06-07-0-16) are given in [Table 8](#).

7.7 The symbols for pilot-operated pressure-reducing valves, sequence valves and unloading valves with main ports of 14,7 mm maximum diameter (code: 5781-06-07-0-16) are given in [Table 9](#).

7.8 The symbols for directly-operated pressure-reducing valves, sequence valves, unloading valves, throttle valves and check valves with main ports of 23,4 mm maximum diameter (code: 5781-08-10-0-16) are given in [Table 11](#).

7.9 The symbols for pilot-operated pressure-reducing valves, sequence valves and unloading valves with main ports of 23,4 mm maximum diameter (code: 5781-08-10-0-16) are given in [Table 12](#).

7.10 The symbols for directly-operated pressure-reducing valves, sequence valves, unloading valves, throttle valves and check valves with main ports of 32 mm maximum diameter (code: 5781-10-13-0-16) are given in [Table 14](#).

7.11 The symbols for pilot-operated pressure-reducing valves, sequence valves and unloading valves with main ports of 32 mm maximum diameter (code: 5781-10-13-0-16) are given in [Table 15](#).

7.12 The direction A to B should not be used in new designs. This variant will be removed when this International Standard is next revised.

8 Modular stack valves

For modular stack valves, the mounting surfaces and port markings defined in ISO 4401 shall be used.

9 Rated pressure

For indication of the maximum limit of the working pressure, see Note 1 in the [Figures 1, 2, 3, 4](#) and [5](#).

10 Identification statement (reference to this International Standard)

Use the following statement in test reports, catalogues and sales literature when electing to comply with this International Standard:

“Mounting surface dimensions conform to ISO 5781:2016, *Hydraulic fluid power — Pressure-reducing valves, sequence valves, unloading valves, throttle valves and check valves — Mounting surfaces.*”

ISO 5781:2016(E)

Dimensions in millimetres

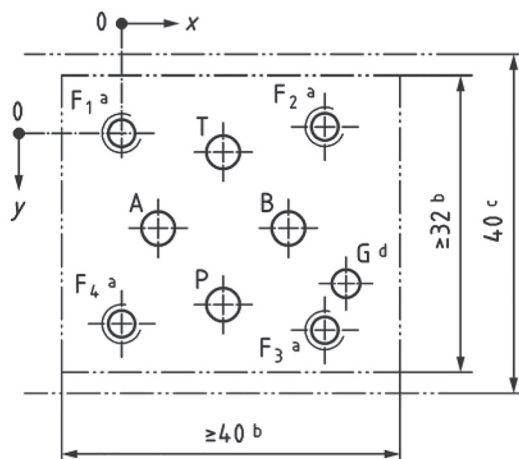

Key

- a The minimum thread depth is 1,5 times the screw diameter, D . The full thread depth recommended is $2D + 6$ mm, to facilitate interchangeability of valves and reduce the number of fixing screw lengths. The recommended engagement of fixing screw thread for ferrous mountings is $1,25D$.
- b The dimensions specifying the area within the dashed double-dotted lines are the minimum dimensions for the mounting surface. The corners of the rectangle may be radiused to a maximum radius, r_{\max} , equal to the thread diameter of the fixing screws.
- c This dimension gives the minimum space required for a valve with this mounting surface. The dimension is also the minimum distance from centreline to centreline of two identical mounting surfaces placed on a manifold block.
- d Blind hole in the mounting surface to accommodate the locating pin on the valves; the minimum depth is 4 mm.

NOTE 1 The supplier shall stipulate the maximum working pressure for subplates and manifold blocks.

NOTE 2 See [Tables 2](https://standards.iteh.ai/catalog/standards/sist/b057b603-233d-4be7-a286-704da/sist-iso-5781-2021) and [3](https://standards.iteh.ai/catalog/standards/sist/b057b603-233d-4be7-a286-704da/sist-iso-5781-2021) for graphical symbols.

Figure 1 — Mounting surface for pressure-reducing valves, sequence valves, unloading valves, throttle valves and check valves with main ports of 4,5 mm maximum diameter (code: 5781-02-01-0-16)

Table 1 — Mounting surface for pressure-reducing valves, sequence valves, unloading valves, throttle valves and check valves with main ports of 4,5 mm maximum diameter (code: 5781-02-01-0-16)

Axis	P	A	T	B	F1	F2	F3	F4	G
	∅ 4,5 max.	∅ 4,5 max.	∅ 4,5 max.	∅ 4,5 max.	M5	M5	M5	M5	∅ 3,4
x	12	4,3	12	19,7	0	24	24	0	26,5
y	20,25	11,25	2,25	11,25	0	-0,75	23,25	22,5	17,75