



SLOVENSKI STANDARD SIST EN 840-5:2020

01-junij-2020

Nadomešča:
SIST EN 840-5:2014

Premični zabojniki za odpadke in za recikliranje - 5. del: Zahtevane lastnosti in preskusne metode

Mobile waste and recycling containers - Part 5: Performance requirements and test methods

Fahrbare Abfall- und Wertstoffbehälter - Teil 5: Anforderungen an die Ausführung und Prüfverfahren

(standards.iteh.ai)

Conteneurs roulants à déchets et de recyclage - Partie 5 : Exigences de performance et méthodes d'essais

<https://standards.iteh.ai/catalog/standards/sist/2749e6ce-dfb8-4912-8385-8566cbebd111/sist-en-840-5-2020>

Ta slovenski standard je istoveten z: **EN 840-5:2020**

ICS:

13.030.40	Naprave in oprema za odstranjevanje in obdelavo odpadkov	Installations and equipment for waste disposal and treatment
-----------	----------------------------------------------------------	--------------------------------------------------------------

SIST EN 840-5:2020

en,fr,de

iTeh STANDARD PREVIEW
(standards.iteh.ai)

[SIST EN 840-5:2020](#)

<https://standards.iteh.ai/catalog/standards/sist/2749e6ce-dfb8-4912-8385-8566cbebd111/sist-en-840-5-2020>

EUROPEAN STANDARD
NORME EUROPÉENNE
EUROPÄISCHE NORM

EN 840-5

April 2020

ICS 13.030.40

Supersedes EN 840-5:2012

English Version

**Mobile waste and recycling containers - Part 5:
Performance requirements and test methods**

Conteneurs roulants à déchets et de recyclage - Partie 5
: Exigences de performance et méthodes d'essais

Fahrbare Abfall- und Wertstoffbehälter - Teil 5:
Anforderungen an die Ausführung und Prüfverfahren

This European Standard was approved by CEN on 7 October 2019.

CEN members are bound to comply with the CEN/CENELEC Internal Regulations which stipulate the conditions for giving this European Standard the status of a national standard without any alteration. Up-to-date lists and bibliographical references concerning such national standards may be obtained on application to the CEN-CENELEC Management Centre or to any CEN member.

This European Standard exists in three official versions (English, French, German). A version in any other language made by translation under the responsibility of a CEN member into its own language and notified to the CEN-CENELEC Management Centre has the same status as the official versions.

CEN members are the national standards bodies of Austria, Belgium, Bulgaria, Croatia, Cyprus, Czech Republic, Denmark, Estonia, Finland, France, Germany, Greece, Hungary, Iceland, Ireland, Italy, Latvia, Lithuania, Luxembourg, Malta, Netherlands, Norway, Poland, Portugal, Republic of North Macedonia, Romania, Serbia, Slovakia, Slovenia, Spain, Sweden, Switzerland, Turkey and United Kingdom.

<https://standards.iteh.ai/catalog/standards/sist/2749e6ce-dfb8-4912-8385-8566cbebd111/sist-en-840-5-2020>



EUROPEAN COMMITTEE FOR STANDARDIZATION
COMITÉ EUROPÉEN DE NORMALISATION
EUROPÄISCHES KOMITEE FÜR NORMUNG

CEN-CENELEC Management Centre: Rue de la Science 23, B-1040 Brussels

Contents

	Page
European foreword.....	3
1 Scope	4
2 Normative references	4
3 Terms and definitions	4
4 Tests	5
4.1 General	5
4.2 Control before the tests	5
4.3 Control after the tests	6
4.4 Conditions of the test	6
4.5 Test load	6
4.6 Other test conditions	6
4.7 Tests on the containers	7
4.8 Stability test	12
4.9 Pulling and rolling tests	12
4.10 Lifting-tilting tests	15
4.11 Miscellaneous tests	16
5 Test report	21
Annex A (informative) Slope and stop for “kerb travel” test	22
Annex B (informative) Apparatus for kerb fall test	23
Annex C (informative) Apparatus for lateral impact test on inclined plane	25
Annex D (informative) Wheel Test	26
Annex E (informative) Weathering tests	27
Bibliography	28

European foreword

This document (EN 840-5:2020) has been prepared by Technical Committee CEN/TC 183 "Waste management", the secretariat of which is held by DIN.

This European Standard shall be given the status of a national standard, either by publication of an identical text or by endorsement, at the latest by October 2020, and conflicting national standards shall be withdrawn at the latest by October 2020.

Attention is drawn to the possibility that some of the elements of this document may be the subject of patent rights. CEN shall not be held responsible for identifying any or all such patent rights.

This document supersedes EN 840-5:2012.

The main changes compared to the previous edition are listed below:

- a) 4.11.2 "Handle test" has been updated;
- b) Table 4 "Sequence of tests" has been corrected;
- c) the document has been editorially revised and adapted to the new design rules.

According to the CEN-CENELEC Internal Regulations, the national standards organisations of the following countries are bound to implement this European Standard: Austria, Belgium, Bulgaria, Croatia, Cyprus, Czech Republic, Denmark, Estonia, Finland, France, Germany, Greece, Hungary, Iceland, Ireland, Italy, Latvia, Lithuania, Luxembourg, Malta, Netherlands, Norway, Poland, Portugal, Republic of North Macedonia, Romania, Serbia, Slovakia, Slovenia, Spain, Sweden, Switzerland, Turkey and the United Kingdom.

EN 840-5:2020 (E)**1 Scope**

This document gives the test methods for mobile waste and recycling containers according to EN 840-1 to EN 840-4. It also gives the levels to be reached during the tests or after they have been done.

This document is applicable to mobile waste and recycling containers with capacities up to 1 700 l.

2 Normative references

The following documents are referred to in the text in such a way that some or all of their content constitutes requirements of this document. For dated references, only the edition cited applies. For undated references, the latest edition of the referenced document (including any amendments) applies.

EN 840-1, *Mobile waste and recycling containers — Part 1: Containers with 2 wheels with a capacity up to 400 l for comb lifting devices — Dimensions and design*

EN 840-2, *Mobile waste and recycling containers — Part 2: Containers with 4 wheels with a capacity up to 1 300 l with flat lid(s), for trunnion and/or comb lifting devices — Dimensions and design*

EN 840-3, *Mobile waste and recycling containers — Part 3: Containers with 4 wheels with a capacity up to 1 300 l with dome lid(s), for trunnion and/or comb lifting devices — Dimensions and design*

EN 840-4, *Mobile waste and recycling containers — Part 4: Containers with 4 wheels with a capacity up to 1 700 l with flat lid(s), for wide trunnion or BG- and/or wide comb lifting device — Dimensions and design*

EN 10142, *Continuously hot-dip zinc coated low carbon steels strip and sheet for cold forming — Technical delivery conditions*

EN ISO 1461, *Hot dip galvanized coatings on fabricated iron and steel articles - Specifications and test methods (ISO 1461)*

EN ISO 2081, *Metallic and other inorganic coatings - Electroplated coatings of zinc with supplementary treatments on iron or steel (ISO 2081)*

3 Terms and definitions

For the purposes of this document, the terms and definitions according to EN 840-1, EN 840-2, EN 840-3 and EN 840-4 apply.

ISO and IEC maintain terminological databases for use in standardization at the following addresses:

- IEC Electropedia: available at <http://www.electropedia.org/>
- ISO Online browsing platform: available at <https://www.iso.org/obp>

NOTE Terms for components of mobile waste and recycling containers and lifting devices in three languages are given in Annex A of EN 840-1:2020.

4 Tests

4.1 General

Before and after the tests a visual inspection of the container shall be done for the purpose of:

- a) checking that the container is not damaged and has no visual defect;
- b) checking that the manufacturing characteristics of the container to be tested are those specified in the standards applying to the container according to EN 840-1 to EN 840-4;
- c) comparing the condition of the container before and after the sequence of the tests.

After completing the tests some deformation of the container is permissible, however, it shall remain entirely functional.

4.2 Control before the tests

4.2.1 Visual aspects

No obvious damage, cracks, bubbles, large flashes or sharp edges shall be present. No surface defects (unsmooth areas; trails in colour) perceivable from a distance of 1 m by the naked eye shall be visible.

4.2.2 Compatibility with EN 840-1 to EN 840-4

4.2.2.1 Components

Body, lid, wheels and other fittings shall conform to the relevant container standard.

4.2.2.2 Sizes and dimensions

Functional and safety dimensions for the container and its components shall be checked according to the figures and the relevant tables of EN 840-1 to EN 840-4.

4.2.2.3 Volumes

The volumes of container shall be measured:

- a) for the body, by tank method;
- b) for the lid, by tank method;
- c) volume results in a) and b) minus any duplicated volumes.

The volumes shall be within the tolerances according to EN 840-1 to EN 840-4.

For containers according to EN 840-3 volume measurement by means of calculation is allowed.

4.2.2.4 Tank method

The test equipment shall consist of a tank with sufficient capacity to receive the container to be tested.

The test procedure is as follows:

- place the empty container in a tank, the container shall not be inclined;
- simultaneously fill the tank and the container with water at a temperature of $(15 \pm 5) ^\circ\text{C}$;
- measure the quantity of water inside the container.

EN 840-5:2020 (E)

Accuracy of measurement shall be $\pm 1\%$ of the measured capacity of the container.

4.2.3 Deflection for comb lifting system

The frontal receiver shall have a horizontal deflection of no more than:

- a) 1,5 % of the length of the frontal receiver for plastic;
- b) 0,6 % of the length for steel.

For other systems the values are to be defined when the systems are standardized.

4.2.4 Masses

The tolerances on the container mass claimed are as follows: for plastic containers $\pm 5\%$ and for metal containers $\pm 10\%$.

4.2.5 Colour

The colour shall be defined and agreed between customer and supplier. For colour measurement, differences and tolerances refer to existing International Standards.

4.2.6 Marking

Marking of the container shall correspond to EN 840-1 to EN 840-4.

4.3 Control after the tests

Notwithstanding variations in deflection and sizes, it shall be possible to lift and tilt the container loaded according to 4.5 with nominal load safely on the designated lifting equipment and to move the container on its wheels.

4.4 Conditions of the test

iTech STANDARD PREVIEW
<https://standards.itech.ai/catalog/standards/sist/2749e6ce-dfb8-4912-8385-8566cbebd111/sist-en-840-5-2020>

The tests shall be carried out at the following temperatures:

- $T_1 = (23 \pm 5) ^\circ\text{C}$
- $T_2 = (-18_{-2}^0) ^\circ\text{C}$.

The minimum duration of conditioning before testing at a test temperature T_2 shall be 12 h. If the test shall be carried out outside the room conditioned at T_2 it shall be carried out within 5 min after taking the test pieces from the conditioned room. If the duration of the tests is more than 5 min, then the container shall be kept in the conditioned room for at least 15 min before a new 5 min period of testing.

For special purposes a temperature lower than -18°C or higher than 23°C can be agreed; in this case it shall be indicated in the test report.

4.5 Test load

For the test the containers are to be filled with ballast bags of HDPE granules of 4 kg max., with granules having a density of $0,5\text{ kg/dm}^3$.

The test load shall be $0,4\text{ kg/dm}^3$ multiplied by nominal volume, but not more than 440 kg.

4.6 Other test conditions

Any other test conditions shall be defined within the tests involved.

4.7 Tests on the containers

4.7.1 General

All tests shall be carried out on new containers.

4.7.2 Impact tests by ball drop

The ball drop test is not compulsory for steel containers.

The ability of sensitive points of the container to resist impacts at low temperature shall be tested under conditions in 4.4.

The 2-wheeled containers shall be placed on a concrete or steel surface in the normal position.

There shall be a steel frame between the concrete surface or the steel surface and the container so that the complete area of the bottom of the container can be deflected during the test.

The 4-wheeled containers shall stand on their wheels.

Ball drop tests shall be carried out using a 5 kg steel cylinder, diameter 65 mm, with hemispheric end radius of 32,5 mm. The steel cylinder is guided in a vertical pipe with a slot or with holes in order to allow the air to escape during the drop.

The device shall be according to Figure 1.

iTeh STANDARD PREVIEW (standards.iteh.ai)

[SIST EN 840-5:2020](https://standards.iteh.ai/catalog/standards/sist/2749e6ce-dfb8-4912-8385-8566cbebd111/sist-en-840-5-2020)

<https://standards.iteh.ai/catalog/standards/sist/2749e6ce-dfb8-4912-8385-8566cbebd111/sist-en-840-5-2020>

Dimensions in millimetres

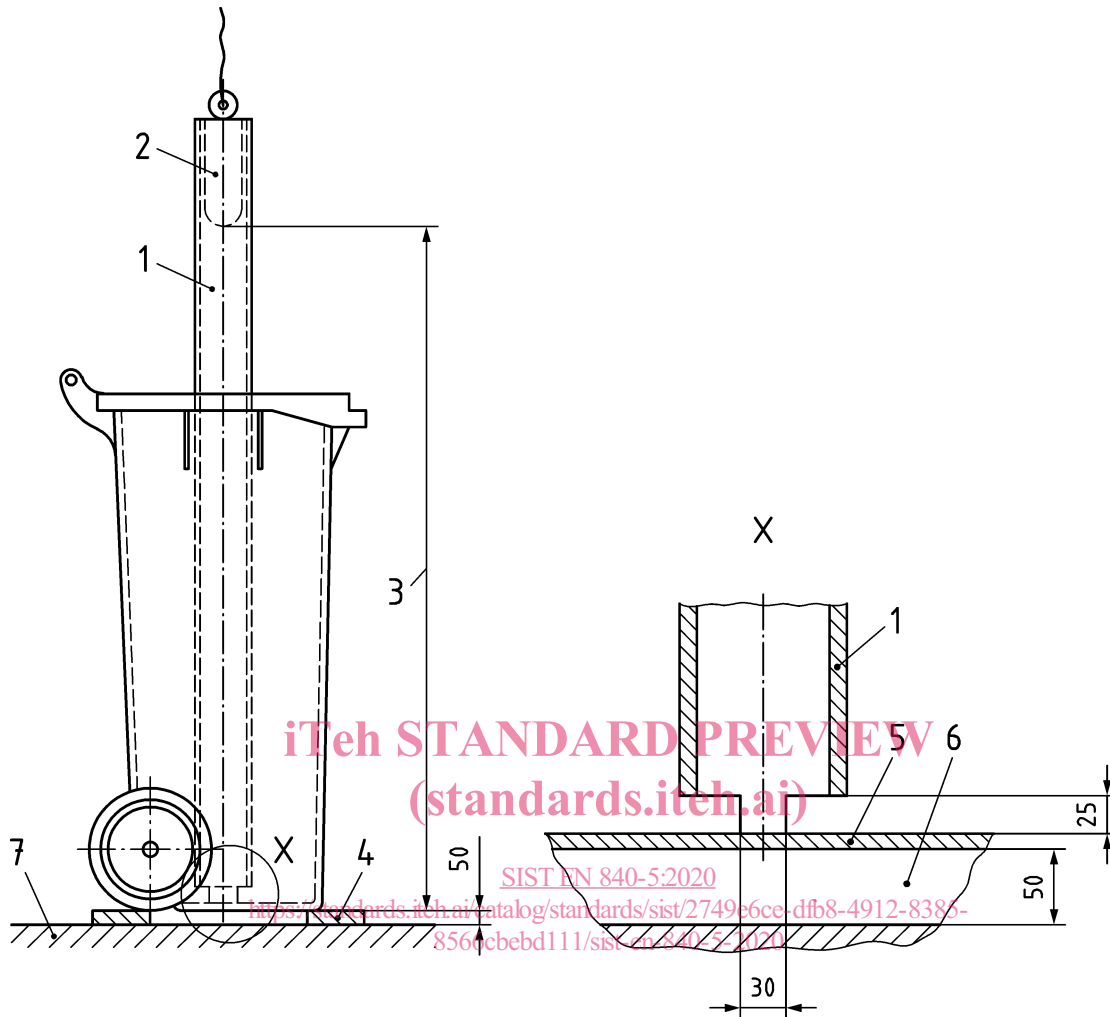
**Key**

- | | | | |
|---|-----------------------------------------------------------------|---|---------------------------|
| 1 | vertical (plastic) pipe (inside diameter: 70 mm) | 5 | container bottom |
| 2 | steel cylinder (diameter: 65 mm; 1 hemispheric end; mass: 5 kg) | 6 | free room |
| 3 | height fall (0,80 m) | 7 | concrete or steel surface |
| 4 | steel frame (see 4.7.2) | | |

Figure 1 — Device for ball drop test

The following areas of containers shall be tested by impact tests:

- a) on the body bottom (see Figure 2d) there shall be 3 successive impacts for each impact point defined below:

- 1) the injection point(s),
- 2) A and D or C and B.

after the test the container shall be waterproof in the tested points;

- b) there shall be 2 successive impacts for each impact point defined below (see Figures 2a), 2b), 2c))

- 1) the centre of the lid (E),
- 2) one corner of the lid (cylinder to be tangent to the lid) (F),
- 3) the corner diametrically opposite (cylinder to be tangent to the lid) (G),
- 4) each hinge (H),
- 5) the centre of the front face of the top rim (J),
- 6) the centre of a lateral face of the top rim (I),
- 7) the back corner opposite the lateral face previously tested of the top rim (K),
- 8) centre of any handle (L, see Figure 2c) key 2).

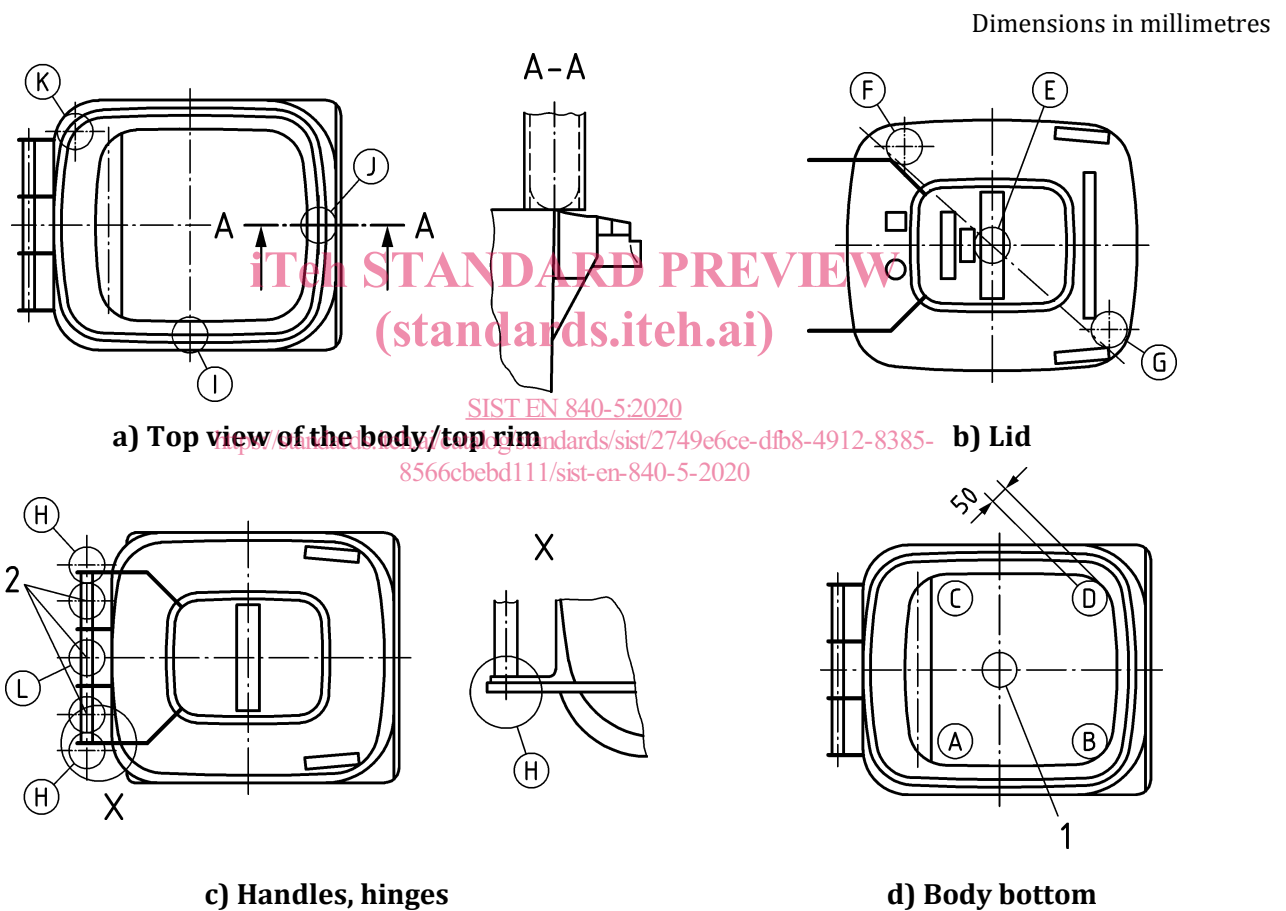

Key

- 1 injection point (if one injection point only, impact on it and on A - D or B - C)
- 2 middle of handle

Figure 2 — Impact points for ball drop test

Outside of the conditioning room (see 4.4), the test shall not last more than 5 min. After this time the container shall be reconditioned for at least 15 min.

After the test the following procedure shall be applied, if there is any doubt about the result:

EN 840-5:2020 (E)

- fill the body with a water volume equal to 10 % of the maximum capacity of the body;
- wait for 10 min.

After 10 min, if the container leaks, it is declared to be non-conforming.

4.7.3 Impacts on an inclined plane

Only 4-wheeled containers shall be tested with impact on each wall of the body and on each corner to check the resistance to straining and breaking of sensitive areas, including protruding areas and fittings. The test conditions shall be:

- test temperature T_1 = room temperature;
- test load according to 4.5;
- inclination of 10° (ten degrees) to the horizontal;
- impact against a wall perpendicular to the moving direction;
- a total of 16 impacts according to the sequence in Table 1.

During the procedure the lid shall be closed. The loaded container shall be placed on a trolley with an inclination of 10° (ten degrees) (relative to the horizontal). Precautions shall be taken to avoid accidental tipping of the container during the test (see Figure C.1).

Other apparatus than shown in Figure C.1 may be used if it allows the same impact and velocity conditions.

The impact velocity shall be $(1,85 \pm 0,05)$ m/s when a face is tested and $(1,3 \pm 0,05)$ m/s when a corner is tested.

The vertical faces of the container will be numbered from 1 to 4 and the face marked 1 being the large face fitted for the (comb) lifting system. Corners are marked 1.2, 2.3, 3.4 and 4.1.

Table 1 — Sequence of the lateral impacts

Impact n°	Face or corner tested	No of impacts
1 to 2	Face 1	2
3 to 4	Corner 1.2	2
5 to 6	Face 2	2
7 to 8	Corner 2.3	2
9 to 10	Face 3	2
11 to 12	Corner 3.4	2
13 to 14	Face 4	2
15 to 16	Corner 4.1	2

After completing the test some deformation of the container is permissible, however, it shall remain entirely functional.