



SLOVENSKI STANDARD
SIST ISO 1660:1995

01-junij-1995

HM b] bYf]gVY!`? ch]fUb^Y]b`hc`Yf]fUb^Y_f]j i `^

Technical drawings -- Dimensioning and tolerancing of profiles

Dessins techniques -- Cotation et tolérancement des profils

Ta slovenski standard je istoveten z: **ISO 1660:1987**

[SIST ISO 1660:1995](https://standards.iteh.ai/catalog/standards/sist/9289f24b-18d2-497f-9845-174623ac93c/sist-iso-1660-1995)

<https://standards.iteh.ai/catalog/standards/sist/9289f24b-18d2-497f-9845-174623ac93c/sist-iso-1660-1995>

ICS:

01.100.20	Konstrukcijske risbe	Mechanical engineering drawings
-----------	----------------------	---------------------------------

SIST ISO 1660:1995

en

iTeh STANDARD PREVIEW
(standards.iteh.ai)

[SIST ISO 1660:1995](#)

<https://standards.iteh.ai/catalog/standards/sist/9289f24b-18d2-497f-9845-17462f3ac93c/sist-iso-1660-1995>

INTERNATIONAL STANDARD

ISO
1660

Second edition
1987-11-01



INTERNATIONAL ORGANIZATION FOR STANDARDIZATION
ORGANISATION INTERNATIONALE DE NORMALISATION
МЕЖДУНАРОДНАЯ ОРГАНИЗАЦИЯ ПО СТАНДАРТИЗАЦИИ

Technical drawings — Dimensioning and tolerancing of profiles

Dessins techniques — Cotation et tolérancement des profils

ITeCh STANDARD PREVIEW
(standards.iteh.ai)

[SIST ISO 1660:1995](#)

<https://standards.iteh.ai/catalog/standards/sist/9289f24b-18d2-497f-9845-17462f3ac93c/sist-iso-1660-1995>

Foreword

ISO (the International Organization for Standardization) is a worldwide federation of national standards bodies (ISO member bodies). The work of preparing International Standards is normally carried out through ISO technical committees. Each member body interested in a subject for which a technical committee has been established has the right to be represented on that committee. International organizations, governmental and non-governmental, in liaison with ISO, also take part in the work.

Draft International Standards adopted by the technical committees are circulated to the member bodies for approval before their acceptance as International Standards by the ISO Council. They are approved in accordance with ISO procedures requiring at least 75 % approval by the member bodies voting.

International Standard ISO 1660 was prepared by Technical Committee ISO/TC 10, *Technical drawings*.

This second edition cancels and replaces the first edition (ISO 1660 : 1982), of which it constitutes a technical revision.

Users should note that all International Standards undergo revision from time to time and that any reference made herein to any other International Standard implies its latest edition, unless otherwise stated.

ITeH STANDARD PREVIEW
(standards.iteh.ai)

[SIST ISO 1660:1995](https://standards.iteh.ai/catalog/standards/sist/9289f24b-18d2-497f-9845-17462f047319/iso-1660-1995)

<https://standards.iteh.ai/catalog/standards/sist/9289f24b-18d2-497f-9845-17462f047319/iso-1660-1995>

[17462f047319/iso-1660-1995](https://standards.iteh.ai/catalog/standards/sist/9289f24b-18d2-497f-9845-17462f047319/iso-1660-1995)

Technical drawings — Dimensioning and tolerancing of profiles

iTeh STANDARD PREVIEW (standards.iteh.ai)

1 Scope and field of application

This International Standard describes the dimensioning and the geometrical tolerancing of profiled outlines and of profiled surfaces. The methods described are related to the sub-clauses in ISO 1101 dealing with the "profile tolerance of any line" and "profile tolerance of any surface".

2 Reference

ISO 1101, *Technical drawings — Geometrical tolerancing — Tolerancing of form, orientation, location and run-out — Generalities, definitions, symbols, indications on drawings.*

3 Dimensioning

Profiles may be dimensioned by either of the methods described in 3.1 and 3.2.

3.1 The successive radii of curvature and sufficient dimensions shall be given to locate the corresponding elements of the curve (see figure 1).

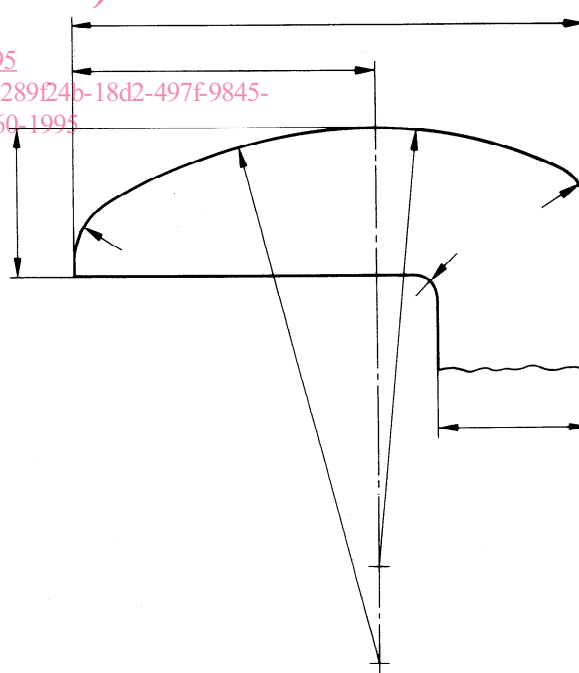

Figure 1

ISO 1660 : 1987 (E)

3.2 Linear or polar coordinates of a series of points through which the profile passes shall be given (see figure 2).

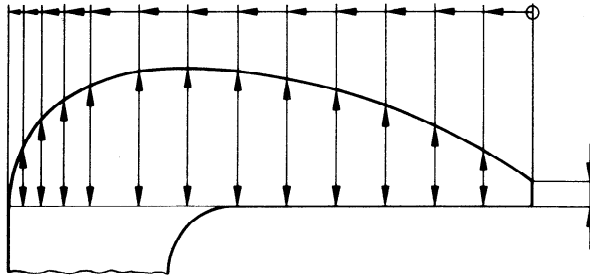
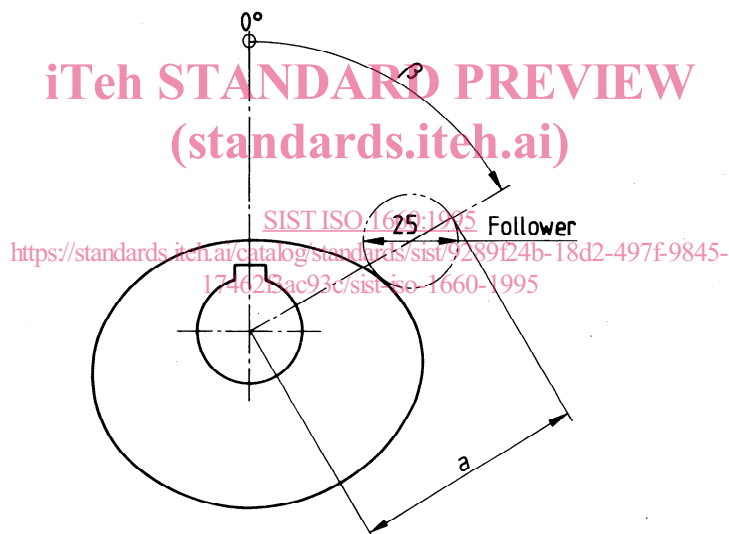

Figure 2

3.3 With either of the methods described in 3.1 or 3.2 it may be necessary to specify dimensions in association with a follower; the dimension, a , shall then be indicated on the drawing (see figure 3).



β	0°	20°	40°	60°	80°	100°	120 to 210°	230°	260°	280°	300°	320°	340°
a	50	52,5	57	63,5	70	74,5	76	75	70	65	59,5	55	52

Figure 3

4 Indication of tolerances

Profile dimensions may be toleranced by methods described in 4.1 and 4.2; the actual profile shall be contained within the specified tolerance zone.

4.1 Geometrical tolerancing of a line

The tolerance zone is defined with respect to the "true" profile which is itself defined by theoretically exact (basic) dimensions. The tolerance zone shall be equally disposed on either side of the true profile.

The width of the tolerance zone is uniform when measured normal to the true profile at any point (see figures 4 and 5).

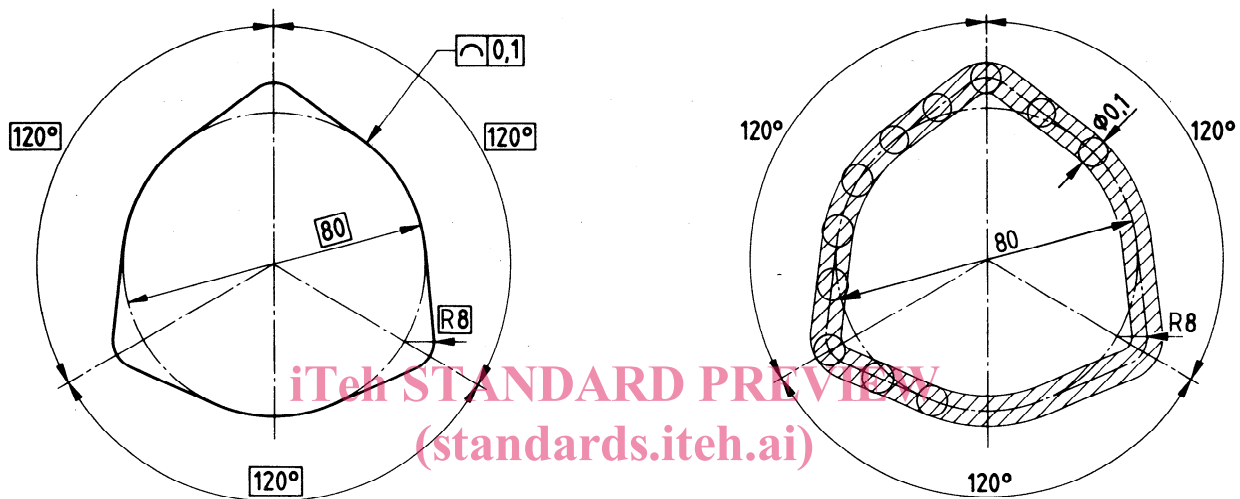

SIST ISO 1660:1995
<https://standards.iteh.ai/catalog/standards/sist/9289f24b-18d2-4976-9845-17462Bac93c/sist-iso-1660-1995>
 a) Indication on the drawing b) Interpretation

Figure 4

The tolerance zone is related to datum features.

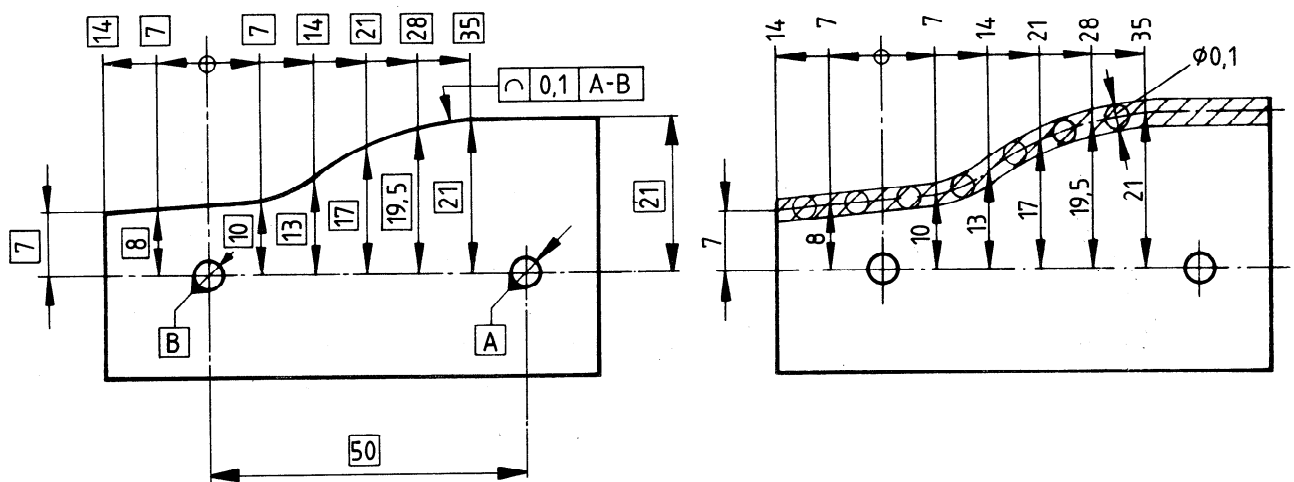

a) Indication on the drawing

b) Interpretation

Figure 5

ISO 1660 : 1987 (E)

4.2 Geometrical tolerancing of a profiled surface

The tolerance zone of a surface to be given a profile tolerance is defined with respect to the true profile which is itself defined by theoretically exact dimensions. This zone shall be equally disposed on either side of the true profile of the surface.

The width of the tolerance zone is uniform when measured normal to the true profile of the surface at any point (see figure 6).

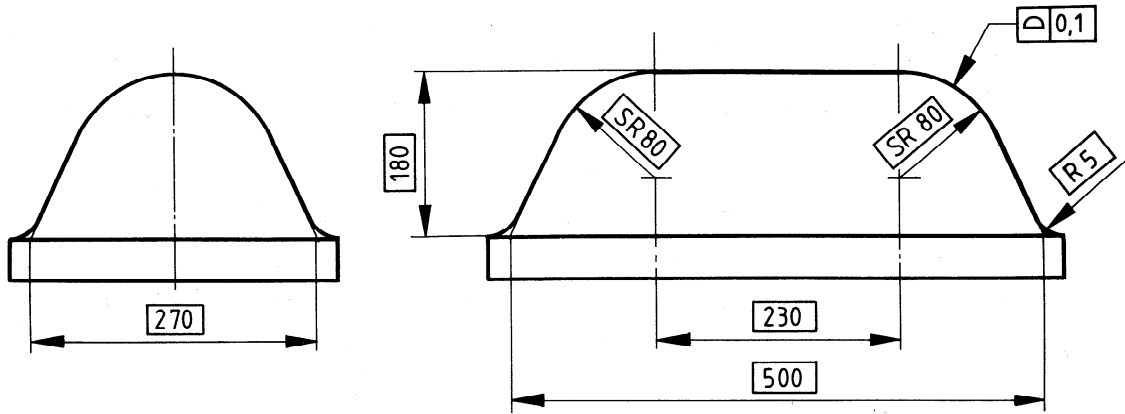

iTeh STANDARD PREVIEW
(standards.iteh.ai)

SIST ISO 1660:1995
<https://standards.iteh.ai/catalog/standards/sist/9289f24b-18d2-497f-9845-174623ac93c/sist-iso-1660-1995>

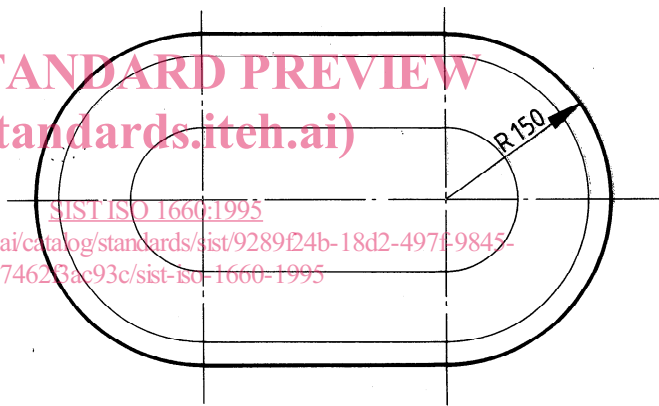

a) Indication on the drawing

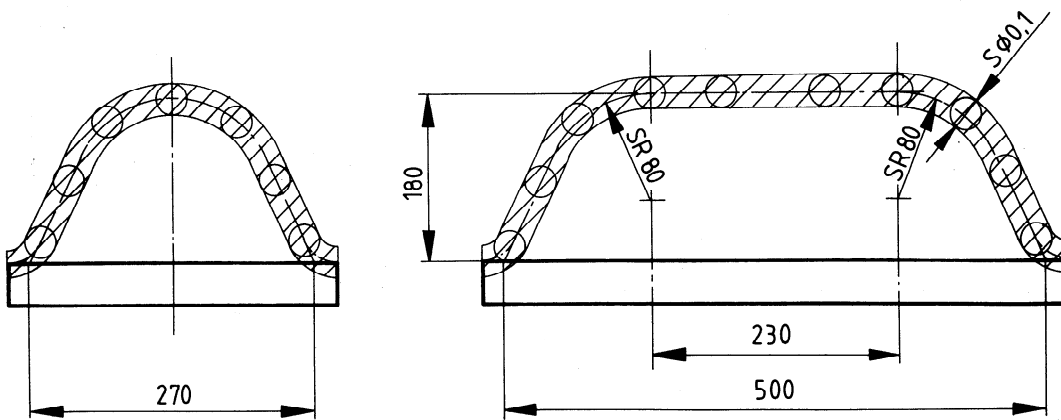

b) Interpretation

Figure 6