



Designation: ~~D4394-04~~ Designation: D 4394 – 08

Standard Test Method for Determining the In Situ Modulus of Deformation of Rock Mass Using the Rigid Plate Loading Method¹

This standard is issued under the fixed designation D 4394; the number immediately following the designation indicates the year of original adoption or, in the case of revision, the year of last revision. A number in parentheses indicates the year of last reapproval. A superscript epsilon (ϵ) indicates an editorial change since the last revision or reapproval.

1. Scope*

1.1 This test method covers the preparation, equipment, test procedure, and data reduction for determining in situ modulus of deformation of a rock mass using the rigid plate loading method.

1.2 This test method is designed to be conducted in an adit or small underground chamber; however, with suitable modifications it could be conducted at the surface.

1.3 This test method is usually conducted parallel or perpendicular to the anticipated axis of thrust, as dictated by the design load.

1.4 Time dependent tests can be performed but are to be reported in another standard.

~~1.5 All observed~~ 1.5 Observed and calculated values shall conform to the guidelines for significant digits and rounding established in Practice D 6026.

1.5.1 The method used to specify how data are collected, calculated, or recorded in this standard is not directly related to the accuracy to which the data can be applied in design or other uses, or both. How one applies the results obtained using this standard is beyond its scope.

~~1.6 The values stated in inch-pound units are to be regarded as the standard.~~

1.6 The values stated in inch-pound units are to be regarded as standard. The values given in parentheses are mathematical conversions to SI units that are provided for information only and are not considered standard.

1.7 The references appended to this standard contain further information on this test method.

1.8 *This standard does not purport to address all of the safety concerns, if any, associated with its use. It is the responsibility of the user of this standard to establish appropriate safety and health practices and determine the applicability of regulatory requirements prior to use.* For specific precaution statements, see Section 8.

2. Referenced Documents

2.1 *ASTM Standards:*²

D 653 Terminology Relating to Soil, Rock, and Contained Fluids

~~D 2113 Practice for Diamond Core Drilling for Site Investigation~~ Practice for Rock Core Drilling and Sampling of Rock for Site Investigation

D 4395 Test Method for Determining the In Situ Modulus of Deformation of Rock Mass Using the Flexible Plate Loading Method

D 4403 Practice for Extensometers Used in Rock

D 4879 Guide for Geotechnical Mapping of Large Underground Openings in Rock

D 5079 Practices for Preserving and Transporting Rock Core Samples

D 5434 Guide for Field Logging of Subsurface Explorations of Soil and Rock

D 6026 Practice for Using Significant Digits in Geotechnical Data

D 6032 Test Method for Determining Rock Quality Designation (RQD) of Rock Core

3. Terminology

3.1 For terminology used in this test method, refer to Terminology, D 653.

3.2 *Definitions of Terms Specific to This Standard:*

3.2.1 *deflection*—movement of the rigid plate, mortar pad, or rock in response to and in the same direction as the applied load.

¹ This test method is under the jurisdiction of ASTM Committee D18 on Soil and Rock and is the direct responsibility of Subcommittee D18.12 on Rock Mechanics. Current edition approved July 1, 2004; 2008. Published July 2004; August 2008. Originally approved in 1984. Last previous edition approved in 1998; 2004 as ~~D4394-84(1998); D 4394 – 04.~~

² For referenced ASTM standards, visit the ASTM website, www.astm.org, or contact ASTM Customer Service at service@astm.org. For *Annual Book of ASTM Standards* volume information, refer to the standard's Document Summary page on the ASTM website.

*A Summary of Changes section appears at the end of this standard.

3.2.2 *load*—total force acting on the rock face.

3.2.3 *peak-to-peak modulus of deformation*—the slope of the stress - strain curve line connecting the peaks of the curves obtained from successive pressure cycles (see Fig. 1).

3.2.4 *recovery modulus of deformation*—the tangent modulus of the unloading stress - strain curve. This modulus is usually higher than the other moduli and is used in calculations where unloading conditions exist. The difference between the tangent and recovery moduli indicates that material's capacity of hysteresis or energy dissipation capabilities (see Fig. 2).

3.2.5 *rigid plate*—plate with deflection of less than 0.0001 in. (0.0025 mm) from center to edge of plate, when maximum load is applied.

3.2.6 *secant modulus of deformation*—the slope of the stress-strain curve between zero stress and any specified stress. This modulus should be used for complete the load steps from zero to the desired load (see Fig. 2).

3.2.7 *tangent modulus of deformation*—the slope of the stress - strain curve obtained over the segment of the loading curve judged by the investigator as the most representative of elastic response. It neglects the end effects of the curve and is better suited to small stress changes. The ratio between the secant modulus and the tangent modulus can be used as a means of measuring the stress damage of the material (see Fig. 2).

4. Summary of Test Method

4.1 Areas on two opposing parallel faces of a test adit are flattened and smoothed.

4.2 A mortar pad and rigid metal plate are installed against each face and a hydraulic loading system is placed between the rigid plates.

4.3 If deflection is to be measured within the rock mass, extensometer instruments shall be installed in the rock in accordance with Practice D 4403.

4.4 The two faces are loaded and unloaded incrementally and the deformations of the rock mass at the surfaces and, if desired, within the rock, are measured after each increment. The modulus of deformation is then calculated.

5. Significance and Use

5.1 Results of this type of test method are used to predict displacements in rock mass caused by loads from a structure or from underground construction. It is one of several tests that should be performed. The resulting in situ modulus is commonly less than the elastic modulus determined in the laboratory.

5.2 The modulus is determined using an elastic solution for a uniformly distributed load (uniform stress) over a circular area acting on a semi-infinite elastic medium that produces a constant normal displacement of the loaded surface area of the medium.

5.3 This test method is normally performed at ambient temperature, but equipment can be modified or substituted for operations at other temperatures.

6. Interferences

6.1 A completely inflexible plate used to load the rock face is difficult to construct. However, if the plate is constructed

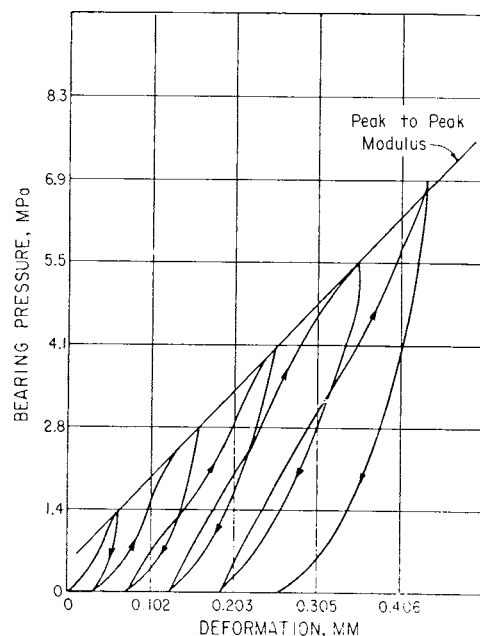

FIG. 1 Rock Surface Deformation as a Function of Bearing Pressure

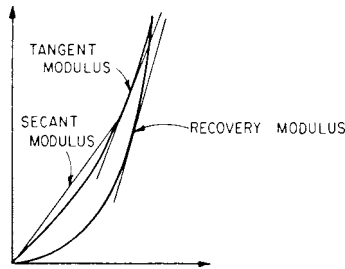

FIG. 2 Relationship Between Tangent, Secant and Recovery Moduli

as rigid as possible, practicable, the rock face is smoothed, and a thin, high-modulus material is used for the pad, the error is minimal.

6.2 The rock under the loaded area is generally not homogeneous, as assumed in theory. Rock will respond to the load according to its local deformational characteristics. Therefore, deflection measurements at discrete points on the rock surface tend to be heavily influenced by the deformational characteristics of the rock mass at that location and may give results that are unrepresentative of the rock mass. The use of the average plate deflection will mitigate this problem.

6.3 Measurement of the deflection within the rock mass can utilize a finite gauge length to reflect the average rock mass deformation properties between the measuring points. This approach entails three drawbacks, however. First, the rock mass is tested at very low stress levels unless the measurement points are very close to the rock surface, and because of this, the same problems as with surface measurements occur. Tests at low stress levels may give unrealistically low modulus values because microfractures, joints, and other discontinuities in the rock are open. Secondly, the disturbance caused by implanting the deflection transducer in the rock mass is difficult to evaluate. The techniques in this test method are designed to produce minimal disturbance. Thirdly, in rocks with very high modulus, the accuracy of the instruments may be insufficient to provide reliable results.

6.4 Time-rate of loading has negligible influence on the modulus.

6.5 Calculations neglect the stress history of the rock.

6.6 This test method is insensitive to Poisson's ratio.

6.7 Poisson's ratio must be assumed or obtained from laboratory testing.

7. Apparatus

7.1 Equipment necessary for accomplishing this test method includes items for: preparing the test site, drilling and logging the instrumentation holes, measuring the rock deformation, applying and restraining test loads, recording test data, and transporting various components to the test site.

7.2 *Test Site Preparation Equipment*— This shall include an assortment of excavation tools, such as drills and chipping hammers. Blasting shall not be allowed during final preparation of the test site. The drill for the instrumentation holes shall, if possible, practicable, have the capability of retrieving cores from depths of at least about 30 ft (10 m).

7.3 *Borehole Viewing Device*—Some type of device is desirable for examination/observation of the instrumentation holes to compare and verify geologic features observed in the core if core recovery is poor or if it is not feasible to retrieve oriented cores.

7.4 *Deformation Measuring Instruments*— Instruments for measuring deformations shall include a reliable multiple-position borehole extensometer (MPBX) for each instrumentation hole and a tunnel diameter gauge. For surface measurements, dial gages or linear variable differential transformers (LVDTs) are generally used. An accuracy of at least ± 0.0001 in. (0.0025 mm), including the error of the readout equipment, and a sensitivity of at least 0.00005 in. (0.0013 mm) is recommended. Errors in excess of 0.0004 in. (0.01 mm) can invalidate test results when the modulus of rock mass exceeds 5×10^6 psi (3.5×10^4 MPa).

7.5 *Loading Equipment*—The loading equipment includes the device for applying the load and the reaction members (usually thick-walled aluminum or steel pipes) which transmit the load. Hydraulic rams or flatjacks are usually used to apply the load hydraulically with sufficient capability and volume to apply and maintain desired pressures to within 3 %. If flatjacks are used they should have sufficient range to allow for deflection of the rock and should be constructed so that the two main plates move apart in a parallel manner over the usable portion of the loading range. A spherical bearing of suitable capacity should be coupled to one of the bearing plates.

7.6 *Load Cells and Transducers*—A load cell is recommended to measure the load on the bearing plate. An accuracy of at least around ± 1000 lbf (± 4.4 kN), including errors introduced by the readout system, and a sensitivity of at least 500 lbf (2.2 kN) are recommended. Alternatively, a pressure gauge or transducer may be used to monitor hydraulic pressure for calculation of load, provided the device can measure the load to the same specifications as the load cell. An accuracy of at least ± 20 psi (± 0.14 MPa), including error introduced by readout equipment, and a sensitivity of at least 10 psi (0.069 MPa). If a hydraulic ram is used, the effects of ram friction shall be determined. If flatjacks are used, care shall be taken that the jacks do not operate at the upper end of their range.

7.7 *Bearing Pads*—The bearing pads shall have a modulus of elasticity of at least around 4×10^6 psi (3×10^4 MPa) and shall be capable of conforming to the rock surface and bearing plate. High-early strength grout or molten sulfur bearing pads are recommended.

7.8 *Bearing Plates*—The bearing plates shall approximate a rigid die as closely as practical. A bearing plate that has been found satisfactory is shown on Fig. 3. Although the exact design and materials may differ, the stiffness of the bearing plate shall at least be the minimum stiffness necessary to ~~produce~~ not produce measurable deflection of the plate under maximum load.

8. Safety Hazards

8.1 ~~All personnel~~ 8.1 Personnel involved in performing the test shall be formally prequalified under the quality assurance procedures listed in Annex A1.

8.2 Verify the compliance of all equipment and apparatus with the performance specifications in Section 7. If ~~no~~ requirements are not stated, the manufacturer’s specifications for the equipment may be appropriate as a guide, however, care ~~must~~ should be taken for sufficient performance. Performance verification is generally done by calibrating the equipment and measurement system. Accomplish calibration and documentation in accordance with the quality assurance procedures.

8.3 Enforce safety by applicable safety standards. Pressure lines ~~must~~ should be bled of air to preclude violent failure of the pressure system. Total deformation should not exceed the expansion capabilities of the flatjacks; normally this is approximately 3 % of the diameter of a metal jack.

9. In-Situ Conditions

NOTE 1—The guidelines presented in this section are the domain of the agency or organization requesting the testing and are intended to facilitate definition of the scope and development of site-specific requirements for the testing program as a whole.

9.1 Test each structurally distinctive zone of rock mass selecting areas that are geologically representative of the mass. Test those portions of the rock mass with features such as faults, fracture zones, cavities, inclusions, and the like to evaluate their effects. Design the testing program so that effects of local geology can be clearly distinguished.

9.2 ~~The~~ 9.2 The size of the plate will be determined by local geology, pressures to be applied, and the size of the adit to be tested. These parameters should be considered prior to excavation of the adit. ~~Optimum~~ Acceptable adit dimensions are approximately six

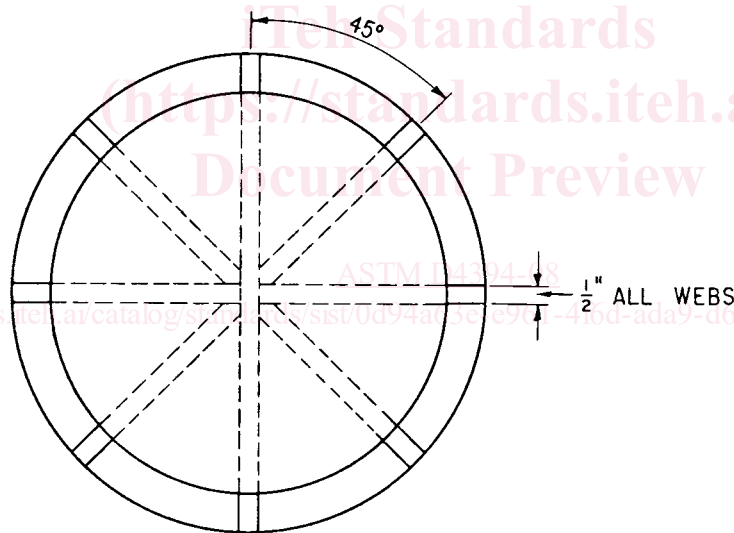

NOTE: ALL JOINTS FULLY WELDED

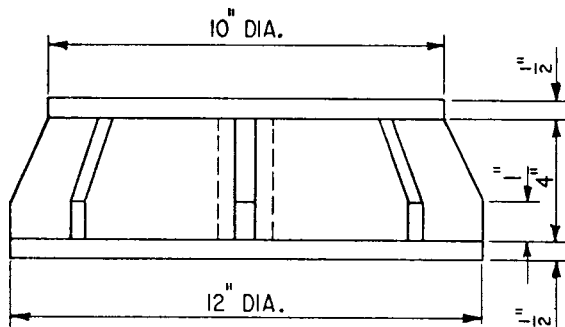

FIG. 3 Rigid Bearing Plate for 12 in. Diameter Test

times the plate diameter; recommended plate diameter is commonly 1½ to 3¼ ft (0.5 to 1 m). Other sizes are used depending upon site specifics. A map of the adit and test site shall be prepared in accordance with Guide D 4879.

9.3 The ~~effects~~ effects of anisotropy should be investigated by appropriately oriented tests: for example, parallel and perpendicular to the bedding of a sedimentary sequence, or parallel and perpendicular to the long axes of columns in a basalt flow.

9.4 Tests shall be performed at a site not affected by structural changes resulting from excavations of the adit. The zone of rock that contributes to the measured deflection during the plate loading test depends on the diameter of the plate and the applied load. Larger plates and higher loads measure the response of rock further away from the test adit. Thus, if the rock around the adit is damaged by the excavation process, and the deformational properties of the damaged zone are the primary objective of the test program, small-diameter plate tests on typically excavated surfaces are adequate. If the ~~undisturbed intact~~ in-situ modulus is desired, larger diameter plates and higher loads may be used, although practical considerations often limit the size of the equipment. Alternatively, careful excavation procedures, such as presplitting or other types of smooth-wall blasting, may be employed in the test area to limit damage to the rock and the resulting need for large plates and loads.

9.5 ~~Cores, if any, shall~~ 9.5 Cores should be preserved, logged, and tested for rock quality designation (RQD), fracture spacing and orientation, condition of joint surfaces, strength, and deformation. In lieu of specific requirements, test methods D 2113, D 5079, D 5434, and D 6032 shall be considered the minimum requirements.

9.6 Site conditions may dictate that site preparation and pad construction be performed immediately after excavation.

10. Procedure

~~10.1 Conduct~~ 10.1 Conduct the test across a “diameter” or chord of the adit with the two test surfaces nearly parallel and in planes oriented perpendicular to the thrust of the loading assembly. A schematic of an ~~optimum acceptable~~ test setup is shown in Fig. 4. A ~~properly located~~ wooden platform (not shown) allows for ease of construction and alignment of ~~all~~ test components.

10.2 Bearing Surface Preparation :

10.2.1 Method—Prepare the surface by a method that will cause minimal damage to the finished rock surface. Drilling ~~may be required~~ is advised to reach uniform depth. Residual rock between the drill holes may be removed by burnishing or moving the bit back and forth until a smooth face is achieved. Alternatively, in hard, competent rock, controlled blasting with very small charges ~~may be required~~ is advised to remove the residual materials. In weaker materials, coarse grinding or cutting devices may be used.

10.2.2 Size—The prepared rock surface shall extend ~~at least one-half~~ the diameter of the bearing plate beyond the edge of the plate.

10.2.3 Rock Quality—To the extent ~~possible, practicable,~~ prepare the bearing surface in sound rock. Remove loose and broken rock from the excavation. Deeper breaks may be detected by a dull hollow sound when the rock surface is struck with a hammer; remove such material.

10.2.4 Smoothness—The prepared rock face shall be as smooth as practicable. ~~In no case shall the~~ The deviation from a plane between the highest and lowest points ~~should not exceed~~ 1 in. (25 mm).

<https://standards.iteh.ai/catalog/standards/sist/0d94a63e-e961-4f6d-ada9-d686b8fd0ab6/astm-d4394-08>

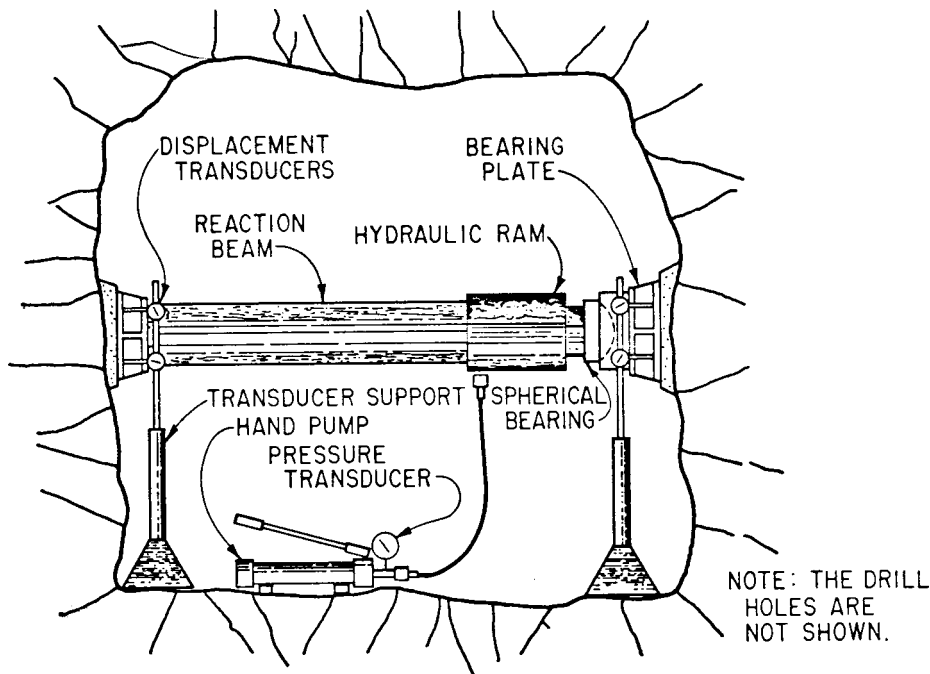

FIG. 4 Typical Rigid Plate Bearing Test Setup Schematic

10.2.5 *Cleaning*—After the surface has been prepared, scrub and rinse it with clean water to remove any loose particles or dirt caused by the smooth operation.

10.3 Construct detailed geometrical and geological plan and cross sectional views of the test site.

10.4 *Bearing Pad Construction*—Construct the bearing pad, with the bearing plate in position, by pouring the pad material between the rock surface and the plate. Contain the pad material by suitable form work around the edges of the plate. The only exception to this method is for near vertical tests where cement pads are used. In this case, the lower bearing plate may be placed directly upon the pad prior to curing. ~~In all cases, exercise~~ Exercise care to avoid air pockets or other cavities within the pad. The thickness of the pad should be ~~no more less than 1.5 in./ft (38 mm/0.305 m)~~ 12.5 % of the flatjack diameter at any point ~~most points~~. The dimensional requirements are shown in Fig. 5.

10.5 *Measuring Points*:

10.5.1 *Surface Measurements*—Take deformation measurements on the rock surface at the edge of the bearing pad at a minimum of six equally spaced intervals around the edge of each pad. Secure reference pads to the rock surface at surface measurement points. Measure the deflection of the bearing plate in ~~at least~~ three equally spaced locations around the plate. The displacement transducers should be supported so that only the deflection of the rock itself is measured. Generally, this means mounting the transducers from supports located outside the zone of influence of the test. ~~In no case~~ The transducers should ~~the transducers~~ not be mounted on the loading apparatus. Install cross tunnel measurement points and equipment such as described in Practice D 4403.

10.5.2 *Measurements Within the Rock Mass*:

10.5.2.1 If deformation measurements in the rock mass are ~~required~~ necessary they shall be taken along a line within 5° of the direction of loading and not located ~~no~~ farther from center line than 10 % of the width of the bearing pad.

~~10.5.2.2~~ 10.5.2.2 The holes for instruments shall be as small as feasible. Holes should be diamond-rotary drilled on opposing surfaces and continuously cored and logged. Drill core may need to be preserved for laboratory testing in accordance with Practice D 5079. ~~All pertinent~~ Pertinent drill hole data shall be added to the maps in 10.3.

~~10.5.2.3~~ 10.5.2.3 Select the location of each measurement point by examining the rock core and inspecting the borehole with a borescope or other suitable device. In general, place measuring points on either side of joints, thin beds, seams, and the like. Place at least two measuring points within one plate diameter of the rock surface. Locate the deepest two measuring points at ~~least~~ roughly six plate diameters from the bearing surface outside the calculated zone of measured influence. Other instrument arrangements may be appropriate for specific geologic conditions or project objectives.

10.5.2.4 The installation and recording procedures for the measuring instruments or extensometers are presented in Practice D 4403. The extensometer leads extend out from the hole and exit out the side of the bearing pad. Prior to casting the pads, shield the leads with polyvinyl chloride or rubber tubing.

10.5.2.5 The accuracy and sensitivity of the instruments chosen shall be compatible with the anticipated modulus values. The error associated with a single test shall be evaluated. This includes the combined effects of ~~all~~ transducers, power supplies, readout devices, and the like.

10.6 *Pretest Check*—Electronically or mechanically check ~~all~~ the components of the instrumentation after they are installed in the drill holes. After the loading and restraining components are installed, make another check of the instrumentation. Make ~~final~~ checks of ~~all~~ mechanical, hydraulic, and electronic components after the concrete pads are placed and again before the first load increment is applied.

10.7 *Pressurization Cycles*:

10.7.1 Observations during the first pressure cycle can be used to modify time rate requirements for successive cycles.

10.7.2 In general, five pressure cycles to peak pressure, each in ten increments at 1 min per increment, are adequate. The middle cycle shall be approximately at design load with the upper cycle approximately two times the design load, if ~~possible~~ practicable.

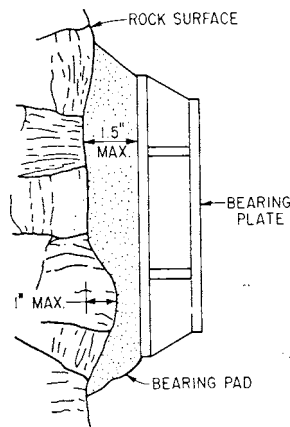

FIG. 5 Allowable Dimensions for Rock Surface and Bearing Pad