



Designation: D7070-04

## Standard Test Method for Designation: D 7070 – 08

### Standard Test Methods for Creep of Rock Core Under Constant Stress and Temperature<sup>1</sup>

This standard is issued under the fixed designation D 7070; the number immediately following the designation indicates the year of original adoption or, in the case of revision, the year of last revision. A number in parentheses indicates the year of last reapproval. A superscript epsilon ( $\epsilon$ ) indicates an editorial change since the last revision or reapproval.

#### 1. Scope\*

~~1.1 This~~ 1.1 These test methods covers the creep behavior of intact soft and hard rock core in fixed states of stress and temperature. ~~It specifies~~ They specify the apparatus, instrumentation, and procedures for determining the strain as a function of time under sustained load. Hard rocks are those with a maximum axial strain at failure of less than 2 %. Soft rocks include such materials as salt and potash, which often exhibit very large strain at failure.

1.2 This standard replaces and combines the following Standard Test Methods now to be referred to as Methods:

Method 'A' (D 5341 Creep of Hard Rock Core Specimens in Uniaxial Compression at Ambient/Elevated Temperatures);

Method 'B' (D 4405 Creep of Soft Rock Core Specimens in Uniaxial Compression at Ambient or Elevated Temperature); and

Method 'C' (D 4406 Creep of Rock Core Specimens in Triaxial Compression at Ambient or Elevated Temperature).

1.3 All observed and calculated values shall conform to the guidelines for significant digits and rounding established in Practice D 6026.

1.3.1 The method used to specify how data are collected, calculated, or recorded in this standard is not directly related to the accuracy to which the data can be applied in design or other uses, or both. How one applies the results obtained using this standard is beyond its scope.

~~1.3.2 The values stated in SI units are to be regarded as the standard.~~

~~1.4~~

1.4 The values stated in SI units are to be regarded as the standard. The values given in parentheses are mathematical conversions to inch-pound units that are provided for information only and are not considered standard.

1.5 This standard does not purport to address all of the safety concerns, if any, associated with its use. It is the responsibility of the user of this standard to establish appropriate safety and health practices and to determine the applicability of regulatory limitations prior to use. For specific precautionary statements, see Section 7.

#### 2. Referenced Documents

##### 2.1 ASTM Standards:<sup>2</sup>

D 653 ~~Standard Terminology~~ Terminology Relating to Soil, Rock, and Contained Fluids

D 2113 ~~Practice for Diamond Core Drilling for Site Investigation~~ Practice for Rock Core Drilling and Sampling of Rock for Site Investigation

D 2216 ~~Test Method for Laboratory Determination of Water (Moisture) Content of Soil and Rock~~ Test Methods for Laboratory Determination of Water (Moisture) Content of Soil and Rock by Mass

D 3740 Practice for Minimum Requirements for Agencies Engaged in Testing and/or Inspection of Soil and Rock as Used in Engineering Design and Construction

D 4543 ~~Practice for Preparing Rock Core Specimens and Determining Dimensional and Shape Tolerances~~ Practices for Preparing Rock Core as Cylindrical Test Specimens and Verifying Conformance to Dimensional and Shape Tolerances

D 5079 Practices for Preserving and Transporting Rock Core Samples

<sup>1</sup> This test method is under the jurisdiction of ASTM Committee and is the direct responsibility of Subcommittee D18.12 on Rock Mechanics.

Current edition approved Sept. 1, 2004. Published September 2004.

<sup>1</sup> This test method is under the jurisdiction of ASTM Committee D18 and is the direct responsibility of Subcommittee D18.12 on Rock Mechanics.

Current edition approved July 1, 2008. Published August 2008. Originally approved in 2004. Last previous edition approved in 2004 as D 7070 – 04.

<sup>2</sup> For referenced ASTM standards, visit the ASTM website, www.astm.org, or contact ASTM Customer Service at service@astm.org. For Annual Book of ASTM Standards volume information, refer to the standard's Document Summary page on the ASTM website.

\*A Summary of Changes section appears at the end of this standard.

D 6026 Practice for Using Significant Digits in Geotechnical Data

E 4 Practices for Load Force Verification of Testing Machines

E 122 Practice for Choice of Sample Size to Estimate a Measure of Quality for a Lot or Process—Practice for Calculating Sample Size to Estimate, With Specified Precision, the Average for a Characteristic of a Lot or Process

### 3. Terminology

3.1 Refer to Terminology D 653 for specific definitions.

### 4. Summary of Test Method

4.1 A section of rock core specimen is cut to length, and the ends are machined flat to produce a cylindrical test specimen. ~~A uniaxial~~ For the Uniaxial Compression Method, the specimen is placed in a loading frame. ~~A triaxial~~ For Triaxial Compression Method, the specimen is placed in a triaxial loading chamber and subjected to confining pressure. If required, the specimen is heated to the desired test temperature. Axial load is applied rapidly to the specimen and sustained. Deformation is monitored as a function of elapsed time.

### 5. Significance and Use

5.1 There are many underground structures that are created for permanent or long-term use. Often, these structures are subjected to an approximately constant load. Creep tests provide quantitative parameters for stability analysis of these structures.

5.2 The deformation and strength properties of rock cores measured in the laboratory usually do not accurately reflect large-scale in situ properties, because the latter are strongly influenced by joints, faults, inhomogeneities, weakness planes, and other factors. Therefore, laboratory values for intact specimens must be employed with proper judgment in engineering applications.

NOTE 1—Notwithstanding the statements on precision and bias contained in this test method; the precision of this test method is dependent on the competence of the personnel performing it, and the suitability of the equipment and facilities used. Agencies that meet the criteria of Practice D 3740 are generally considered capable of competent and objective testing. Users of this test method are cautioned that compliance with Practice D 3740 does not in itself assure reliable testing. Reliable testing depends on many factors; Practice D 3740 provides a means of evaluating some of these factors.

### 6. Apparatus

6.1 *Loading Device*—The loading device shall be of sufficient capacity to apply load at a rate conforming to the requirements specified in 10.6 and shall be able to maintain the specified load within 2%. It shall be verified at suitable time intervals in accordance with the procedures given in Practices E 4 and comply with the requirements prescribed in this test method.

NOTE 2—By definition, creep is the time-dependent deformation under constant stress. The loading device is specified to maintain constant axial load and therefore, constant engineering stress. The true stress, however, decreases as the specimen deforms and the cross-sectional area increases. Because of the associated experimental ease, constant load testing is recommended. However, the procedure permits constant true-stress testing, provided that the applied load is increased with specimen deformation so that true stress is constant within 2%.

6.2 *Triaxial Apparatus*—The triaxial apparatus shall consist of a chamber in which the test specimen may be subjected to a constant lateral fluid pressure and the required axial load. The apparatus shall have safety valves, suitable entry ports for filling the chamber, and associated hoses, gauges, and valves as needed. Fig. 1 shows a typical test apparatus and associated equipment.

6.3 *Triaxial Flexible Membrane*—This membrane encloses the rock specimen and extends over the platens to prevent penetration by the confining fluid. A sleeve of natural or synthetic rubber or plastic is satisfactory for room temperature tests; however, metal or high-temperature rubber jackets such as viton are usually required for elevated temperature tests. The membrane shall be inert relative to the confining fluid and shall cover small pores in the sample without rupturing when confining pressure is applied. Plastic or silicone rubber coatings may be applied directly to the sample, provided these materials do not penetrate and strengthen the specimen. Care must be taken to form an effective seal where the platen and specimen meet. Membranes formed by coatings shall be subject to the same performance requirements as elastic sleeve membranes.

6.4 *Triaxial Pressure-Maintaining Device*—A hydraulic pump, pressure intensifier, or other system of sufficient capacity to maintain constant the desired lateral pressure. The pressurization system shall be capable of maintaining the confining pressure constant to within  $\pm 1\%$  throughout the test. The confining pressure shall be measured with a hydraulic pressure gauge or electronic transducer having an accuracy of at least  $\pm 1\%$  of the confining pressure, including errors due to readout equipment, and a resolution of at least 0.5% of the confining pressure.

6.5 *Confining-Pressure Fluids*—For room temperature tests, hydraulic fluids compatible with the pressure-maintaining device should be used. For elevated temperature tests the fluid must remain stable at the temperature and pressure levels designated for the test.

6.6 *Elevated-Temperature Enclosure*—The elevated temperature enclosure may be either an enclosure that fits in the loading apparatus, an internal system that fits in the triaxial apparatus, or an external system encompassing the complete test apparatus. The enclosure may be equipped with humidity control for testing specimens in which the moisture content is to be controlled. For high temperatures, a system of heaters, insulation, and temperature measuring devices are normally required to maintain the specified temperature. Temperature shall be measured at three locations, with one sensor near the top, one at midheight, and one

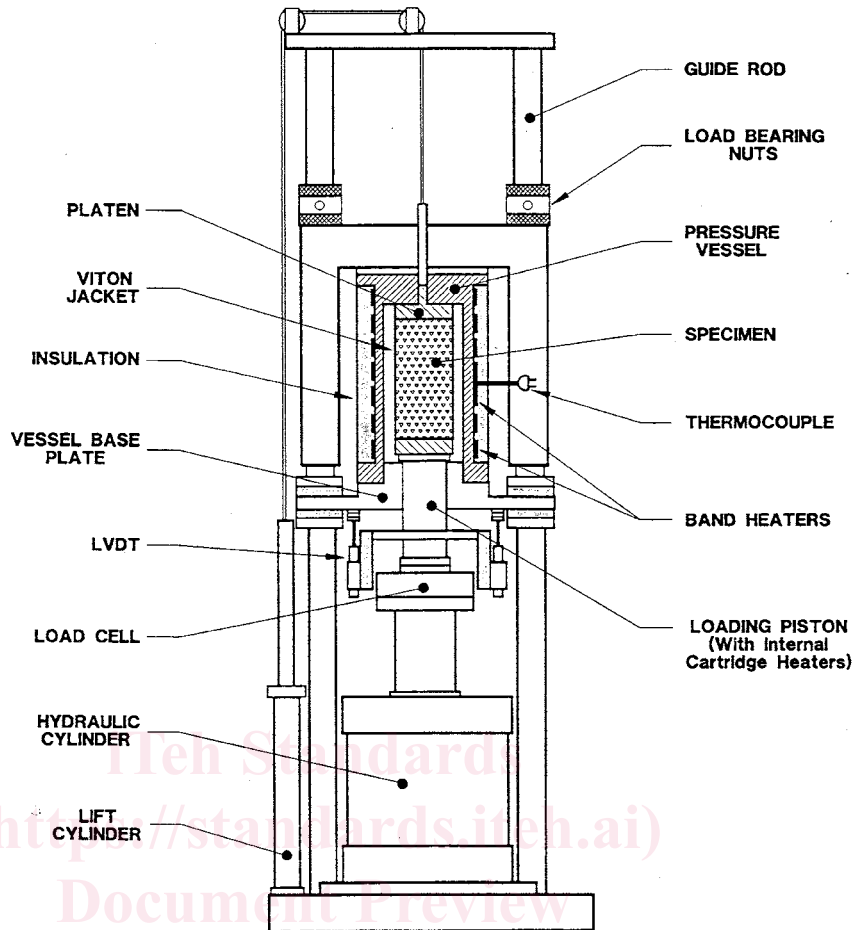

FIG. 1 Test Apparatus

ASTM D7070-08

near the bottom of the specimen. The average specimen temperature based on the midheight sensor shall be maintained to within  $\pm 1^\circ\text{C}$  of the required test temperature. The maximum temperature difference between the midheight sensor and either end sensor shall not exceed  $3^\circ\text{C}$  when measured under steady state temperature conditions as defined in Section 6.6.

NOTE 3—An alternative to measuring the temperature at three locations along the specimen during the test is to determine the temperature distribution in a substitute specimen that has temperature sensors located in drill holes at a minimum of six positions: along both the centerline and specimen periphery at midheight and at each end of the specimen. The temperature controller set point shall be adjusted to obtain steady-state temperatures (see Section 10.5) in the substitute specimen that meet the temperature requirements at each test temperature (the centerline temperature at midheight shall be within  $\pm 1^\circ\text{C}$  of the required test temperature, and all other specimen temperatures shall not deviate from this temperature by more than  $3^\circ\text{C}$ ). The relationship between controller set point and substitute specimen temperature can be used to determine the specimen temperature during testing, provided that the output of the temperature feedback sensor (or other fixed-location temperature sensor in the triaxial apparatus) is maintained constant within  $\pm 1^\circ\text{C}$  of the required test temperature. The relationship between temperature controller set point and steady-state specimen temperature shall be verified periodically. The substitute specimen is used solely to determine the temperature distribution in a specimen in the triaxial apparatus; it is not to be used to determine creep behavior.

6.7 *Temperature Measuring Device*—Special limits-of-error thermocouples or platinum resistance thermometers (RTDs) having accuracies of at least  $\pm 1^\circ\text{C}$  with a resolution of  $0.1^\circ\text{C}$ .

6.8 *Platens*—Two steel platens are used to transmit the axial load to the ends of the specimen. They shall have a hardness of not less than 58 HRC. One of the platens should be spherically seated and the other a plain rigid platen. The bearing faces shall not depart from a plane by more than 0.015 mm when the platens are new and shall be maintained within a permissible variation of 0.025 mm. The diameter of the spherical seat shall be at least as large as that of the test specimen but shall not exceed twice the diameter of the test specimen. The center of the sphere in the spherical seat shall coincide with that of the bearing face of the specimen. The spherical seat shall be properly lubricated to ensure free movement. The movable portion of the platen shall be held closely in the spherical seat, but the design shall be such that the bearing face can be rotated and tilted through small angles in any direction. If a spherical seat is not used, the bearing faces of the platens shall be parallel to 0.0005 mm/mm of platen diameter.

6.8.1 *Hard Rock Specimens*—The platen diameter shall be at least as great as the specimen but shall not exceed the specimen diameter by more than 1.50 mm. This platen diameter shall be retained for a length of at least one-half the specimen diameter.