



SLOVENSKI STANDARD
oSIST prEN ISO 17872:2018
01-oktober-2018

Barve in laki - Smernice za uvajanje sledi rezov v premazih na kovinskih ploščah za preskušanje odpornosti proti koroziji (ISO/DIS 17872:2018)

Paints and varnishes - Guidelines for the introduction of scribe marks through coatings on metallic panels for corrosion testing (ISO/DIS 17872:2018)

Beschichtungsstoffe - Leitfaden zum Anbringen von Ritzen durch eine Beschichtung auf Metallplatten für Korrosionsprüfungen (ISO/DIS 17872:2018)

Peintures et vernis - Lignes directrices pour la production de rayures au travers du revêtement de panneaux métalliques en vue des essais de corrosion (ISO/DIS 17872:2018)

Ta slovenski standard je istoveten z: prEN ISO 17872

ICS:

87.040

Barve in laki

Paints and varnishes

oSIST prEN ISO 17872:2018

en,fr,de

DRAFT INTERNATIONAL STANDARD

ISO/DIS 17872

ISO/TC 35/SC 9

Secretariat: BSI

Voting begins on:
2018-08-23Voting terminates on:
2018-11-15

Paints and varnishes — Guidelines for the introduction of scribe marks through coatings on metallic panels for corrosion testing

Peintures et vernis — Lignes directrices pour la production de rayures au travers du revêtement de panneaux métalliques en vue des essais de corrosion

ICS: 87.040

iTeh STANDARD PREVIEW
(standards.iteh.ai)

[SIST EN ISO 17872:2020](https://standards.iteh.ai/catalog/standards/sist/3cabb788-786b-4670-a864-e4be8a432dd0/sist-en-iso-17872-2020)

<https://standards.iteh.ai/catalog/standards/sist/3cabb788-786b-4670-a864-e4be8a432dd0/sist-en-iso-17872-2020>

THIS DOCUMENT IS A DRAFT CIRCULATED FOR COMMENT AND APPROVAL. IT IS THEREFORE SUBJECT TO CHANGE AND MAY NOT BE REFERRED TO AS AN INTERNATIONAL STANDARD UNTIL PUBLISHED AS SUCH.

IN ADDITION TO THEIR EVALUATION AS BEING ACCEPTABLE FOR INDUSTRIAL, TECHNOLOGICAL, COMMERCIAL AND USER PURPOSES, DRAFT INTERNATIONAL STANDARDS MAY ON OCCASION HAVE TO BE CONSIDERED IN THE LIGHT OF THEIR POTENTIAL TO BECOME STANDARDS TO WHICH REFERENCE MAY BE MADE IN NATIONAL REGULATIONS.

RECIPIENTS OF THIS DRAFT ARE INVITED TO SUBMIT, WITH THEIR COMMENTS, NOTIFICATION OF ANY RELEVANT PATENT RIGHTS OF WHICH THEY ARE AWARE AND TO PROVIDE SUPPORTING DOCUMENTATION.

This document is circulated as received from the committee secretariat.

ISO/CEN PARALLEL PROCESSING



Reference number
ISO/DIS 17872:2018(E)

© ISO 2018

iTeh STANDARD PREVIEW (standards.iteh.ai)

SIST EN ISO 17872:2020

<https://standards.iteh.ai/catalog/standards/sist/3cabb788-786b-4670-a864-e4be8a432dd0/sist-en-iso-17872-2020>



COPYRIGHT PROTECTED DOCUMENT

© ISO 2018

All rights reserved. Unless otherwise specified, or required in the context of its implementation, no part of this publication may be reproduced or utilized otherwise in any form or by any means, electronic or mechanical, including photocopying, or posting on the internet or an intranet, without prior written permission. Permission can be requested from either ISO at the address below or ISO's member body in the country of the requester.

ISO copyright office
CP 401 • Ch. de Blandonnet 8
CH-1214 Vernier, Geneva
Phone: +41 22 749 01 11
Fax: +41 22 749 09 47
Email: copyright@iso.org
Website: www.iso.org

Published in Switzerland

Contents

| | Page |
|--|-----------|
| Foreword..... | iv |
| Introduction..... | v |
| 1 Scope..... | 1 |
| 2 Normative references..... | 1 |
| 3 Terms and definitions..... | 1 |
| 4 Scribe marks..... | 1 |
| 5 Apparatus..... | 5 |
| 6 Test panels..... | 5 |
| 7 Procedure..... | 5 |
| 8 Verification of the scribing tool..... | 5 |
| 9 Report..... | 5 |
| Annex A (informative) Scribing tools..... | 7 |
| Annex B (informative) Examples of possible different results in one corrosion test when using different scribing tools..... | 17 |
| Bibliography..... | 22 |

iTeh STANDARD PREVIEW
(standards.iteh.ai)

[SIST EN ISO 17872:2020](https://standards.iteh.ai/catalog/standards/sist/3cabb788-786b-4670-a864-e4be8a432dd0/sist-en-iso-17872-2020)

<https://standards.iteh.ai/catalog/standards/sist/3cabb788-786b-4670-a864-e4be8a432dd0/sist-en-iso-17872-2020>

ISO/DIS 17872:2018(E)

Foreword

ISO (the International Organization for Standardization) is a worldwide federation of national standards bodies (ISO member bodies). The work of preparing International Standards is normally carried out through ISO technical committees. Each member body interested in a subject for which a technical committee has been established has the right to be represented on that committee. International organizations, governmental and non-governmental, in liaison with ISO, also take part in the work. ISO collaborates closely with the International Electrotechnical Commission (IEC) on all matters of electrotechnical standardization.

The procedures used to develop this document and those intended for its further maintenance are described in the ISO/IEC Directives, Part 1. In particular the different approval criteria needed for the different types of ISO documents should be noted. This document was drafted in accordance with the editorial rules of the ISO/IEC Directives, Part 2 (see www.iso.org/directives).

Attention is drawn to the possibility that some of the elements of this document may be the subject of patent rights. ISO shall not be held responsible for identifying any or all such patent rights. Details of any patent rights identified during the development of the document will be in the Introduction and/or on the ISO list of patent declarations received (see www.iso.org/patents).

Any trade name used in this document is information given for the convenience of users and does not constitute an endorsement.

For an explanation on the voluntary nature of standards, the meaning of ISO specific terms and expressions related to conformity assessment, as well as information about ISO's adherence to the World Trade Organization (WTO) principles in the Technical Barriers to Trade (TBT) see the following URL: www.iso.org/iso/foreword.html.

This document was prepared by Technical Committee ISO/TC 35, *Paints and varnishes*, Subcommittee SC 9, *General test methods of paints and varnishes*.

This second edition cancels and replaces the first edition (ISO 17872:2007), which has been technically revised.

The main changes compared to the previous edition are as follows:

- [Clause 2](#) on "Normative references" and [Clause 3](#) on "Terms and definitions" have been added;
- figures of L-shaped and diagonal shaped scribes have been added;
- a second variation of the cross-sectional shape of U-shape scribe mark has been added in [Figure 2](#);
- V-shape replaceable blade, disc milling cutter, graver and ceramic knife have been added to the list of possible cutting tools;
- pictures of the cross sections have been added to the corresponding cutting tools;
- the examples for cutting tools in [Table A.1](#) have been grouped to knife or blade tools, pencil type tools and milling machines;
- the original [Annex B](#) has been replaced by a new annex on examples of possible different results in one corrosion test when using different scribing tools.

Introduction

Many International Standards deal with corrosion testing, where scribe marks are introduced through a coating to a metallic substrate. However, the method of scribe-mark introduction (scribing pattern, tools, etc.) is not standardized across these standards.

The main purposes of an intentionally inflicted damage in a coating prior to corrosion testing are as follows:

- a) to simulate and to investigate how adhesion of a coating originating from an artificial damage after exposure is ensured;
- b) to obtain an accelerated response during a corrosion test, e.g. at quality control during production;
- c) to investigate the general durability of a coating by observation of the rate of corrosion at a damage spread after exposure.

Preliminary investigations have shown that several variants, both in terms of shape and dimensions, of scribing tools are used. This variation occurs both across countries and within countries. The effect of using different tools is the production of scribe marks with different cross-sectional shape, depth and exposed metal area. These differences will greatly affect test results obtained during corrosion tests, as the intention of introducing scribe marks into a coating system is such that oxygen and the electrolyte present during exposure testing can obtain access to a well-defined and active metal surface.

The actual method used to introduce a scribe mark depends on the coating type and thickness. However, in all cases it is preferable if the cross-section is as smooth as possible, the metallic substrate is exposed evenly and no coating remains on the exposed substrate.

(standards.iteh.ai)

[SIST EN ISO 17872:2020](https://standards.iteh.ai/catalog/standards/sist/3cabb788-786b-4670-a864-e4be8a432dd0/sist-en-iso-17872-2020)

<https://standards.iteh.ai/catalog/standards/sist/3cabb788-786b-4670-a864-e4be8a432dd0/sist-en-iso-17872-2020>

Paints and varnishes — Guidelines for the introduction of scribe marks through coatings on metallic panels for corrosion testing

1 Scope

This document describes methods of scribing coated steel or test-pieces for corrosion tests, where the coating system is applied at dry film thicknesses of less than 500 µm. It is intended as a guideline only, being based on the results of a collaborative trial with no subsequent corrosion testing having been carried out to determine the suitability of the introduced scribe marks for such tests.

This document covers the scribing of metallic panels or test pieces (chemically treated or not) made from:

- steel,
- galvanized steel,
- aluminium alloys,
- magnesium alloys.

It does not cover the scribing of electroplated metal or clad aluminium panels.

2 Normative references

The following documents are referred to in the text in such a way that some or all of their content constitutes requirements of this document. For dated references, only the edition cited applies. For undated references, the latest edition of the referenced document (including any amendments) applies.

ISO 4618, *Paints and varnishes — Terms and definitions*

3 Terms and definitions

For the purposes of this document, the terms and definitions given in ISO 4618 apply.

ISO and IEC maintain terminological databases for use in standardization at the following addresses:

- IEC Electropedia: available at <http://www.electropedia.org/>
- ISO Online browsing platform: available at <http://www.iso.org/obp>

4 Scribe marks

Different scribe marks create different results depending on the used corrosion test.

The scribing method greatly affects how the corrosion process occurs and the reproducibility when tests are repeated under the same conditions. In order to obtain results with high accuracy and reproducibility, accurate and consistent scribing is required.

If not otherwise agreed or specified, a scribe mark is made as described in [Figure 1a](#)) to e) through the coating to the metal substrate according to the agreed conditions. Typically, the suitable length of the scribed lines is in the range of 50 mm to 70 mm, depending on the coating thickness and the expected amount of corrosion.

ISO/DIS 17872:2018(E)

The length of the scribe mark should be significantly more than the expected creep resulting from the corrosion test carried out. It should give an overview what happens on the surface of the system. Too short scribing lengths have an impact on the results.

The width of the scribe mark can also affect the result of a corrosion test. The smaller the width, the stronger is the tendency for the exposed metal surface to be passivated by deposition of sparingly soluble corrosion products. Kind and thickness of an organic coating can have an impact to the scribing line in that way that the scribing line closes itself partially in kind of a capillary. Therefore no or less electrolytes and/or oxygen could reach the metal surface. It is therefore important to select a scribing tool which will provide a suitable scribe width for the corrosion test being carried out.

The orientation of the scribed lines is often significant in terms of affecting corrosion test results. On panels with a slight inclination from the vertical, e.g. for salt-spray tests, more salt is collected in a horizontally exposed scribe mark. Also, a horizontally exposed scribe mark will generate an even salt distribution, whereas a diagonal, or more particularly a vertical, scribe mark tends to generate a gradient, with an increasing amount of salt along the lower edge of the scribe mark. An increased amount of salt usually leads to an increased corrosion rate, but on coated steel, high salt concentration might have an inhibiting effect on corrosion since the formed corrosion products are very dense.

Milled/rolled aluminium substrates shall get basically two scribes in different orientations to consider the influence of the milling/rolling direction to the corrosion result.

The cross-section of the scribe mark should be as uniform as possible along its entire length. The coating should be cut smoothly along the direction of the scribe mark. The cross-sectional shape of the scribe may be either "V" or "U" shaped, depending upon the tool used, and should be such that for a "V"-shaped cut $a > b > c$ and for a "U"-shaped cut $a > b$, with the width (b) of both "V" and "U" shapes such that $b \geq 0,2$ mm (see [Figure 2](#) for an explanation of the symbols). Certain scribing tools may also produce a rectangular cross-section, where a , b and c are approximately equal (one example is the "U"-shaped cut variation 2).

NOTE The shape, depth and uniformity of scribe marks resulting from the use of manual scribing tools will also depend on the operator carrying out the scribing procedure. To reduce this operator dependency, and hence variability in subsequent corrosion test results, automatic scribing machines may also be used to introduce scribe marks, provided they produce a scribe mark which penetrates to the substrate. Such machines are able to introduce rectangular shaped scribe marks, where the dimensions a , b and c are approximately equal and each is greater than 0,5 mm.

Dimensions in millimetres

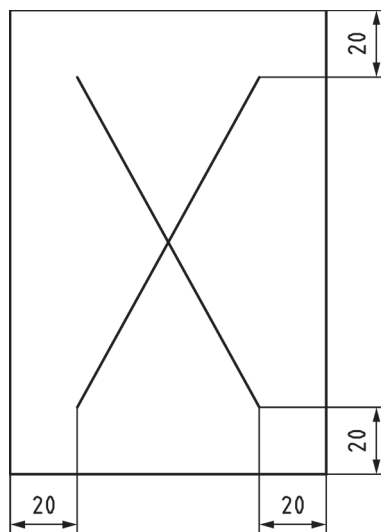

NOTE When evaluating the X-shape scribe in accordance with ISO 4628-8, the section of scribe at the intersection is ignored. Overlapping can happen.

a) X-shape

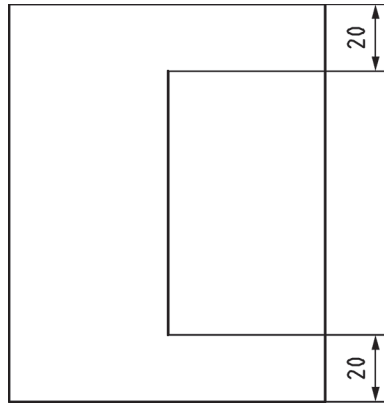

b) Single line

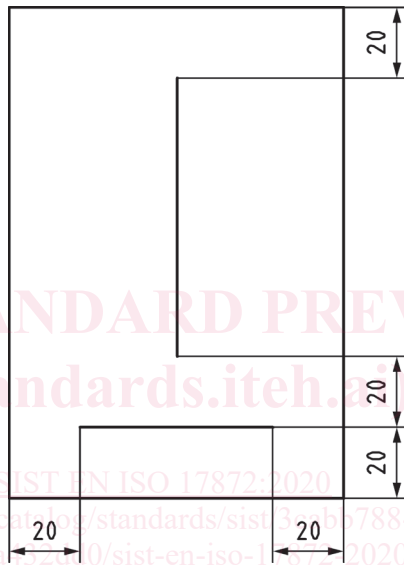

c) T-shape

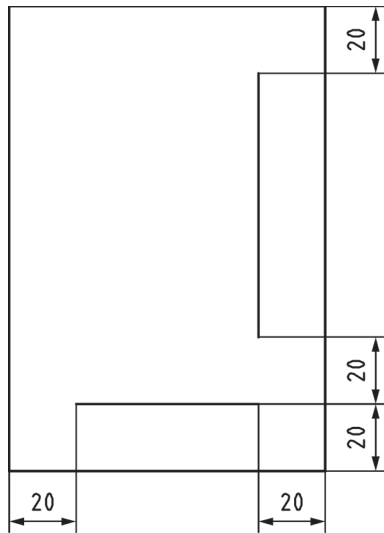

d) L-shape

iTeh STANDARD PREVIEW
(standards.iteh.ai)

SIST EN ISO 17872:2020

<https://standards.iteh.ai/catalog/standards/sist/33cbb788-786b-4670-a864-e4be8a52c0/sist-en-iso-17872-2020>

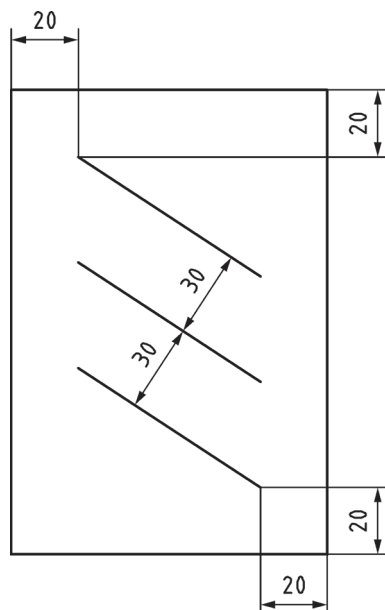

NOTE This shape is used especially for eliminating the influence of the rolling direction of aluminium.

e) Diagonal shape

Figure 1 — Surface shape of scribe marks on coated panels

(standards.iteh.ai)

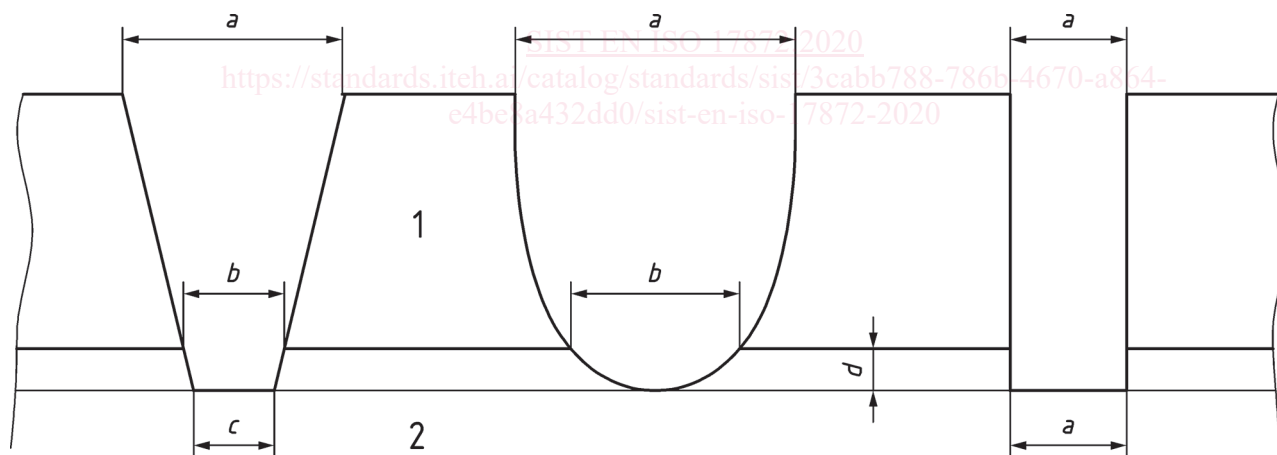

a) "V"-shaped cut

b) "U"-shaped cut variation 1

c) "U"-shaped cut variation 2

Key

- 1 coating
- 2 substrate

- a* width of scribe mark at surface of coating
- b* width of scribe mark at coating/substrate boundary
- c* width of scribe mark at maximum penetration into substrate
- d* penetration of scribe mark into substrate

Figure 2 — Cross-sectional shape of scribe mark through a coating