



**SLOVENSKI STANDARD**  
**oSIST prEN 1824:2019**  
**01-februar-2019**

---

**Materiali za označevanje vozišča - Terenski preskusi**

Road marking materials - Road trials

Straßenmarkierungsmaterialien - Feldprüfungen

Produits de marquage routier - Essais routiers

**Ta slovenski standard je istoveten z: prEN 1824**

<https://standards.iteh.ai/catalog/standards/sist/03ac50b5-938d-4cec-bd33-a1e84b0fe7ac/sist-en-1824-2020>

---

**ICS:**

93.080.20      Materiali za gradnjo cest      Road construction materials

**oSIST prEN 1824:2019**

**en,fr,de**



EUROPEAN STANDARD  
NORME EUROPÉENNE  
EUROPÄISCHE NORM

**DRAFT**  
**prEN 1824**

December 2018

ICS 93.080.20

Will supersede EN 1824:2011

English Version

## Road marking materials - Road trials

Produits de marquage routier - Essais routiers

Straßenmarkierungsmaterialien - Feldprüfungen

This draft European Standard is submitted to CEN members for enquiry. It has been drawn up by the Technical Committee CEN/TC 226.

If this draft becomes a European Standard, CEN members are bound to comply with the CEN/CENELEC Internal Regulations which stipulate the conditions for giving this European Standard the status of a national standard without any alteration.

This draft European Standard was established by CEN in three official versions (English, French, German). A version in any other language made by translation under the responsibility of a CEN member into its own language and notified to the CEN-CENELEC Management Centre has the same status as the official versions.

CEN members are the national standards bodies of Austria, Belgium, Bulgaria, Croatia, Cyprus, Czech Republic, Denmark, Estonia, Finland, Former Yugoslav Republic of Macedonia, France, Germany, Greece, Hungary, Iceland, Ireland, Italy, Latvia, Lithuania, Luxembourg, Malta, Netherlands, Norway, Poland, Portugal, Romania, Serbia, Slovakia, Slovenia, Spain, Sweden, Switzerland, Turkey and United Kingdom.

Recipients of this draft are invited to submit, with their comments, notification of any relevant patent rights of which they are aware and to provide supporting documentation.

**Warning** : This document is not a European Standard. It is distributed for review and comments. It is subject to change without notice and shall not be referred to as a European Standard.



EUROPEAN COMMITTEE FOR STANDARDIZATION  
COMITÉ EUROPÉEN DE NORMALISATION  
EUROPÄISCHES KOMITEE FÜR NORMUNG

**CEN-CENELEC Management Centre: Rue de la Science 23, B-1040 Brussels**

## Contents

	Page
European foreword.....	4
<b>1 Scope .....</b>	<b>5</b>
<b>2 Normative references .....</b>	<b>5</b>
<b>3 Terms and definitions .....</b>	<b>5</b>
<b>4 Test sites and conditions .....</b>	<b>6</b>
4.1 General.....	6
4.2 Test sites characteristics and location .....	6
4.3 Climatic conditions and classes .....	6
4.4 Road surface conditions and classes.....	6
4.5 Roll-over classes.....	7
4.6 Studded tyres.....	8
<b>5 Organization of road trials.....</b>	<b>8</b>
5.1 Duration .....	8
5.2 Transverse and longitudinal application patterns .....	8
5.2.1 General.....	8
5.2.2 Transverse pattern.....	9
5.2.3 Longitudinal pattern.....	9
<b>6 Application of road marking materials.....</b>	<b>10</b>
6.1 General.....	10
6.2 Periods for application.....	11
6.3 Conditions suitable for application .....	11
6.4 Technical specification for application .....	11
6.5 Sampling and measurements.....	12
6.5.1 Sampling.....	12
6.5.2 Measurement of drying time and weather conditions .....	12
6.5.3 Determination of the useful rate(s) of application and the rate(s) of consumption during application .....	12
<b>7 Measurements related to performance .....</b>	<b>12</b>
7.1 General.....	12
7.2 Parameters .....	12
7.3 Measurement areas.....	13
7.3.1 Roll-over classes.....	13
7.3.2 Position .....	13
7.4 Direction of measurements.....	14
7.5 Number of measurements in the measurement area .....	14
7.6 Periodicity of measurements.....	14
<b>8 Individual test report for road marking .....</b>	<b>15</b>
<b>Annex A (normative) Köppen classification.....</b>	<b>16</b>
A.1 Generalities .....	16
A.2 Step 1: Determine whether a climate is arid/semiarid (climate B).....	16
A.3 Step 2: If not a B Climate, identify the climate as A, C, D or E according to temperature data .....	16
A.4 Step 3: After identifying A, Bs, Bw, C, D or E, determine the climate subcategories .....	17

A.4.1	A climates .....	17
A.4.2	B climates .....	17
A.4.3	C or D climates .....	17
A.4.4	E climates.....	17
A.5	Step 4: For C and D climates, determine a third letter .....	17
<b>Annex B</b>	<b>(normative) Measurement of the distribution of wheel passages and the percentage of heavy vehicles.....</b>	<b>18</b>
B.1	Generalities.....	18
B.2	Definitions.....	18
B.3	Principles.....	19
B.4	Wheel counting measurement system.....	19
B.5	Determination of the number of wheel passages .....	20
B.5.1	General .....	20
B.5.2	Determination of the transversal relative wheel passages distribution for one day .....	20
B.5.3	Determination of the number of wheel passages during $\Delta T$ .....	20
B.5.4	Determination of the percentage of heavy vehicles.....	22
B.5.5	Determination of roll over classes .....	22
<b>Annex C</b>	<b>(normative) Determination of the rate of application and the rate of consumption of materials during application.....</b>	<b>23</b>
C.1	General .....	23
C.2	Apparatus .....	23
C.3	Determination of the rate of consumption during application.....	23
C.4	Determination of the useful rate of application .....	24
C.4.1	Drop-on/other material.....	24
C.4.2	Multiple drop-on and other materials .....	24
C.4.3	Determination of the rate of application of the road marking material and its components .....	24
C.5	Expression of results .....	25
<b>Annex D</b>	<b>(normative) Drying time determination .....</b>	<b>26</b>
<b>Annex E</b>	<b>(normative) Meteorological determinations during application .....</b>	<b>27</b>
E.1	General .....	27
E.2	Road surface temperature.....	27
E.3	Temperature and relative humidity of the air .....	27
E.4	Dew point.....	27
E.5	Wind speed.....	28
<b>Annex F</b>	<b>(normative) Removability .....</b>	<b>29</b>
F.1	General .....	29
F.2	Assessment of removability.....	29
<b>Annex G</b>	<b>(normative) Determination of cover index .....</b>	<b>30</b>
G.1	General .....	30
G.2	Apparatus .....	30
G.3	Procedure .....	31
G.4	Evaluation.....	31
<b>Annex H</b>	<b>(informative) Model of test report.....</b>	<b>32</b>
<b>Bibliography</b>	.....	<b>34</b>

## prEN 1824:2018 (E)

### European foreword

This document (prEN 1824:2018) has been prepared by Technical Committee CEN/TC 226 “Road equipment”, the secretariat of which is held by AFNOR.

This document is currently submitted to the CEN Enquiry.

This document will supersede EN 1824:2011.

Annexes A to G of this document are normative and Annex H is informative.

iTeh STANDARD PREVIEW  
(standards.iteh.ai)

SIST EN 1824:2020

<https://standards.iteh.ai/catalog/standards/sist/03ac50b5-938d-4ccc-bd33-a1e84b0fe7ae/sist-en-1824-2020>

## 1 Scope

This document specifies the requirements for conducting road trials for road marking materials intended for use in both permanent and temporary road marking. Details are given for test sites, for the application of road marking materials on the test sites, for the parameters to be measured and the frequency of the measurements and for the presentation of the results in the form of a test report.

## 2 Normative references

The following documents are referred to in the text in such a way that some or all of their content constitutes requirements of this document. For dated references, only the edition cited applies. For undated references, the latest edition of the referenced document (including any amendments) applies.

EN 1436, *Road marking materials - Road marking performance for road users and test methods*

EN 13036-1, *Road and airfield surface characteristics - Test methods – Part 1: Measurement of pavement surface macrotexture depth using a volumetric patch technique*

## 3 Terms and definitions

For the purpose of this document, the following terms and definitions apply.

ISO and IEC maintain terminological databases for use in standardization at the following addresses:

- IEC Electropedia: available at <http://www.electropedia.org/>
- ISO Online browsing platform: available at <http://www.iso.org/obp>

### 3.1

#### **roll-over class**

number of wheels passages over a point of a road surface within a specified period of time

### 3.2

#### **useful rate of application**

quantity, expressed in  $\text{g} \times \text{m}^{-2}$ , of base material and/or drop-on and/or other materials which have adhered to the road surface, when lines are done

### 3.3

#### **rate of consumption during application**

quantity, expressed in  $\text{g} \times \text{m}^{-2}$ , of drop-on or injection materials at the exit of the guns of the application equipment

### 3.4

#### **percentage of heavy vehicles**

ratio between the number of heavy vehicles and the number of all vehicles circulating on the test site

### 3.5

#### **road marking assembly**

base road marking material together with the precise application instructions including the identification of the manufacturer, dosages, types and proportions of additional materials (drop-on or other) needed to build up the applied road marking, every change to which is a new assembly

## prEN 1824:2018 (E)

## 4 Test sites and conditions

### 4.1 General

Test sites shall be arranged at suitable locations in accordance with 4.2 to 4.5. The test results may depend on test field location, climate, road surface and traffic which shall be described according to 4.2 to 4.6.

### 4.2 Test sites characteristics and location

The test site shall be located in an area which belongs to one of the climatic classes defined in 4.3.

The test site shall consist of a field, where the road marking materials are to be applied. The roads used for test sites should be straight and flat and without junctions, substantial obstacles to daylight, sources of frequent dirt (quarries, field exits, etc.) or tracked vehicles.

NOTE It is desirable to have additional areas at the roadsides and/or at both ends in order to allow safe working conditions and convenient operation of application with road marking equipment.

The percentage of heavy vehicles on the test site shall be 5 % to 25 % of all vehicles.

The location of the test site shall be indicated in the test report.

### 4.3 Climatic conditions and classes

Climatic classes (see Table 1) are defined according to the Köppen classification and the use of winter maintenance.

Köppen classification shall be determined according to Annex A.

Winter maintenance is defined by the number of times that snowplough have operated on the test field during the road trials. Winter maintenance is applicable if this number is equal to or greater than 20 and shall be considered only for the Köppen zone Cfb.

**Table 1 — Test field climatic classes**

Climatic Class	Climatic zone according to Köppen
C1	Dfc
	E
C2	Cfb without Winter maintenance
C3	Cfb with Winter maintenance
	Dfb
	Dsb
C4	Csa
	Bsh
	Cfa
	Csb

### 4.4 Road surface conditions and classes

Road trials shall be carried out on asphaltic road surfaces of an age of 1 year or more, which are in good condition and not in need of repair for the duration of the road trials and are not damaged by the presence of wheel tracks, fissures, cracks or similar.



NOTE 1 Road trials on cement concrete surfaces do not give repeatable results because of on-going chemical reactions.

At the commencement of a road trial, a road surface report of the road trial shall be available. The test surface report shall include a general description of the road surface and an account of the texture depth (MTD: mean texture depth), determined in accordance with EN 13036-1.

The MTD shall be measured at several locations on the test field. The number of measurements depends on the test field length. Measurements shall be carried out, at least, at three transversal locations and repeated every 30 m on the test field. The transversal measurements locations are in the centre of the carriageway, near the right and left edge line.

The average mean texture depth is derived from these measurements. The standard deviation shall be less than 0,15 mm.

The averaged texture depth may also be directly determined in accordance with EN ISO 13473-1. Depending to the averaged measured texture depth, the test field roughness is described in term of roughness class according to Table 2.

**Table 2 — Test field roughness classes**

<b>Roughness class</b>	<b>Averaged measured texture depth</b>
RG1	$\leq 0,60$ mm
RG2	$> 0,60$ mm and $\leq 0,90$ mm
RG3	$> 0,90$ mm and $\leq 1,20$ mm
RG4	$> 1,20$ mm

NOTE 2 The texture depth has an influence on the result of road trials, at least for materials applied in thin layers.

#### 4.5 Roll-over classes

The volume of traffic shall be such as to ensure that one or more measurement areas with the desired roll-over class can be selected (see 7.3).

At the termination of a road trial, a traffic report for the duration of the road trial should be made available. The traffic report shall include the roll-over classes according to Table 3, determined on the measurement area(s) in accordance with Annex B.

**Table 3 — Roll-over classes**

Roll-over class	Number of wheel passages
T0	≤ 50 000
T1	Between 50 000 and 60 000
T2	100 000 ± 20 %
P0	≤ 50 000
P1	Between 50 000 and 60 000
P2	100 000 ± 20 %
P3	200 000 ± 20 %
P4	500 000 ± 20 %
P5	1 000 000 ± 20 %
P5.5	1 500 000 ± 10 %
P6	2 000 000 ± 10 %
NOTE The roll-over classes T0, T1 and T2 are for materials intended for temporary road markings, while the roll-over classes P0 to P6 are for materials intended for permanent road markings.	

The traffic report should further include the percentage of heavy vehicles together with an indication of the counting method used.

A vehicle is considered a heavy vehicle if its maximum gross mass is above 7 500 kg.

#### 4.6 Studded tyres

For road trial sites where studded tyres are used, this shall be indicated on the test report. When available, the percentage of vehicles with studded tyres shall be indicated in the report.

NOTE From general experience, such traffic conditions can be relevant to the erosion of road markings.

## 5 Organization of road trials

### 5.1 Duration

A road trial shall include at least one full climatic cycle of one year for materials intended for permanent road marking and up to 6 months for materials intended for temporary road marking. In order to be able to organize road trials on a yearly basis on the same road site, the minimum duration may be reduced to 10 months (provided that the winter period is included in these 10 months). The test reports shall always precise the duration of the road trials.

### 5.2 Transverse and longitudinal application patterns

#### 5.2.1 General

Road marking materials shall be applied in patterns of lines either transverse or longitudinal to the road.

When a long (more than 40 cm) measurement area is necessary, the transverse pattern cannot be used.

When both the transverse and longitudinal patterns are used on the same test site, they shall be used on separate parts of that test site.

### 5.2.2 Transverse pattern

At least three lines shall be applied for each road marking material. The distance between two adjacent lines should be at least 0,35 m and the width at least 0,15 m as shown in Figure 1. The application could be done across one or two lanes.

NOTE Lines of the same material need not be adjacent.

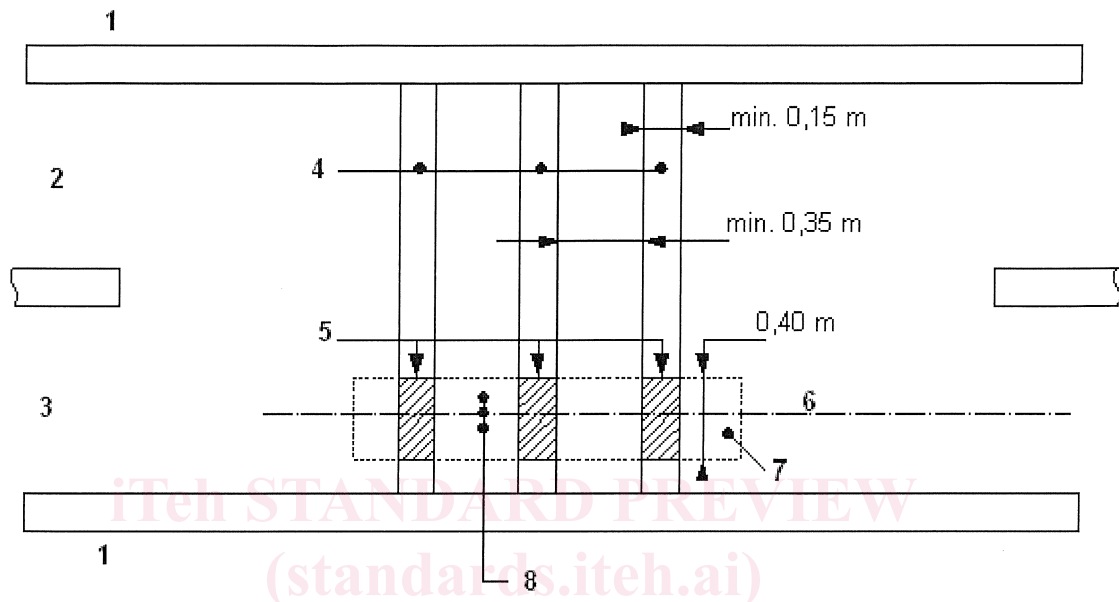

#### Key

1	edge line	5	measurement area
2	lane 2	6	axis of measurement column
3	lane 1	7	measurement column
4	road marking material in test	8	measurement points for determination of the number of wheel passages

**Figure 1 — Example of a transverse pattern showing a measurement column**

### 5.2.3 Longitudinal pattern

Lines are applied in transverse rows and longitudinal columns. For each of the road marking materials there shall be one line in each column containing measurement areas (see 7.3.2.3).

The lines should be at least 0,13 m wide and at least 1 m long as shown in Figure 2. Unmarked space between the lines is a minimum of 0,5 m in the longitudinal direction.

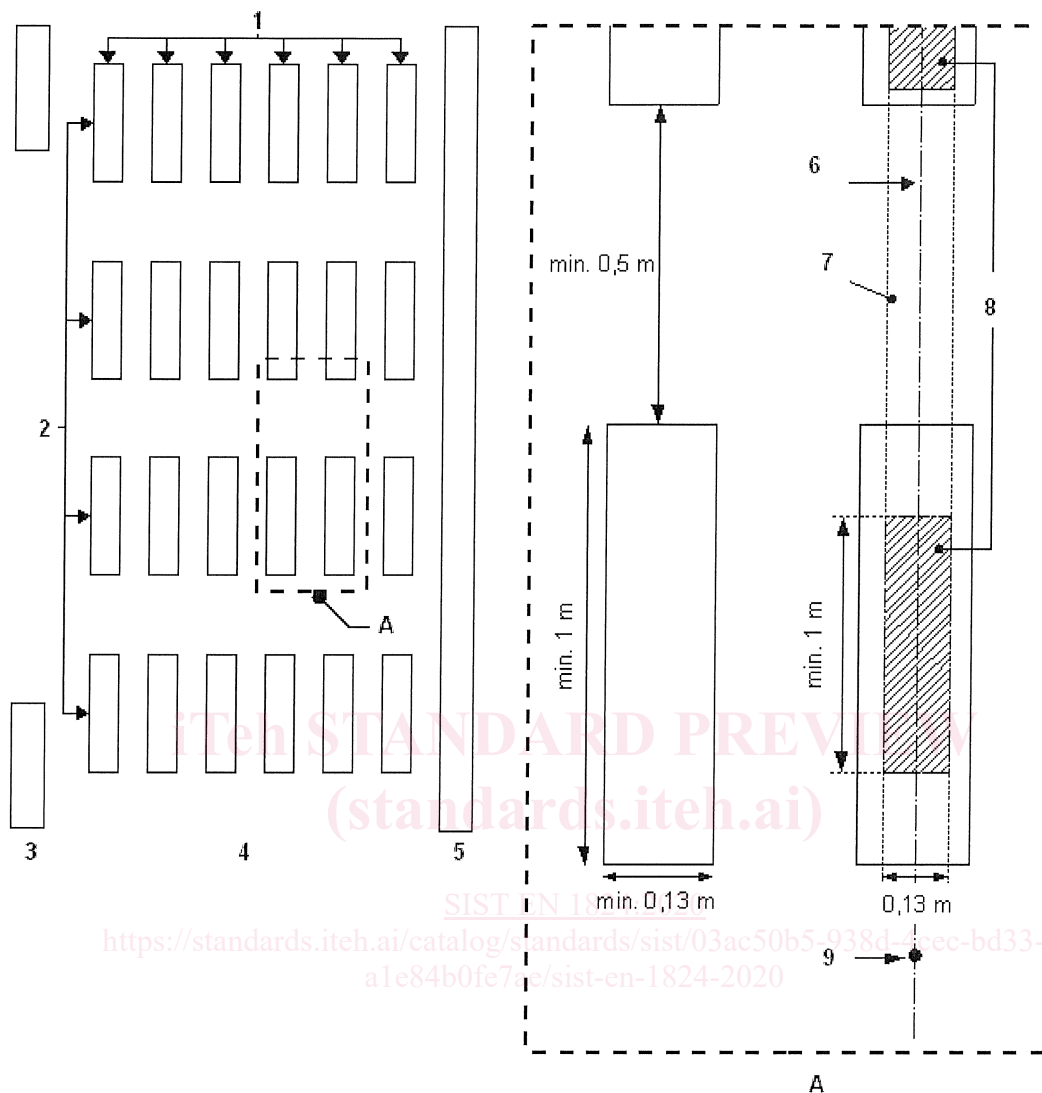
**Key**

- |   |             |   |   |
|---|-------------|---|---|
| 1 | 6 columns   | 6 | axis of measurement column  |
| 2 | 4 rows      | 7 | measurement column  |
| 3 | centre line | 8 | measurement areas   |
| 4 | lane 1      | 9 | measurement point for the determination of the number of wheel passages |
| 5 | edge line   |   |   |

**Figure 2 — Example of a longitudinal pattern showing a measurement column**

## 6 Application of road marking materials

### 6.1 General

In case of longitudinal pattern, the application shall be done in the direction of the traffic.

NOTE The test results depend on various factors related to the application of the road marking materials, i.e. application method, quantities applied, weather conditions, etc.