**Non-magnetic coatings on magnetic
substrates — Measurement of coating
thickness — Magnetic method**

*Revêtement métalliques non magnétiques sur métal de base
magnétique — Mesurage de l'épaisseur du revêtement — Méthode
magnétique*

iTeh STANDARD PREVIEW
(standards.iteh.ai)

[ISO 2178:2016](https://standards.iteh.ai/catalog/standards/sist/eca08554-1165-44be-8b45-c352e1ca63ae/iso-2178-2016)

[https://standards.iteh.ai/catalog/standards/sist/eca08554-1165-44be-8b45-
c352e1ca63ae/iso-2178-2016](https://standards.iteh.ai/catalog/standards/sist/eca08554-1165-44be-8b45-c352e1ca63ae/iso-2178-2016)



iTeh STANDARD PREVIEW
(standards.iteh.ai)

ISO 2178:2016

<https://standards.iteh.ai/catalog/standards/sist/eca08554-1165-44be-8b45-c352e1ca63ae/iso-2178-2016>



COPYRIGHT PROTECTED DOCUMENT

© ISO 2016, Published in Switzerland

All rights reserved. Unless otherwise specified, no part of this publication may be reproduced or utilized otherwise in any form or by any means, electronic or mechanical, including photocopying, or posting on the internet or an intranet, without prior written permission. Permission can be requested from either ISO at the address below or ISO's member body in the country of the requester.

ISO copyright office
Ch. de Blandonnet 8 • CP 401
CH-1214 Vernier, Geneva, Switzerland
Tel. +41 22 749 01 11
Fax +41 22 749 09 47
copyright@iso.org
www.iso.org

Contents

	Page
Foreword	v
1 Scope	1
2 Normative references	1
3 Terms and definitions	1
4 Principle of measurement	2
4.1 Basic principle of all magnetic measurement methods.....	2
4.2 Magnetic pull-off method.....	2
4.3 Magnetic inductive principle.....	3
4.4 Magnetic flux gauge.....	5
5 Factors affecting measurement accuracy	6
5.1 Basic influence of the coating thickness.....	6
5.2 Magnetic properties of the base metal.....	6
5.3 Electrical properties of the coating materials.....	7
5.4 Geometry: base metal thickness.....	7
5.5 Edge effect.....	7
5.6 Geometry: surface curvature.....	7
5.7 Surface roughness.....	8
5.8 Cleanliness: lift-off effect.....	8
5.9 Probe pressure.....	8
5.10 Probe tilt.....	8
5.11 Temperature effects.....	9
5.12 External electromagnetic fields.....	9
6 Calibration and adjustment of the instrument	9
6.1 General.....	9
6.2 Thickness reference standards.....	9
6.3 Methods of adjustment.....	10
7 Measurement procedure and evaluation	10
7.1 General.....	10
7.2 Number of measurements and evaluation.....	11
8 Uncertainty of the results	11
8.1 General remarks.....	11
8.2 Uncertainty of the calibration of the instrument.....	12
8.3 Stochastic errors.....	13
8.4 Uncertainties caused by factors summarized in Clause 5	13
8.5 Combined uncertainty, expanded uncertainty and final result.....	14
9 Precision	14
9.1 General.....	14
9.2 Repeatability (r).....	14
9.3 Reproducibility limit (R).....	15
10 Test report	15
Annex A (informative) Basic principle of all measurement methods	17
Annex B (informative) Basic performance requirements for coating thickness gauges which are based on the magnetic method described in this International Standard	19
Annex C (informative) Examples of experimental estimation of factors affecting the measurement	21
Annex D (informative) Example of uncertainty estimation (see Clause 8)	26
Annex E (informative) Basics of the determination of the uncertainty of a measurement of the used measurement method corresponding to ISO/IEC Guide 98-3	29

Annex F (informative) Table of the student factor	31
Annex G (informative) Details on precision	32
Bibliography	37

iTeh STANDARD PREVIEW
(standards.iteh.ai)

[ISO 2178:2016](https://standards.iteh.ai/catalog/standards/sist/e1ca63ae/iso-2178-2016)

<https://standards.iteh.ai/catalog/standards/sist/e1ca63ae/iso-2178-2016>

Foreword

ISO (the International Organization for Standardization) is a worldwide federation of national standards bodies (ISO member bodies). The work of preparing International Standards is normally carried out through ISO technical committees. Each member body interested in a subject for which a technical committee has been established has the right to be represented on that committee. International organizations, governmental and non-governmental, in liaison with ISO, also take part in the work. ISO collaborates closely with the International Electrotechnical Commission (IEC) on all matters of electrotechnical standardization.

The procedures used to develop this document and those intended for its further maintenance are described in the ISO/IEC Directives, Part 1. In particular the different approval criteria needed for the different types of ISO documents should be noted. This document was drafted in accordance with the editorial rules of the ISO/IEC Directives, Part 2 (see www.iso.org/directives).

Attention is drawn to the possibility that some of the elements of this document may be the subject of patent rights. ISO shall not be held responsible for identifying any or all such patent rights. Details of any patent rights identified during the development of the document will be in the Introduction and/or on the ISO list of patent declarations received (see www.iso.org/patents).

Any trade name used in this document is information given for the convenience of users and does not constitute an endorsement.

For an explanation on the meaning of ISO specific terms and expressions related to conformity assessment, as well as information about ISO's adherence to the WTO principles in the Technical Barriers to Trade (TBT) see the following URL: [Foreword - Supplementary information](#)

The committee responsible for this document is ISO/TC 107, *Metallic and other inorganic coatings*.

This third edition cancels and replaces the second edition (ISO 2178:1982), which has been technically revised.

<https://standards.iteh.ai/catalog/standards/sist/eca08554-1165-44be-8b45-c352e1ca63ae/iso-2178-2016>

iTeh STANDARD PREVIEW
(standards.iteh.ai)

ISO 2178:2016

<https://standards.iteh.ai/catalog/standards/sist/eca08554-1165-44be-8b45-c352e1ca63ae/iso-2178-2016>

Non-magnetic coatings on magnetic substrates — Measurement of coating thickness — Magnetic method

1 Scope

This International Standard specifies a method for non-destructive measurements of the thickness of non-magnetizable coatings on magnetizable base metals.

The measurements are tactile and non-destructive on typical coatings. The probe or an instrument with integrated probe is placed directly on the coating to be measured. The coating thickness is displayed on the instrument.

In this International Standard the term “coating” is used for material such as, for example, paints and varnishes, electroplated coatings, enamel coatings, plastic coatings, powder coatings, claddings.

NOTE This method can also be applied to the measurement of magnetizable coatings on non-magnetizable base metals or other materials (see ISO 2361).

2 Normative references

The following documents, in whole or in part, are normatively referenced in this document. For dated references, only the edition cited applies. For undated references, the latest edition of the referenced document (including any amendments) applies.

ISO 2064, *Metallic and other inorganic coatings — Definitions and conventions concerning the measurement of thickness* [https://standards.iteh.ai/catalog/standards/sist/eca08554-1165-44be-8b45-](https://standards.iteh.ai/catalog/standards/sist/eca08554-1165-44be-8b45-c352e1ca63ae/iso-2178-2016)

[c352e1ca63ae/iso-2178-2016](https://standards.iteh.ai/catalog/standards/sist/eca08554-1165-44be-8b45-c352e1ca63ae/iso-2178-2016)

ISO 4618, *Paints and varnishes — Terms and definitions*

ISO 5725-1:1994, *Accuracy (trueness and precision) of measurement methods and results — Part 1: General principles and definitions*

ISO/IEC Guide 98-3, *Uncertainty of measurement — Part 3: Guide to the expression of uncertainty in measurement (GUM:1995)*

3 Terms and definitions

For the purposes of this document, the terms and definitions given in ISO 2064 and ISO 4618 and the following apply.

3.1

adjustment of a measuring system

set of operations carried out on a measuring system so that it provides prescribed indications corresponding to given values of a quantity to be measured

Note 1 to entry: Adjustment of a measuring system can include zero adjustment, offset adjustment, and span adjustment (sometimes called gain adjustment).

Note 2 to entry: Adjustment of a measuring system should not be confused with calibration, which is a prerequisite for adjustment.

Note 3 to entry: After an adjustment of a measuring system, the measuring system shall usually be recalibrated.

Note 4 to entry: Colloquially the term “calibration” is frequently but falsely used instead of the term “adjustment”. In the same way, the terms “verification” and “checking” are often used instead of the correct term “calibration”.

[SOURCE: ISO/IEC Guide 99:2007, 3.11 (also known as “VIM”), modified – Note 4 to entry has been added.]

3.2 calibration

operation that, under specified conditions, in a first step, establishes a relation between the quantity values with measurement uncertainties provided by measurement standards and corresponding indications with associated measurement uncertainties and, in a second step, uses this information to establish a relation to obtain a measurement result from indication

Note 1 to entry: A calibration may be expressed by a statement, calibration function, calibration diagram, calibration curve, or calibration table. In some cases, it may consist of an additive or multiplicative correction of the indication with associated measurement uncertainty.

Note 2 to entry: Calibration should not be confused with adjustment of a measuring system, often mistakenly called “self-calibration”, nor with verification of calibration.

Note 3 to entry: Often, the first step alone in the above definition is perceived as being calibration.

[SOURCE: ISO/IEC Guide 99:2007, 2.39 (also known as “VIM”)]

4 Principle of measurement

4.1 Basic principle of all magnetic measurement methods

The magnetic flux density close to a magnetic field source (permanent magnet or electromagnet) depends on the distance to a magnetizable base metal. This phenomenon is used to determine the thickness of a non-magnetic coating applied to the base metal.

NOTE 1 [Annex A](#) describes the physical background of this effect in more detail.

All the methods covered by this International Standard evaluate the magnetic flux density to determine the thickness of the coating. The strength of the magnetic flux density is converted into corresponding electrical currents, electrical voltages or mechanical forces depending on the method used. The values are either pre-processed by digital means or are directly displayed on a usefully scaled gauge.

NOTE 2 The methods described in [4.3](#) and [4.4](#) can also be combined in one and the same probe with another method, e.g. with the eddy current method according to ISO 2360 or ISO 21968.

[Annex B](#) describes the basic performance requirements for coating thickness gauges based on the magnetic method described in this International Standard.

4.2 Magnetic pull-off method

The magnetic flux density of a permanent magnet and thus the attraction force between a permanent magnet and a magnetizable base metal decreases with increasing distance. In this way, the attraction force is a direct measure for the coating thickness of interest.

Instruments working with the magnetic pull-off method consist of at least three units:

- a permanent magnet;
- a pull-off device with continuously increasing pull-off force;
- a display or scale for the coating thickness, which is calculated from the pull-off force.

The pull-off force can be generated by different types of springs or an electromagnetic device.

Some instruments are able to compensate the influence of gravity and allow measurements in all positions.

All other instruments may only be used in the position specified by the manufacturer.

The location of measurement shall be clean and free from liquid or pasty coatings. The permanent magnet shall be free from particles.

Electrostatic charging can cause additional forces on the permanent magnet or the measuring system and is therefore to be avoided or shall be discharged before the measurement.

[Figure 1](#) shows a magnetic pull-off gauge.

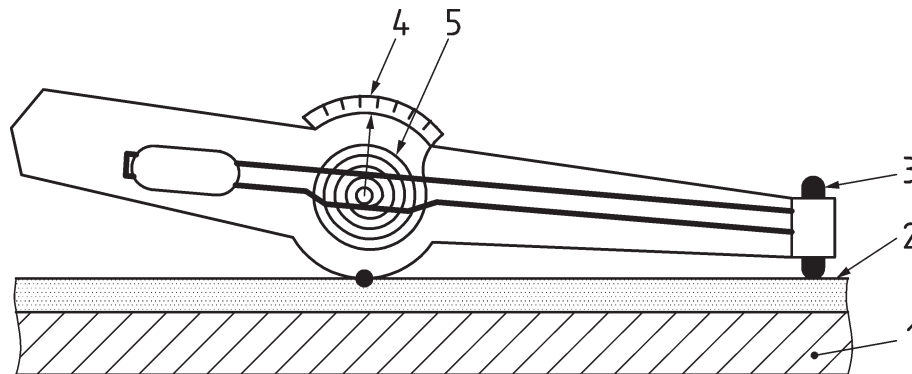

Key

- 1 base metal
- 2 coating
- 3 magnet
- 4 scale
- 5 spring

iTeh STANDARD PREVIEW
(standards.iteh.ai)

ISO 2178:2016
Figure 1 — Magnetic pull-off gauge
<https://standards.iteh.ai/catalog/standards/sist/cca08554-1165-446e-8b45-c352e1ca63ae/iso-2178-2016>

4.3 Magnetic inductive principle

The electrical inductivity of a coil changes when an iron core is inserted into the coil or when an iron object, e.g. a plate, approaches the coil. Therefore, the electrical inductivity can be used as a measure of the distance between the coil and a ferromagnetic substrate or as a measure of the coating thickness, if the coil is placed onto a coated magnetizable base metal.

There are many different electronic methods to evaluate changes of the electrical inductivity or the reaction of a coil system to a ferromagnetic substrate. Magnetic induction probes for thickness measurements of coatings on magnetizable materials can consist of one or more coils. Most often two coils are used (see [Figure 2](#)): the first (primary coil) to generate a low frequency alternating magnetic field and the second (secondary coil) to measure the resulting induced voltage U . If the probe is placed on a coated magnetizable material ($\mu_r > 1$) the magnetic flux density (see [Annex A](#)) and the induced voltage of the secondary coil vary as a function of the coating thickness. The function between the induced voltage and the coating thickness is nonlinear and depends on the permeability μ_r of the base metal. It is usually determined by a calibration. Calibration curves that assign a coating thickness to the induced voltages can be stored in the gauge.

Different designs and geometries of these kind of probes are used. Very often both coils are employed together with a highly magnetizable core in order to increase the sensitivity of the probes and to concentrate the field. In this way, both the coating area, which contributes to the thickness measurement, and the influence of the geometry of the coated component are reduced (see [5.5](#) and [5.6](#)).

On the contrary, a two pole probe (see [Figure 3](#)) has a wide and open field distribution. The two-pole probe has area integrating properties, while a one-pole probe measures locally.

Usually the frequency of the generated field is below the kilohertz range, which avoids eddy current generation if the coatings are conductive. Therefore, both conductive and nonconductive coatings can be measured by means of this principle.

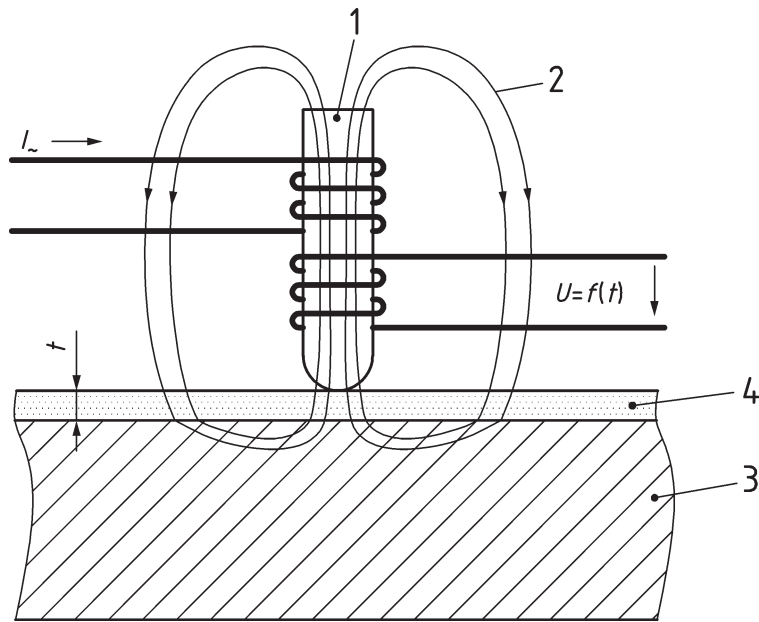

Key

- 1 iron core of the probe
- 2 low frequency alternating magnetic field
- 3 steel/iron substrate
- 4 coating

iTeh STANDARD PREVIEW
 (standards.iteh.ai)
 ISO 2178:2016
<https://standards.iteh.ai/catalog/standards/sist/eca08554-1165-44be-8b45-c352e1ca63ae/iso-2178-2016>

Figure 2 — Schematic of the magnetic induction principle

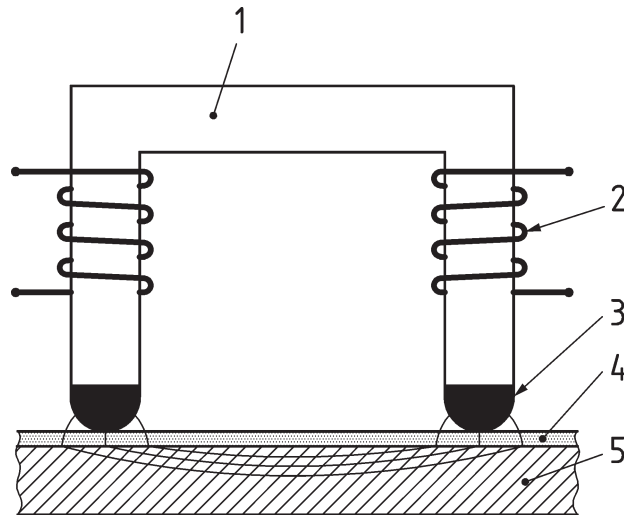
**Key**

1	iron core of the probe	4	coating
2	coil system	5	base metal
3	probe tip		

Figure 3 — Schematic of a two pole probe
 iTeh STANDARD PREVIEW
 (standards.iteh.ai)

4.4 Magnetic flux gauge

The magnetic flux density close to a magnet depends on the magnetic properties of the substances in the magnetic field. The magnetic flux density decreases if the fraction of non-magnetizable substances increases relative to magnetizable substances. This fact is used in magnetic flux gauges (see [Figure 4](#)). The coating (4) is non-magnetizable; the base metal (3) is magnetizable. A magnet (1) creates a magnetic field. Its field lines pass through both the coating and the base metal. A magnetic flux detector (5) placed close to the magnet outputs electrical signals, which depends on the coating thickness.

NOTE 1 Magnetic flux detectors are Hall-sensors or magneto resistive sensors.

NOTE 2 The magnet can be a permanent magnet or an electromagnet.

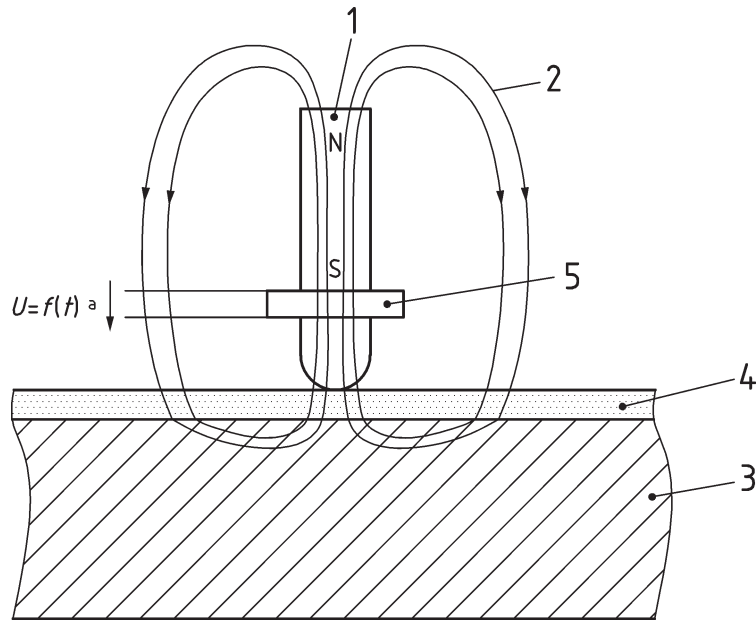

Key

- | | | | |
|---|--|-----|--------------------|
| 1 | permanent magnet | U | output voltage |
| 2 | static magnetic field | a | measurement signal |
| 3 | base metal | | |
| 4 | coating | | |
| 5 | Hall element as magnetic flux detector | | |

iTeh STANDARD PREVIEW
(standards.iteh.ai)

ISO 2178:2016
<https://standards.iteh.org/standards/iso/2178/2016>
Figure 4 — Flux gauge using a Hall probe
<https://standards.iteh.org/standards/iso/2178/2016>

The electric signals of the flux detector are further processed by electronic means. The function between flux detector output and the coating thickness is nonlinear and depends on the permeability μ_r of the base metal. It is usually determined by calibration. Calibration curves that assign a coating thickness to the electric detector output can be stored in the gauge.

5 Factors affecting measurement accuracy

5.1 Basic influence of the coating thickness

The sensitivity of a probe, i.e. the measurement effect, decreases with increasing thickness within the measurement range of the probe. In the lower measurement range this measurement uncertainty (in absolute terms) is constant, independent of the coating thickness. The absolute value of this uncertainty depends on the properties of the probe system and the used sample materials, e.g. the homogeneity of the base metal permeability, the base metal roughness and the sample surface roughness. In the upper measurement range of the probe the uncertainty becomes relative to the thickness and is approximately a constant fraction of that thickness.

5.2 Magnetic properties of the base metal

The permeability of the base metal causes the measurement effect of this method.

The relationship between coating thickness and the measured value depends strongly on the permeability of the base metal. Consequently, calibration procedures and measurements shall be made on the same material. Different materials with different permeabilities can cause more or fewer

thickness errors as well as local fluctuations of the permeability or variations between different samples.

Residual magnetism of the base material can also affect the measurements considerably, especially when static magnetic fields are used (see 4.2 for magnetic pull-off force or 4.4 for magnetic flux gauge).

The base metal can be magnetized by repeated measurements on the same location if a measurement method with a static magnetic field is used (see 4.2 for magnetic pull-off force or 4.4 for magnetic flux gauge). This may lead to errors in the thickness readings.

NOTE Examples of the initial permeability of typical steel used is in the range of 100 to 300.

5.3 Electrical properties of the coating materials

Coating thickness measurements can be affected if the probe is operated with an alternating magnetic field due to eddy currents (see 4.3 for magnetic inductive principle or 4.4 for magnetic flux gauge). These induced eddy currents can counteract the measurement effect of the magnetic method. The induced eddy current density increases with increasing conductivity and frequency.

NOTE Usually instruments using measurement methods 4.3 or 4.4 work within a frequency range below 1 kHz. Therefore, induced eddy currents affecting measurement results are only effective for thick coatings (thickness above 1 mm) with a high conductivity, e.g. copper.

5.4 Geometry: base metal thickness

If the base metal thickness is too small, the interaction of the magnetic field with the base metal is reduced. This influence can only be disregarded above a certain critical minimum base metal thickness.

Therefore, the thickness of the base metal should always be higher than this critical minimum base metal thickness. An adjustment of the instrument can compensate for errors caused by a too low base metal thickness. However, any variation in thickness of the base metal can cause increased uncertainty and errors.

The critical minimum base metal thickness depends on both the probe system (field strength, geometry) and the magnetic properties of the base metal. Its value should be determined experimentally, unless otherwise specified by the manufacturer.

NOTE A simple experiment to estimate the critical minimum base metal thickness is described in C.2.

5.5 Edge effect

The expansion of the magnetic field is obstructed by geometric limitations of the base metal (e.g. edges, drills and other). Therefore, measurements made too near to an edge or corner cannot be valid unless the instrument has been specifically adjusted for such measurements. The necessary distance in order to avoid an impact of the edge effect depends on the probe system (field distribution).

NOTE A simple experiment to estimate the edge effect is described in C.3.

5.6 Geometry: surface curvature

The propagation of the magnetic field is affected by the base metal surface curvature. This influence becomes more pronounced with decreasing radius of the curvature and decreasing coating thickness. In order to minimize this influence an adjustment should be performed on a base metal with the same geometry.

The influence of surface curvature depends considerably on the probe geometry and can be reduced by reducing the sensitive area of the probe. Probes with very small sensitive areas are often called microprobes.